



2020 Catalog

F400

Air Insulated Switchgear up to 36 / 40.5 kV
Floor rolling circuit breaker

Medium Voltage Distribution

General contents

F400

PM108501



Overview

Overview of field of applications, service continuity, digital solutions, quality and services.

7

Range description

Overview of range and standards.

21

Function/module description

Functions descriptions, characteristics, and performances.

27

Components and accessories

Circuit breakers, current and voltage transformers, protection relays, internal arc protection, thermal and environmental sensors.

39

Installation and connection

Installation details, implementation examples, standard and optional features for equipment ordering.

67

Your concerns

Safety



Reliability



Simplicity

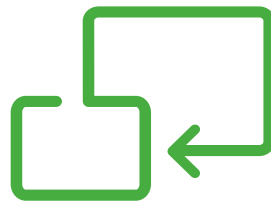

Efficiency



Our solutions

Safety

- F400 cubicles are classified to withstand internal arcing as AFLR up to 31.5 kA/1s
- Arc protection unit available to increase the protection in the event of internal arcing. This unit can detect any arc flash in the installation and trip the feeding breaker
- F400 cubicles are classified as LSC2B - earthed metallic partitions between MV compartments increasing safety through protection against electrical, mechanical and thermal effects of a fault (insulation of each compartment)
- All operations (open, close) of circuit breaker and earthing switch can be carried out from remote, avoiding standing in front of the cubicles
- Mechanical and electrical interlocks embedded to enhance operator safety
- Single "Anti-reflex" handle for all operations to enhance operator safety
- Voltage Presence Indicator System located on the front panel checking energy presence before operating earthing switch to enhance operator safety
- Designed for seismic environment, certified for 1.25g (8 on Richter scale) as per IEC standards

Reliability

- F400 is fully compliant with metal enclosed switchgear IEC standards
- It is designed for 30 years life time with respect of installation, operations and environmental conditions
- Clear guided operation with ergonomic operator interface implemented to avoid any misuse
- Manufacturing & Testing according to ISO 9001:2008 quality standard
- Design integrating a trolley for the withdrawable circuit breaker insuring a perfect connection and match to the busbars

Simplicity

- Two switching technologies - Same operations for two breaking technologies, vacuum and SF6. Fully interchangeability in between SF6 and vacuum breaker.
- The breakers and earthing switches can be operated from the front/nearby or remote control
- Faster and ergonomic installation – busbar at the bottom to avoid heavy lifts, higher cable connection level (>1m), up to 4 runs of cables per phase possible in standard design
- Simplified operations thanks to 'no tool can be forgotten on F400 ring type busbars', single handle for all operations, floor rolling design to avoid external trolley
- Easy maintenance and replacement on VT – rotative design
- Direct access to all documents (catalog, user guide,..) of cubicles, breakers, relays through QR codes on the front door of each cubicle

Efficiency

- Compact design with reduced footprint: the F400 design allows various functions to be accommodated in very space optimized cubicles: from 900 mm width to 2 335 mm height with voltage transformers (2 255 mm height without voltage transformers), and a managed depth of 2 724 mm*, F400 will fit in a variety of environments (* 2 724 mm available with forced at 2500 A)
- Operating costs savings: thanks to its remote operations management, human intervention is reduced
- Maintenance costs savings: thanks to new connected F400 detecting hot-spots at early stage, preventing from downtime and providing the right maintenance activity at the right time. Now, it enables more to increase service continuity

Overview

Field of application	8
Continuity of service	10
EcoStruxure™ ready solutions	11
Quality assurance - environment	18
Schneider Electric Services	19

Field of application

Schneider Electric has developed protection, monitoring and control solutions specifically dedicated to Medium Voltage networks for over 40 years. F400 switchgear has been specifically designed on the basis of that extensive experience. It also incorporates some new solutions, helping to ensure the continuity of service and operators' safety.

High-performance breaking devices

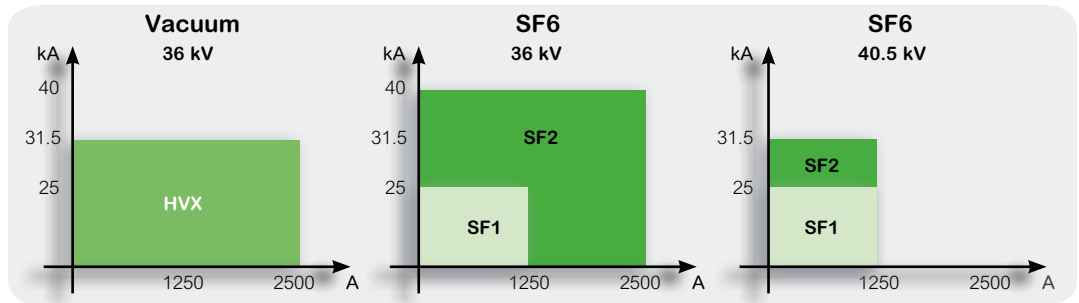

A comprehensive solution

F400 switchgear is fully compatible with

- PowerMeter and Circuit Monitor metering units
- GemControl management system specifically dedicated to control & monitoring functions.
- Easergy series multi-function protection relays
 - Protection.
 - Measurements and diagnosis.
 - Local & remote indication and operation

F400 switchboards can easily be integrated into monitoring and control system.

Enclosures able to withstand internal arcing

- Internal Arc Classification: AFLR
- Arc protection unit available, able to detect any arc flash in the installation and to trip the feeding breaker

Space savings

F400 design allows various functions to be accommodated in space-optimized cubicles: from 900 mm width to 2335mm height, with voltage transformers (2 255 mm without voltage transformers), and a managed depth of 2 724 mm, F400 will fit in variety of environments.

More than **20 000** cubicles of switchgear installed world-wide.

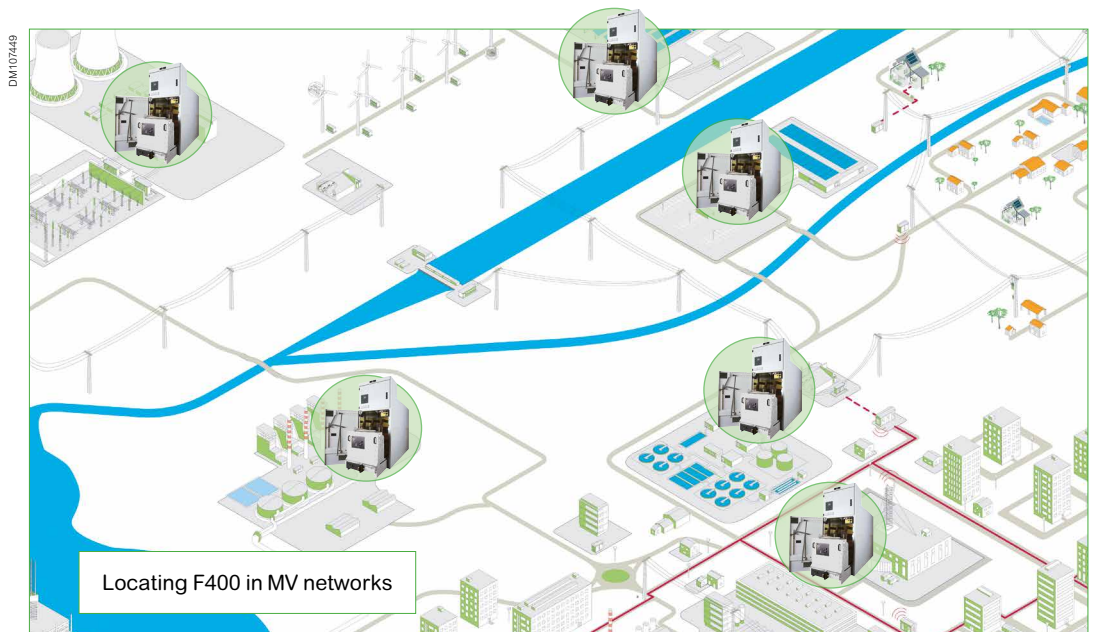

PM106522



F400 is suitable for all electrical power distribution requirements from 1 to 36/40.5 kV

F400 metal-enclosed switchgear consists of withdrawable units designed for indoor installation. F400 is designed for the MV section of HV/MV substations and high-power MV/MV substations.

F400 offers you:

- Pre-engineered solutions that can be adapted to your specific requirements
- Significantly reduced maintenance
- Local support centres throughout the world.

F400 gives you the advantages of:

- Continuity of service for your networks
- Enhanced safety for your staff and operations
- Optimized investment throughout the life of your installation
- The possibility of incorporating your medium voltage switchboard in a monitoring and control system.

PM106286



Applications

Power supply companies

- HV/MV substation
- MV/MV substation
- MV/LV substation
- Power generation

Industry

- Oil & gas industry
- Chemical industry
- Automotive industry
- Mining / Mineral / Metal industry

Infrastructures

- Airports
- Ports
- Water plants

PM106287



PM106862



Specific applications

Seismic areas

F400 has seismic withstand as 1.25 g which is considered for the regions of seismicity up to magnitude 8 as per Richter scale. Seismic certification for 1.25 g is available as per following standards:

- IEEE 693 (2018)
- IEC 60068-3-3
- IEC 62271-210
- IEC 60068-2-6



F400 is solidly based on extensive experience acquired throughout the world and provides your networks with a high level of dependability and safety.

F400 incorporates a host of innovative solutions designed around proven techniques: high-performance switchgear, digital protection, monitoring and control systems, enclosures capable of withstanding internal arcing.

From the design stage, F400 allows for three key user requirements:

Reliability

- Type testing was carried out for each performance level in the F400 range
- The design, manufacturing and testing of F400 was carried out according to the ISO 9001:2008 quality standard
- Three-dimensional computer modelling techniques were used to study electrical fields



Simplicity

- Faster and ergonomic installation – busbar at the bottom to avoid heavy lifts, higher cable connection level (>1 m), up to 4 runs of cables per phase possible in standard design
- A user interface which is easily understood by everybody.
- Interlocks and padlocks helping to prevent operator errors
- Easergy series protection units enabling on-site information retrieval without any additional devices
- Maintenance limited to simple, routine operating checks and cleaning and greasing every 5 to 10 years
- Easy installation due to identical civil engineering dimensions for all cubicles



Safety

- All operations are performed from the front (operation of rotary type voltage transformer and installation of medium voltage cable connections from the rear side)
- Racking in or out is only possible with the door closed
- Voltage Presence Indicators (VPIS) are situated on the front door of each functional unit
- The earthing switch has making capacity
- “Anti-reflex” handles are used for all operations
- Internal arc withstand developed for all functional units, achieving AFLR protection class in accordance with IEC/EN 62271-200.

EcoStruxure™ ready solutions

What is EcoStruxure™?

500 000

EcoStruxure™ has been deployed in almost 500 000 sites with the support of 20 000+ developers, 650 000 service providers and partners, 3 000 utilities, and connects over 2 million assets under management.

EcoStruxure™ ready



Efficient asset management

Greater efficiency with **predictive** maintenance helping to reduce downtime



24/7 connectivity

Real-time data **everywhere anytime** to make better-informed decisions



Increased safety

Proven design and experience combined with fast **embedded arc detection** to enhance people's safety and equipment's protection

EcoStruxure™ is our open, interoperable, IoT-enabled system architecture and platform. EcoStruxure delivers enhanced value around **safety, reliability, efficiency, sustainability, and connectivity** for our customers. EcoStruxure leverages advancements in IoT, mobility, sensing, cloud, analytics, and cybersecurity to deliver Innovation at Every Level. This includes Connected Products, Edge Control, and Apps, Analytics & Services which are supported by Customer Lifecycle Software.

Turn data into action

EcoStruxure™ architecture lets customers maximize the value of data.

Specifically, it helps them:

- Translate data into actionable intelligence and better business decisions
- Take informed decisions to secure uptime and operational efficiency thanks to real-time control platforms
- Gain visibility to their electrical distribution by measuring, collecting, aggregating, and communicating data

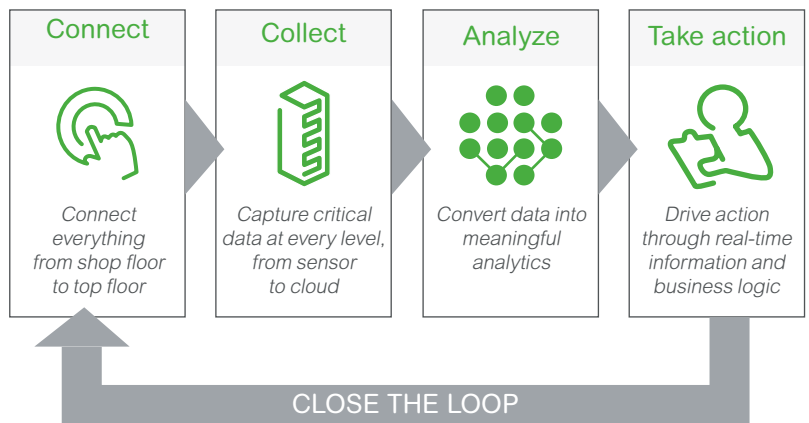

EcoStruxure™ architecture

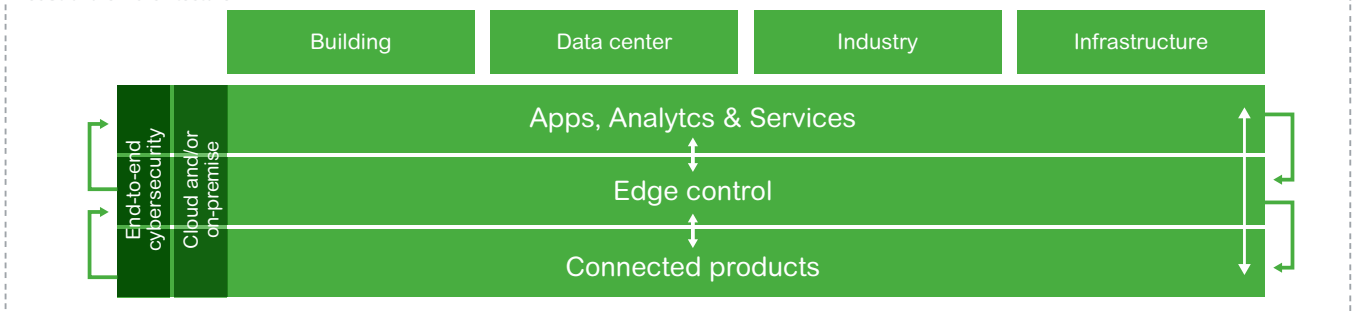

EcoStruxure Power

EcoStruxure Building

EcoStruxure IT

EcoStruxure Machine

EcoStruxure Plant

EcoStruxure Grid

EcoStruxure™ ready solutions

EcoStruxure™ Grid

Enable nearby control, ensure safety and uptime

All the Schneider Electric protection, metering and control devices can be connected to our Substation monitoring device.

The HMI can be installed anywhere within the substation to allow local control and monitoring, independent of any external systems.

The monitoring information and control functions can be scaled to the needs of each customer.

Optionally, the Magelis control and monitoring functions can be mirrored on a tablet through Wifi connection thanks to our Vijeo Design Air application. The technician can operate remotely the switchgear, while keeping visual contact with it.

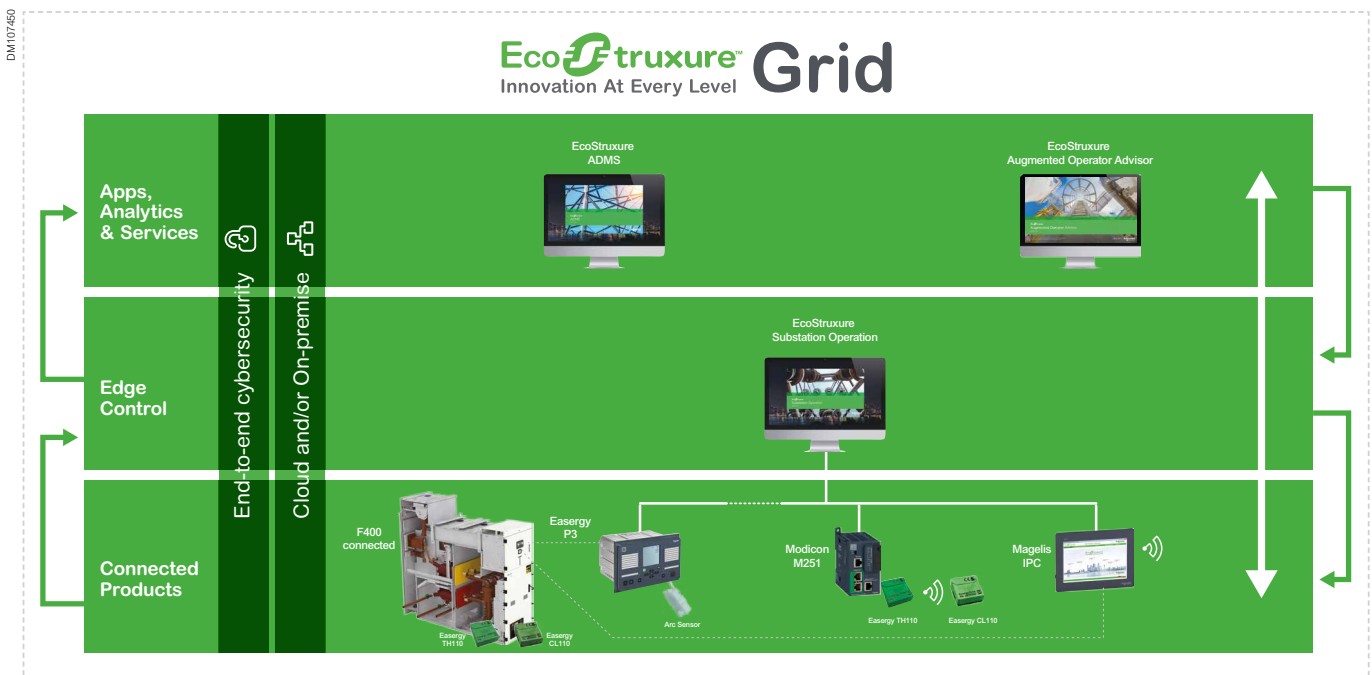
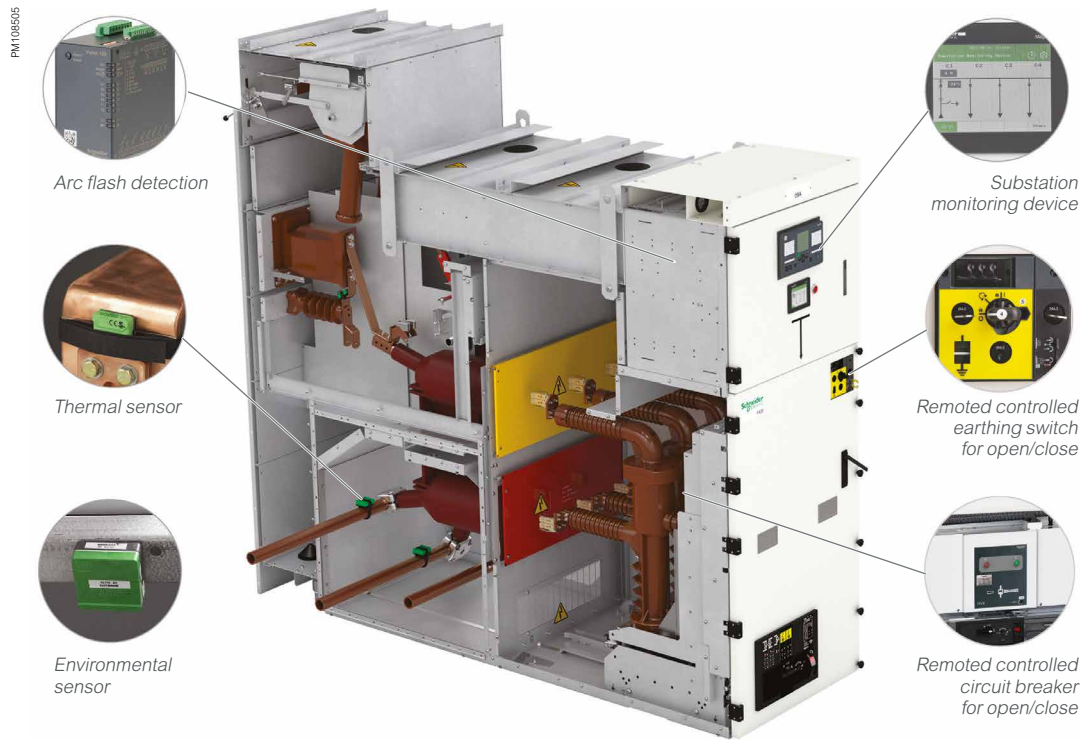

EcoStruxure™ ready solutions

EcoStruxure™ Power

EcoStruxure™ Power is one of the six domains of EcoStruxure™, our IoT-enabled architecture and platform.

EcoStruxure™ Power plays a key role in all four End-Markets (Building, Data Center, Industry and Infrastructure). This involves bringing the world of electrical distribution to those End-Markets.

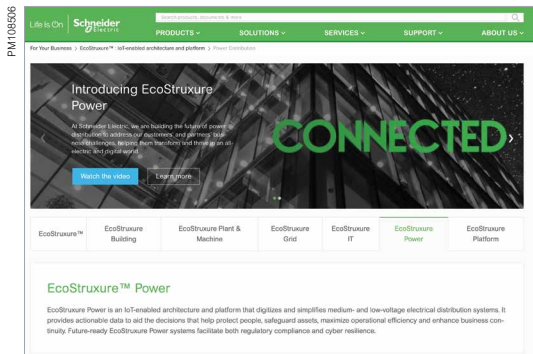
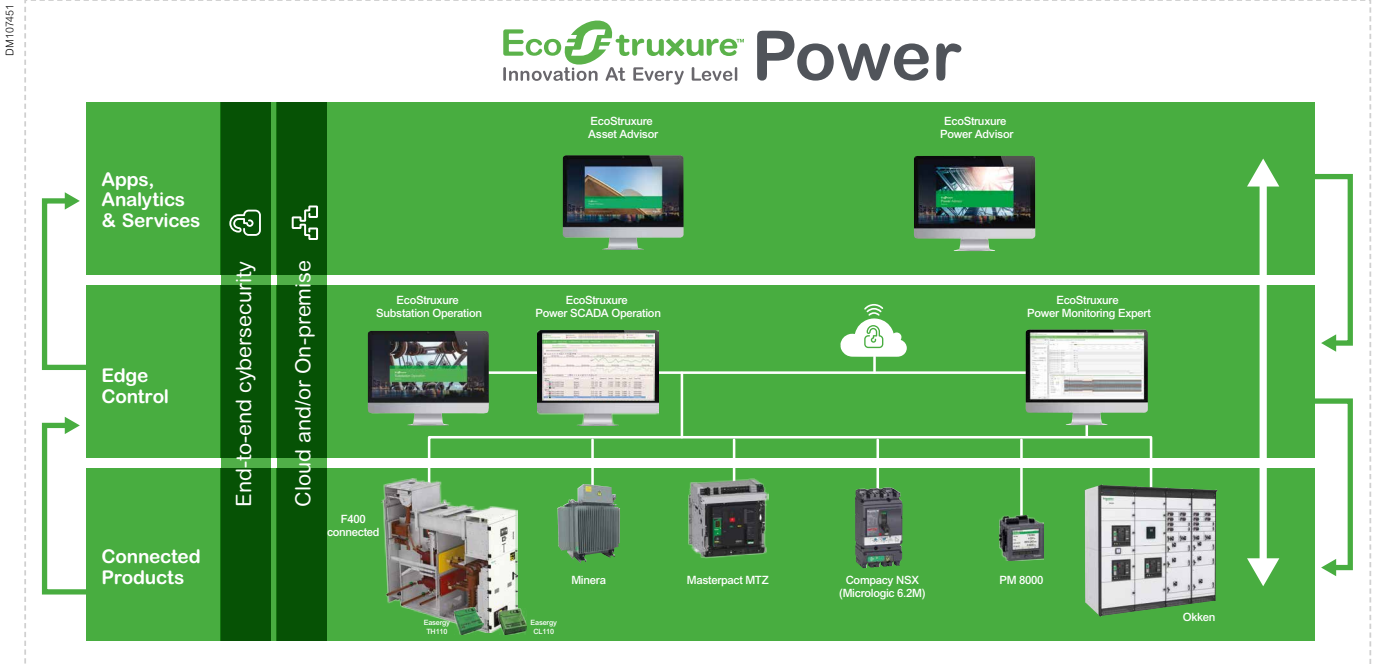

More about
EcoStruxure™ Power
se.com/ww/ecostruxure-power



EcoStruxure™ Power digitizes and simplifies low and medium voltage electrical distribution systems. It provides essential data to aid the decisions that help protect people, safeguard assets, maximize operational efficiency and business continuity, and maintain regulatory compliance.

EcoStruxure™ Power is an open architecture and platform designed with the intention of making it easy to add, upgrade, and swap components. The world is full of electrical distribution systems in various stages of maturity, produced by a variety of manufacturers. Interoperability with EcoStruxure™ Power is essential to making these power distributions systems future ready. The added benefit of a holistic Schneider Electric system is plug-and-play connectivity to achieve faster and lower risk integration and commissioning.

EcoStruxure™ Power architectures are cost-optimized to deploy, using only the right technology to deliver the desired business outcomes for our customers – no more, no less. However, customer needs or demands change over time.

The EcoStruxure™ Power system is scalable from light commercial and industrial buildings to critical facilities such as hospitals, data centers or infrastructure such as airports, rail and oil and gas. The scalability of EcoStruxure™ Power means it also grows and evolves with changing needs or demands through its modular architecture.

EcoStruxure™ Power architectures are fully flexible power distribution systems with the ability to adapt to dynamic and ever-changing conditions, such as balancing supply and demand by the hour or minute or adding and then scaling on-site renewable generation capabilities over time. Connecting IT and OT systems into a single, easy-to-manage Ethernet IP network is at the heart of our digitization story. With EcoStruxure™ Power, facility managers can use the data they collect to make realtime decisions to maximize business continuity and optimize operations.

EcoStruxure™ ready solutions

Distributed intelligence

Full range of protection relays

Schneider Electric is a trusted, global provider of protection relays and control solutions, as well as a leader in electrical distribution innovation. Our ranges of protection relays are the result of more than 100 years of manufacturing and power system experience.

Easergy P5 provides access to an extended warranty program when users register their product using the QR code and follow a simple process with the mySchneider mobile app.



Easergy P5: a fusion of new ideas and proven expertise

Easergy P5 combines fresh thinking on modern electrical challenges with a strong heritage from two popular protection relay ranges: Sepam and MiCOM.

Easergy P5's modern, digital features provide a unique combination of services designed to boost operational efficiency and safety for the user.

Product selection, configuration, and ordering have been made easy with the latest online tools. The asset database provides a management platform, which stores and organizes all information securely and is quickly accessible. Easergy SmartApp provides simple access to key functions and settings for non-expert users and enables quick access to information and documentation.



Easergy P5 SmartApp

Easergy P3U 10/20/30

- Feeder and transformer
- Motor
- Voltage
- Frequency
- Capacitor

Easergy P3 Universal protection

The Easergy P3 protection relay family has been developed to cover standard protection needs for industrial and commercial building applications. Thanks to its cost-effective and flexible design, Easergy P3 provides an excellent alternative for various protection applications.

User-friendliness has always been a core value for Schneider Electric products, and the Easergy P3 is no exception, with the unique ability to operate through your smartphone or tablet using the "Easergy SmartApp".

Rapid configuration is achieved using the unique "eSetup Easergy Pro" parameter-setting software, which improves usability.



Easergy P3 SmartApp



MiCOM range

MiCOM range

MiCOM protection provides the user with a choice of cost-optimized solutions for specific protection requirements within the distribution network. The MiCOM relay series offers comprehensive protective function solutions for all power supply systems, as well as for various functional and hardware project.



Sepam range

Sepam range

Sepam series digital protection relays take full advantage of Schneider Electric's experience in electrical network protection to meet your needs with effective protection of life and property.

EcoStruxure™ ready solutions

Extend the safety with the arc fault mitigation relays

Modern society heavily depends on an uninterrupted supply of electric power. Prolonged power outages may cause serious damage, potentially causing human loss and an interruption of service.

An arc flash protection unit is a protective device used to enhance power system availability and assets.

Schneider Electric's range covers a wide range of application, from stand alone protection to a complete system.

Integrated

Protection relay with arc interface



Easergy P3 advanced

- Integrated protection relay with arc detection in 1-box solution
- Connectivity to SCADA via the protection relay
- Smaller foot-print

Standalone



Arc sensor

V125

- Single stand-alone VAMP125 unit, protects busbar connection, circuit-breaker, CTs

Simple system

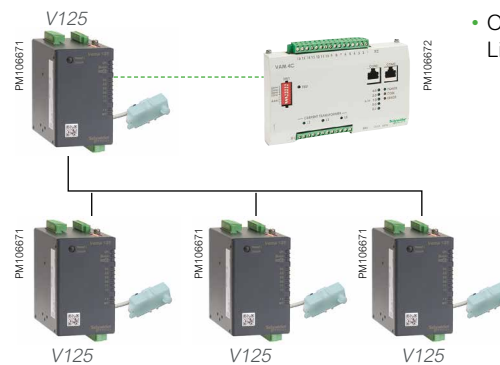
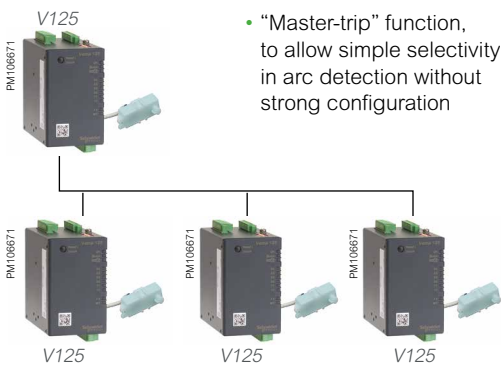

High-end system

- Scalable and Customized Arc Detection system tailored to your needs
- Extended possibilities (number of inputs/outputs, logics, selectivity, etc.)
- Connectible to several serial & Ethernet communication protocols, including IEC 61850
- Multiple technologies (point sensors, loop sensors, fiber optic, etc.)

EcoStruxure™ ready solutions

Real-time condition monitoring to optimize assets availability

Easergy CL110 ambient monitoring

Schneider Electric ambient monitoring system will continuously:

- Help maintenance managers to monitor ambient moisture and pollution which are detrimental to the switchgear
- Automatically calculate the condensation cycle, and combine it with the declared mission profile conditions, so the system can recommend maintenance and cleaning frequency adjustment in order to maintain the switchgear in its nominal status

Easergy TH110 thermal monitoring

Easergy TH110 is part of the new generation of wireless smart sensors ensuring the continuous thermal monitoring of all the critical connections made in the field allowing you to:

- Prevent unscheduled downtimes
- Increase operators and equipments safety
- Optimize and predictive maintenance

Thanks to its compact footprint and its wireless communication, Easergy TH110 allows an easy and widespread installation in a variety of critical points without impacting the performance of the MV Switchgears.

By using Zigbee Green Power communication protocol, Easergy TH110 ensures robust communication that can be used to create interoperable solutions evolving in the Industrial Internet of Things (IIoT) age.

Easergy TH110 is self-powered by the network current and it can ensure optimum performances providing accurate thermal monitoring.

Characteristics

Power supply	Self-powered. Energy harvested from power circuit.
Accuracy	+/- 1°C
Range	-25 °C / +115°C
Wireless communication	ZigBee Green Power 2,4 GHz
Dimension - Weight	31 x 31 x 13 mm - 15 g

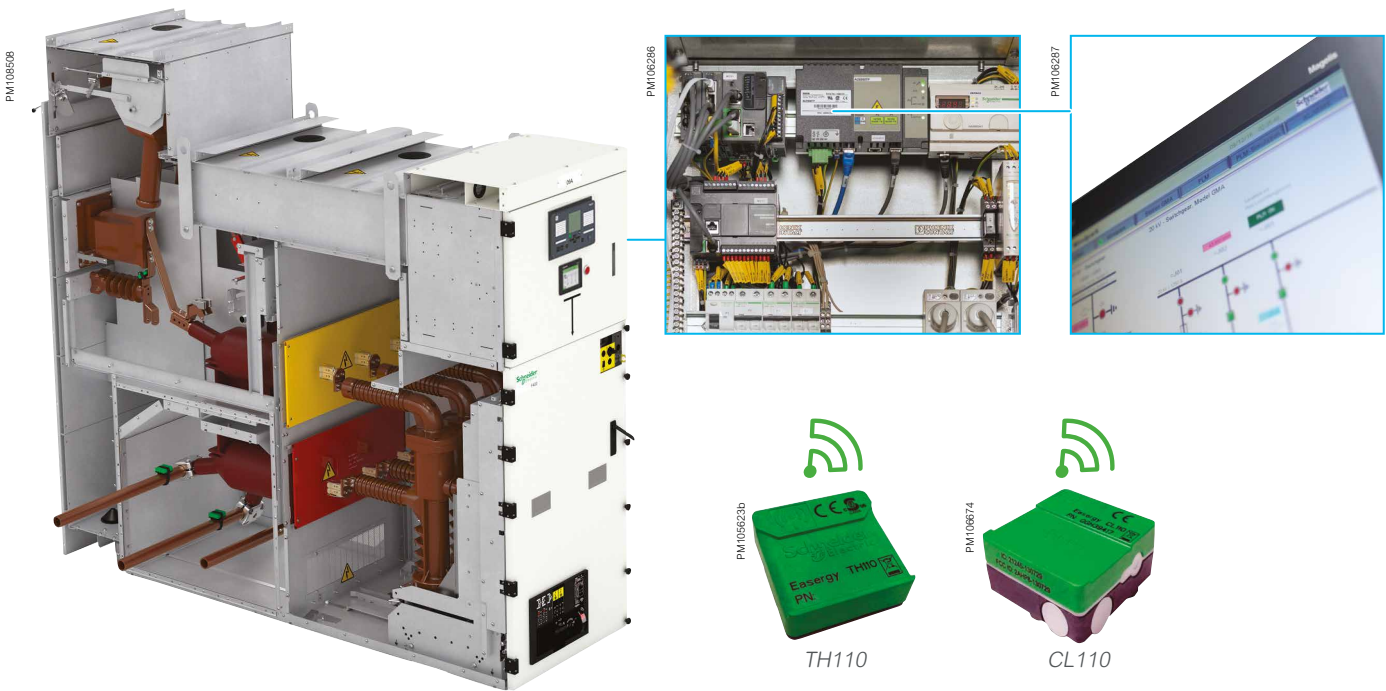

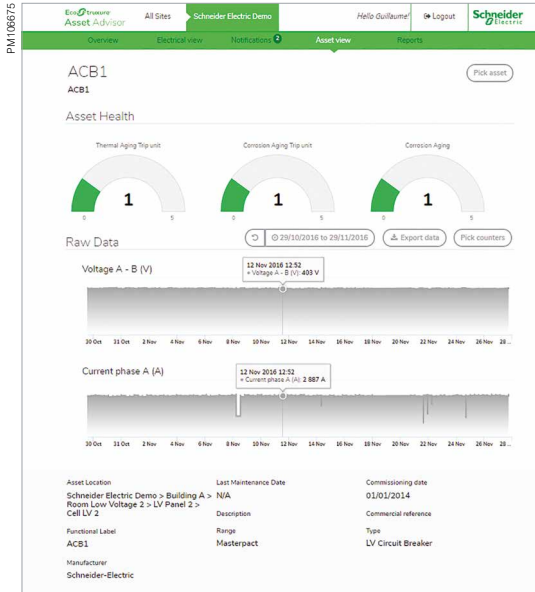

Asset Advisor Dashboard

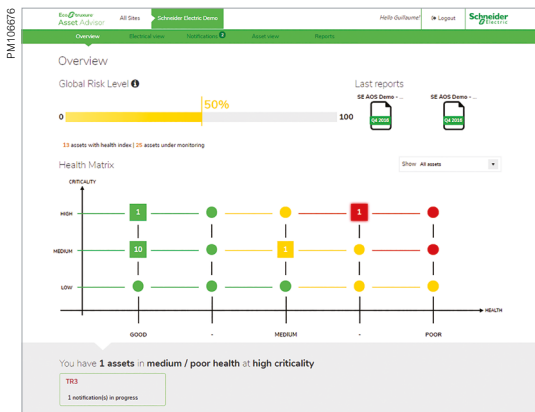

Asset Health Matrix

Schneider Electric approach cybersecurity as a group...

- Data collected through secured gateways
- Secured data transport to prevent data access or manipulation
- Your data are hosted in Schneider Electric Data Center
- Results displayed on secured dashboard (reports, diagnostics, notifications...)
- You remain the owner of your data.

Click [here](#) to download the free version of EcoStruxure Asset Advisor

Apps, analytics & services to improve operations efficiency

Imagine having access to key data about your electrical distribution equipment whenever you need. And experienced professionals who help you make better informed decisions.

That's what you get with EcoStruxure Asset Advisor from Schneider Electric connected service.

You know exactly which assets need to be serviced or replaced. So you can better plan your expenses.

Are you...

- Planning to introduce Condition Base Maintenance (beyond corrective and regular maintenance) with benefits associated to reduced time to address an issue ?
- Looking for innovative solutions to scale their corporate reliability programs? Mostly started on rotatory machines before.
- Striving to dive into IoT complexity with actionable deliverables (not operational alarming)? Or get them defined by manufacturer.

Our EcoStruxure Asset Advisor solution

- Support your journey into predictive maintenance
- Designed for risk of failure mitigation and maintenance optimization
- Turning your data into short term actions and long term decisions
- Our platform is ready-to-use by plug-in connectable electrical assets under our flexible model.
- EcoStruxure Asset Advisor brings tangible benefits on failure risk mitigation and maintenance optimization.

Operation Performance

- Lower unscheduled downtimes
- Increased asset useful life
- Reduce time to fix
- Better compliance with regulations

Financial Efficiency

- Lower Total Cost of Ownership (TCO)
- Decreased failure cost
- Decreased average maintenance cost/fix

Safety

- Reduced personal risk through:
 - Maintenance expertise continuity in high turnover environment
 - Early warning of impending equipment failures

Peace of Mind

- New asset ecosystem insights
- Consistent experience across sites
- Right people at the right time

Quality assurance

Quality certified to ISO 9001

The Quality Management System for the development, production, sales and servicing of PIX has been certified in accordance with ISO 9001:2015.

Certified quality: ISO 9001

At Schneider Electric, customer satisfaction is the Number One priority for everybody:

- We find a solution for each of our customers
- We are enthusiastic about our customers; our thinking and actions are clearly customer-oriented
- We encourage and train our staff to quality requirements

Each Schneider Electric production site has an established functional organization which ensures, monitors and improves quality in line with norms and standards.

This process is:

- Uniform across all sites
- Acknowledged by many customers and recognized organizations

Above all, there is a strict Quality Management System which is audited on a regular basis by the international independent certification company Bureau Veritas.

PM108509



PM108510



Schneider Electric Services

Greater peace of mind throughout your installation lifecycle

How can you cut costs and improve performance at the same time?

When it comes to your electrical distribution infrastructure, the answer is straightforward: get professional expertise.

Life Cycle Services

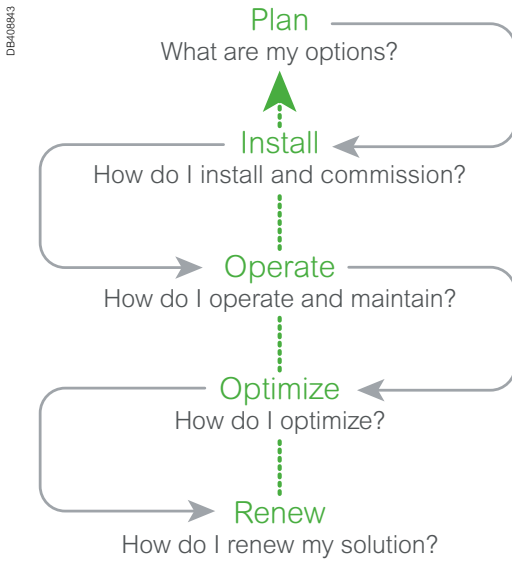

When it comes to your electrical distribution installation, we can help you:

- Mitigate risk and limit downtime
- Keep equipment up to date and extend lifespan
- Cut cost and increase savings
- Improve your return on investment

CONTACT US!

<https://www.schneider-electric.com/en/work/services/>

Plan

Schneider Electric helps you plan the full design and execution of your solution, looking at how to make your process more dependable and optimize time:

- **Technical feasibility studies:** Design a solution in your environment
- **Preliminary design:** Accelerate turnaround time to reach a final solution design

Install

Schneider Electric will help you to install more efficient, more reliable solutions based on your plans.

- **Project management:** Complete your projects on time and within budget
- **Commissioning:** Ensure your actual performance matches the design, through on-site testing and commissioning, and tools and procedures

Operate

Schneider Electric helps you maximize your installation uptime and control your capital expenditures through its services offering.

- **Asset operation solutions:** Provide the information you need to enhance installation performance, and optimize asset maintenance and investment
- **Advantage service plans:** Customize service plans that include preventive, predictive and corrective maintenance
- **On-site maintenance services:** Deliver extensive knowledge and experience in electrical distribution maintenance
- **Spare parts management:** Ensure availability of spare parts and an optimized maintenance budget for your spare parts
- **Technical training:** Build necessary skills and competencies to properly operate your installations

Optimize

Schneider Electric proposes recommendations to help with availability, reliability and quality.

- **MP4 electrical assessment:** Define an improvement and risk management program

Renew

Schneider Electric's solutions extend the original life of your system, while providing upgrades.



Green Premium™

An industry leading portfolio of offers delivering sustainable value



More than 75% of our product sales offer superior transparency on the material content, regulatory information and environmental impact of our products:

- RoHS compliance
- REACH substance information
- Industry leading # of PEP's*
- Circularity instructions



Discover what we mean by green
Check your products!

The Green Premium program stands for our commitment to deliver customer valued sustainable performance. It has been upgraded with recognized environmental claims and extended to cover all offers including Products, Services and Solutions.

CO₂ and P&L impact through... Resource Performance

Green Premium brings improved resource efficiency throughout an asset's lifecycle. This includes efficient use of energy and natural resources, along with the minimization of CO₂ emissions.

Cost of ownership optimization through... Circular Performance

We're helping our customers optimize the total cost of ownership of their assets. To do this, we provide IoT-enabled solutions, as well as upgrade, repair, retrofit, and remanufacture services.

Peace of mind through... Well-being Performance

Green Premium products are RoHS and REACH compliant. We're going beyond regulatory compliance with step-by-step substitution of certain materials and substances from our products.

Improved sales through... Differentiation

Green Premium delivers strong value propositions through third-party labels and services. By collaborating with third-party organizations we can support our customers in meeting their sustainability goals such as green building certifications.

*PEP: Product Environmental Profile (i.e. Environmental Product Declaration)

Range description

Description	22
Technical characteristics	24
Operating conditions and standards	25
Protection of people	26

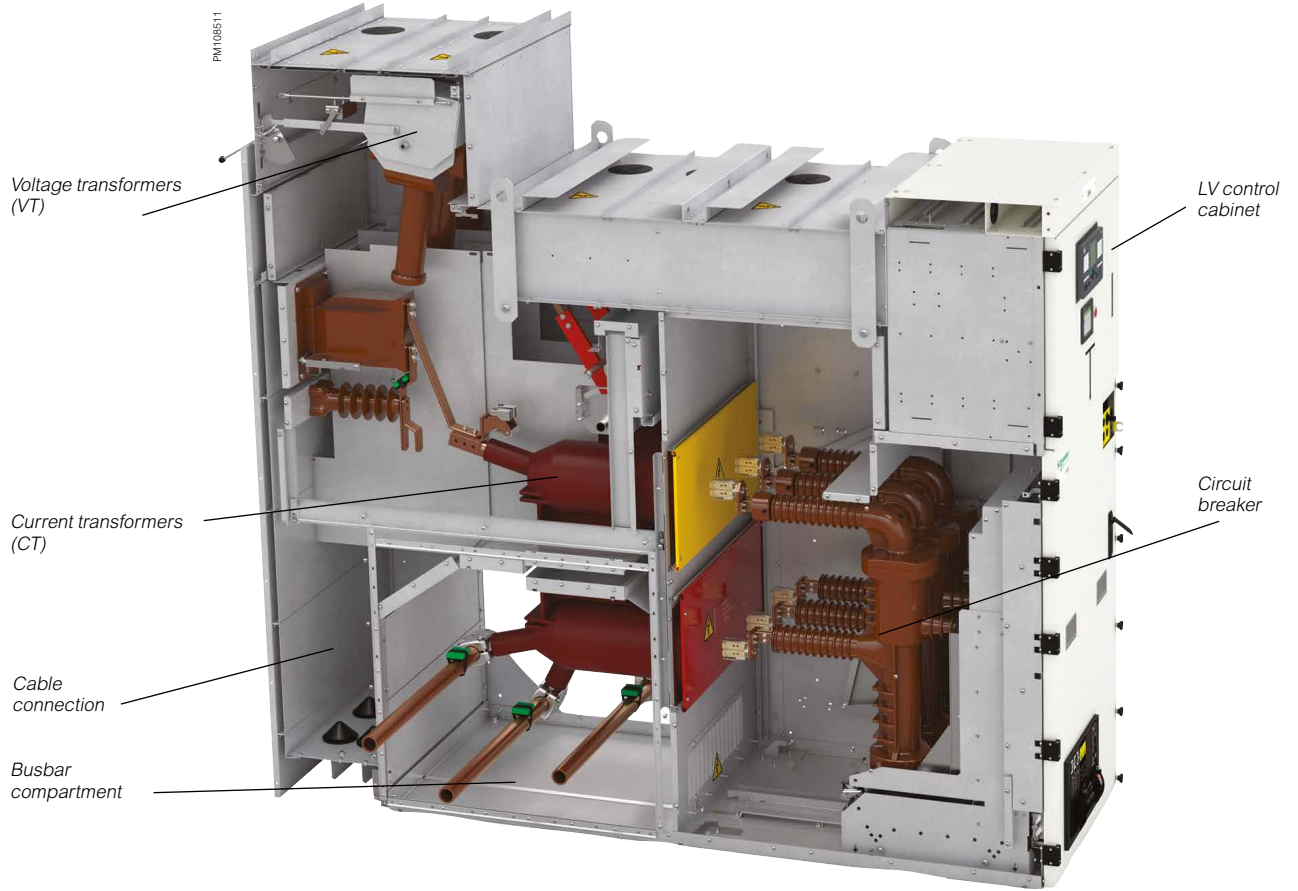

Composition of an F400 switchboard

- F400 switchboards are made up of several interconnected functional units.
- Power connections are made between functional units within a switchboard via a single busbar.
- The electrical continuity of all metal frames is provided by the connection of each functional unit's earthing busbar to the switchboard's main earthing circuit.
- Low voltage wiring trays are provided in the switchboard above the LV control cabinets.
- LV control cables can enter the switchboard through the top and bottom of the cubicle.

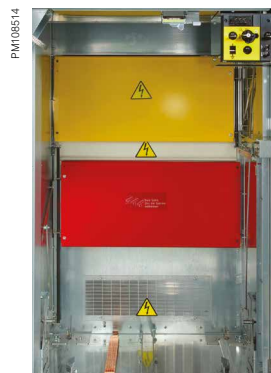

Circuit-breaker compartment



Cable compartment

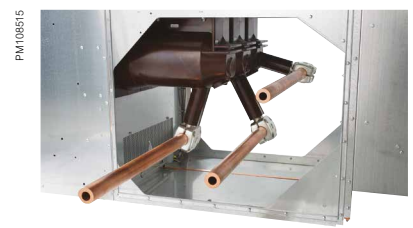

Busbar compartment

LSC2B

(Loss of Service Continuity IEC 62271-200): this category defines the possibility of keeping other compartments energised (in service) when opening a main circuit compartment.

IAC (internal arc classification)

The different sides of metal-enclosed switchgear can have different classes of accessibility. The following codification is used to identify these panels (in accordance with IEC 62271-200).

A: Accessibility restricted to authorized personnel

F: Access to the front panel

L: Access to the side panels

R: Access to the rear panel

The protection, monitoring and control system

This includes:

- Easergy protection, monitoring and control unit
- Arc flash protection system
- Current transformers, which may be of 4 types:
 - functional current transformers
 - DIN current transformers
 - low-power current transformers (LPCT)
 - low voltage toroid type current transformers.
- Voltage transformers:
 - withdrawable fused voltage transformers
 - fixed voltage transformers
- Zero sequence core balance current transformers (CSH type).

The withdrawable part

This includes:

- The circuit-breaker or the earthing unit with its closing and opening mechanism, or the disconnecter unit
- Interlocks to fix the withdrawable part on the fixed part either in service position or disconnected.

Description of a functional unit

A functional unit comprises all the devices in the main and auxiliary circuit which together provide a protection function.

Each functional unit contains all the components which are required to perform this function:

- The cubicle
- The protection, monitoring and control system
- The withdrawable part.

The cubicle

The cubicle is of LSC2B (Loss of Service Continuity Category) type as defined by IEC standard 62271-200, in other words, the medium voltage parts are compartmented using metal partitions (PM class) which are connected to earth and which separate:

- The withdrawable part (circuit-breaker, disconnecter unit or earthing unit)
- The busbars
- Medium voltage connections, earthing switch, current and voltage transformers as required.

The F400 cubicle is available in 2 versions:

- A standard version
- An internal arcing version with IAC-AFLR classification.

The F400 is available with functional and/or DIN current transformers.

The low voltage auxiliaries and monitoring unit are in a low voltage control cabinet separated from the medium voltage section.

The basic functional units provided are:

- | | |
|--|------------------|
| ■ Incomer or feeder with circuit-breaker | AD6 |
| ■ Feeder with fuses | FD6 |
| ■ Direct incomer | RD6 |
| ■ Direct line incomer | AL6 |
| ■ Bus sectioning | CL6 - GL6 |
| ■ Busbar metering (with earthing) | TT6 |
| ■ Busbar metering (with fuses) | PT6 |
| ■ Current and voltage metering | BM6 |

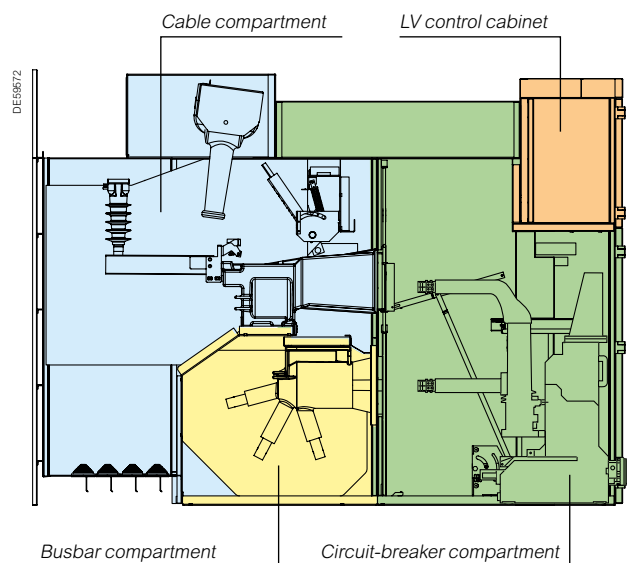

F400 cubicle with IAC-AFLR internal arcing

PM109501



Technical characteristics of the F400 range

The values below are given for normal operating conditions as defined in IEC 62271-1 and IEC 62271-200.

			F400 with Vacuum Breaker		F400 with SF6 Breaker				
Rated voltage									
	Ur	(kV)	36	36	36	36	40.5 (2)		
Rated frequency									
	fr	(Hz)	50/60	50/60	50/60	50/60	50/60		
Rated insulation level									
Power frequency withstand voltage 50 Hz - 1 min			Ud	(kV)	70	70	70	70	85 (4)
Lightning impulse withstand voltage 1.2/50 μs			Up	(kV peak)	170	170	170	170	185
Nominal current and maximum rated short-time withstand current									
Functional unit with circuit-breaker (1)									
Rated short-time withstand current	lth. max	Ik/tk	(kA 3 s)	25	25	25 (3)	25	25	
				31.5	31.5	31.5	31.5	31.5	
				-	-	40	40	-	
Rated normal current	In max busbars	Ir	(A)	1250	-	1250	-	1250	
				2500	2500	2500	2500	-	
	In Circuit Breaker	Ir	(A)	1250	-	1250	-	1250	
				-	2500	-	2500	-	
Internal arc withstand									
			(kA/1 s)	25	25	25	25	25	
			(kA/1 s) (5)	31.5	31.5	31.5	31.5	31.5	
			(kA/0.15 s)	-	-	40	40	-	
Protection degree									
	Enclosure		IPX1/IP3X/IP4X	IPX1/IP3X/IP4X	IPX1/IP3X/IP4X	IPX1/IP3X/IP4X	IPX1/IP3X/IP4X		
Dimensions / Weight									
	Width	mm	900	1100	900	1100	1100		
	Height	mm	2255	2255	2255	2255	2255		
	Depth	mm	3074	3074	3074	3074	3074		
	Approximate weight	kg	1560/1949	1560/1949	1467/1929	1467/1929	1929		

(1) For functional units equipped with circuit-breakers, the breaking capacity is equal to the rated short-time withstand current. In all cases, the peak making capacity is equal to 2.5 times the rated short-time withstand current for 50 Hz and 2.6 times for 60 Hz.

(2) For F400 version with functional current transformers.

(3) Only 50 Hz for SF1.

(4) Ud 95 kV 50 Hz 1 min possible.

(5) With tunnel.



Standards



The F400 meets the following international standards:

- **IEC 62271-1:** High-voltage switchgear and controlgear: common specifications
- **IEC 62271-200:** AC metal-enclosed switchgear and controlgear for rated voltages above 1 kV and up to and including 52 kA
- **IEC 62271-100:** High-voltage switchgear and controlgear - Alternating current circuit-breakers
- **IEC 62271-106:** High-voltage switchgear and controlgear - Alternating current contactors, contactor-based controllers and motor-starters
- **IEC 62271-103:** High-voltage switchgear and controlgear - Switches for rated voltages above 1 kV up to and including 52 kV
- **IEC 60282-1:** High-voltage fuses - Current-limiting fuses
- **IEC 62271-102:** High-voltage switchgear and controlgear - Alternating current disconnectors and earthing switches
- **IEC 60255:** Measuring relays and protection equipment - Common requirements
- **IEC 61869-2:** Instrument transformers - Current transformers
- **IEC 61869-3:** Instrument transformers - Inductive voltage transformers
- **IEC 60044-8:** Instrument transformers - Electronic current transformers
- **IEC 62271-105:** High-voltage switchgear and controlgear - Alternating current switch-fuse combinations
- **IEC 60068-3-3:** Environmental testing - Supporting documentation and guidance - Seismic test methods for equipment
- **IEC 60068-2-6:** Environmental testing -Vibration
- **IEC 62271-210:** High-Voltage switchgear and controlgear; Seismic qualification for metal enclosed switchgear and controlgear assemblies for rated voltages above 1 kV and up to and including 52 kV

Operating conditions

Normal operating conditions in accordance with the IEC International Standards listed below, for indoor switchgear:

- **Ambient air temperature:**
 - Less than or equal to 40°C
 - Less than or equal to 35°C on average over 24 hours
 - Greater than or equal to -5°C.
- **Altitude:**
 - Less than or equal to 1000 m
 - Above 1000 m, a derating coefficient is applied (please consult us).
- **Atmosphere:**
 - No dust, smoke, or corrosive, or inflammable gas and vapor, or gas.
- **Humidity:**
 - Average relative humidity over 24 hours ≤ 95%
 - Average relative humidity over 1 month ≤ 90%
 - Average vapour pressure over 24 hours ≤ 2.2 kPa
 - Average vapour pressure over 1 month ≤ 1.8 kPa.

Specific operating conditions (consult us)

F400 has been developed to meet the following specific conditions:

- High ambient temperature (possible derating)
- High altitudes (possible derating)

Storage conditions

In order to retain all the functional unit's qualities when stored for prolonged periods, we recommend that the equipment is stored in its original packaging, in dry conditions sheltered from the sun and rain at a temperature of between -25°C and +55°C.

GOST certification

The F400 is in accordance with the GOST certification.

The GOST conformity system applies to most of the products sold and used according to Russian standards.

As far as electrical equipment is concerned, this conformity applies when the equipment is used under the following conditions:

- Electrical equipment designed for use in an explosive environment and in mines
- Equipment related to the oil and gas industries: prospecting, exploration, refining, transportation, storage
- Equipment used in the chemical and petrochemical industries and considered to be potentially hazardous because it operates in a toxic, explosive and aggressive environment
- Electrical heating equipment is used to produce ferrous and non-ferrous metal casting

This certification follows the Russian standards:

- GOST 2.601-95
- PB 03-576-03
- PB 03-584-03.

The entire Air Insulated Switchgear range meets the GOST certification requirements.

Annex A of IEC 62271-200 defines the “method for testing the metal-enclosed switchgear under conditions of arcing due to an internal fault”.

The F400 cubicle conforms to this standard and has successfully passed all the type tests specified by this standard. The F400 cubicle is therefore designed to provide suitable degree of protection in the event of an internal fault.

All these performances are available whatever the breaking technology may be (SF6 or Vacuum).

IAC (Internal Arc Classification)

The metal enclosed switchgear may have different types of accessibility on the various sides of its enclosure.

For identification purposes concerning the different sides of the enclosure, the following code shall be used (according to the IEC 62271-200 standard):

- **A:** Restricted access to authorized personnel only. Sides of the enclosure which meet the criteria of the internal arc test
- **F:** Front side
- **L:** lateral side
- **R:** Rear side

F400 internal arc (in conformance with IEC 62271-200)

The F400 internal arc protection is AFLR type in order to help protect operators when they go around the cubicle.

The F400 switchboard is installed in a room with a minimum height of 4 m (for installation in a room under 4 m, please consult us).

F400 is designed to help eliminate the effects of internal arcing safely, by:

- Locating metal flaps above the enclosure to limit overpressure in the compartments in the event of an internal fault
- Using non-flammable materials for the cubicle.
- F400 can be fitted with an optional system to detect internal arcing and disconnect the power supply in order to limit the duration of the fault current to less than 140 ms.

Switchboard operations

The switchboards are installed, operated and maintained from the front panel. Certain installation and maintenance operations are performed from the rear of the cubicle:

- Installation of medium voltage cables
- Operation of voltage transformers.

Dependable mechanical control devices

The switchboards are operated from the front panel.

The user is guided through icon-diagrams on each front panel, making it very easy to understand the operating sequence and the device's status.

Interlocks and padlocks help prevent operator errors.

Several additional levels of security also help protect operators:

- Racking in and out is only possible with the door closed.
- The extensive set of mechanical and electrical interlocks prevent operator error. These can be supplemented by keylocks or padlocks according to specific operating procedures.
- Each selector can be fitted with one to three padlocks.
- All operations are carried out from the front panel.
- The voltage present indicator is located on the front panel of the functional unit, in the immediate vicinity of the earthing switch control.

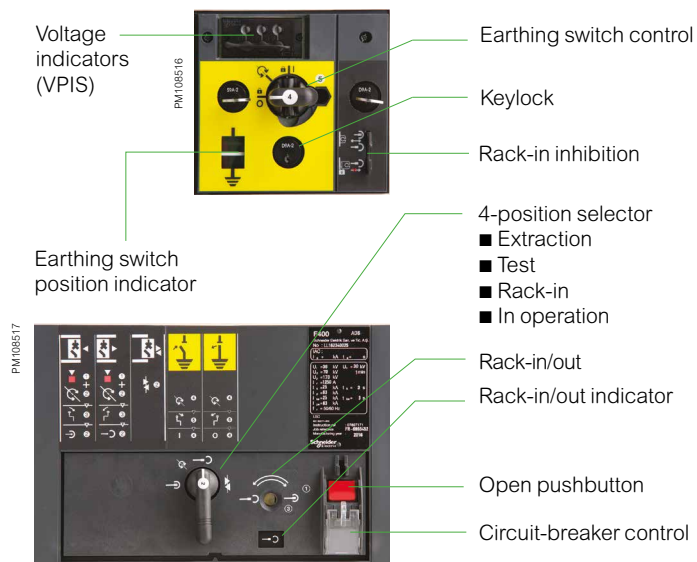

Options

- Circuit-breaker disabling during extraction. This function enables the circuit-breaker control springs to be disabled during the extraction process.
- Rack-in inhibition. This function prevents the withdrawable part from being racked in.

Functions and characteristics

Functional overview	28
Choice of functional units	28
AD6 Incomer or feeder	30
FD6 Feeder with fuses	31
RD6 Direct incomer	32
AL6 Direct line incomer	33
CL6 - GL6 Bus sectioning	34
TT6 Busbar metering (with earthing)	35
PT6 Busbar metering (with fuses)	36
BM6 Current and voltage metering	37

Functional overview

Choice of functional units

The F400 range comprises **several functional applications**. The table below can be used to link requirements to functional units and gives information on the general composition of each unit.

Selection:

You want to supply power to a transformer.
 You have selected a **transformer feeder/breaker**.
 The corresponding **functional unit** will therefore be a **TF-B**, comprising an **AD cubicle** fitted with a withdrawable **circuit-breaker** and a **transformer application**.

Function	Incomer (1)			Feeder			
	Line	Transformer	Generator	Line	Transformer	Motor	Capacitor
Functional unit	LI-B	TI-B	GI-B	LF-B	TF-B	MF-B	CB-B
Cubicle	AD6			AD6			
Device	SF6 or Vacuum Circuit-breaker			SF6 or Vacuum Circuit-breaker			
Protection relays Applications	Substation	Transformer	Generator	Substation	Transformer	Motor	Capacitor
F400 single-line diagrams							
Cubicle	FD6						
Device	Fuse						
Protection relays Applications	Transformer (Maximum Transformer power: 400 kVA)						
F400 single-line diagrams							

(1) The direct incomer is implemented using a specific cubicle: RD6 (same as AD6 without circuit-breaker) or AL6 (only cable connection).

Bus sectioning		Busbar metering		
Switchboard	Substation	BB-V	BB-V	BB-CV
BS-B	SS-B	BB-V	BB-V	BB-CV
CL6 and GL6	AD6	TT6 (with earthing)	PT6	BM6
SF6 or Vacuum Circuit-breaker				
Busbar	Substation	Busbar	Busbar	Busbar
<p>DM107452</p>	<p>DM107453</p>	<p>DM107454</p>	<p>DEE9588</p>	<p>DEE9600</p>

Functional overview

AD6 - Incomer or feeder

Functional unit with circuit breaker is available with 2 different designs.

Type 1 version is with functional current transformers whereas Type 2 version is with DIN current transformers. Earthing switch location is different where it's located in Type 1 before MV cables whereas it's located in Type 2 before CT after CB.

AD6 type 1

(version with functional current transformers)

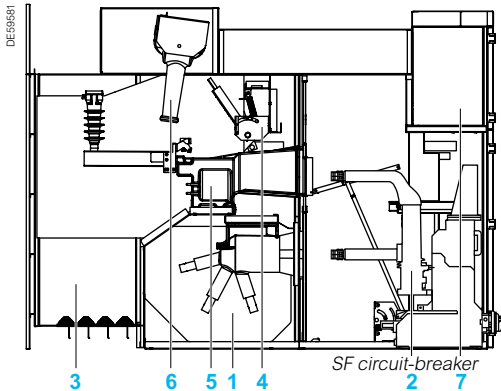

AD6 type 2

(version with DIN current transformers)

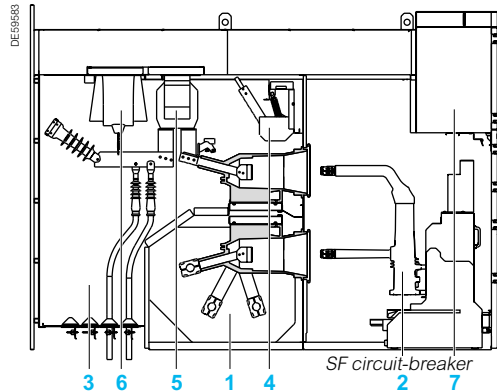

MV components

- 1 Busbars for cubicle interconnection
- 2 Withdrawable part (SF6 & Vacuum circuit-breaker)
- 3 MV connections by cables accessible from the rear
- 4 Earthing switch
- 5 Current transformers
- 6 Voltage transformers (fixed or withdrawable with fuses)

LV control cabinet

- 7 Low voltage auxiliaries and protection, monitoring and control units are in one control cabinet, separated from the medium voltage part.

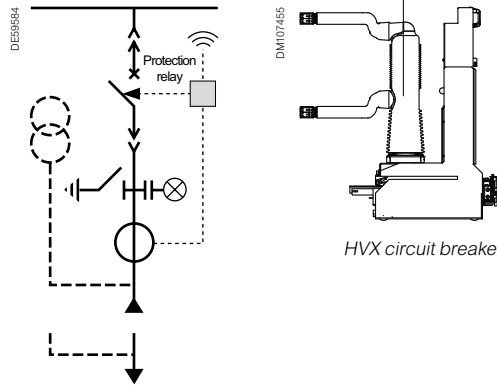
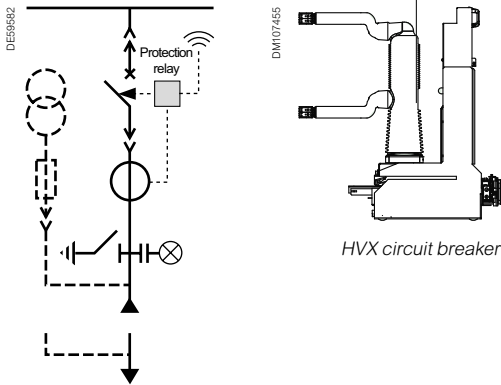

Characteristics		Vacuum Circuit Breaker		SF6 Circuit Breaker		
		AD6 type 1	AD6 type 2	AD6 type 1	AD6 type 2	
Rated voltage	kV	36	36	36	40.5	36
Rated insulation level	kV 50 Hz - 1 min	70	70	70	85(4)	70
	kV impulse 1.2/50 μs	170	170	170	185	170
Busbar current (Busbar intensity)	A					
	1250	■	■	■	■	■
	2500	■	■	■	-	■
Rated current	A					
	630	■	■	■	■	■
	1250	■	■	■	■	■
	2500	■	■	■	-	■
Breaking capacity	kA	25 / 31.5	25	25 / 31.5 / 40	25 / 31.5	25
Short-circuit making current	kA rms 3 s / 60Hz	25 / 31.5	25	25 / 31.5 / 40	25 / 31.5	25
Dimensions	mm					
	Width	900 / 1100	900 / 1100	900 / 1100	1100	900 / 1100
	Height	2255 (1) / 2335 (2)	2255 (1) / 2335 (2)	2255 (1) / 2335 (2)	2255 (1) / 2335 (2)	2255 (1) / 2335 (2)
	Depth	2724 (6) / 3074 / 3274 (5)	2724 (6) / 3074	2724 (6) / 3074 / 3274 (5)	3074 / 3274 (5)	2724 (6) / 3074
Approximate weight (3)	kg	1560/1949	1560/1949	1467/1929	1929	1467/1929

(1) Without voltage transformers

(2) With voltage transformers -

(3) Fully equipped cubicle

(4) Ud 95 kV 50Hz 1 min possible -

(5) In case of use with AD6 type 1 with functional CT and additional CT in the same switchboard

(6) 2724 mm with forced cooling at 2500 A

Functional overview

FD6 - Feeder with fuses

FD6

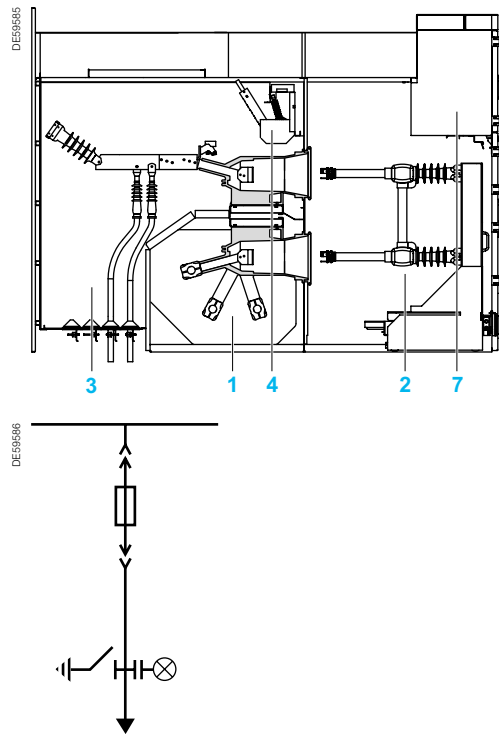

MV components

- 1 Busbars for cubicle interconnection
- 2 Withdrawable part (MV fuse truck)
- 3 MV connections by cables accessible from the rear
- 4 Earthing switch

LV control cabinet

- 7 Low voltage auxiliaries and protection, monitoring and control units are in one control cabinet, separated from the medium voltage part.

Interlocking of the fuse truck and downstream transformer have to be installed to prevent the draw out of fuse truck before de-energizing the transformer, to prevent arcing.
Please consult us in case of this requirement.
Maximum Transformer power : 400MVA.

Characteristics		FD6
Rated voltage	kV	36
Rated insulation level	kV 50 Hz - 1 min	70
	kV impulse 1.2/50 μs	170
Busbar current (Busbar intensity)	A 1250	■
	2500	■
Rated current	A	200
Short-time withstand current	kA rms 1s ⁽¹⁾	20
Rated current	A	20
Dimensions	mm Width	900
	Height	2335
	Depth	2724 ⁽³⁾ / 3074 / 3274 ⁽⁴⁾
Approximate weight ⁽²⁾	kg	1045

(1) Limited by fuses

(2) Fully equipped cubicle

(3) 2724 mm with forced cooling at 2500 A

(4) In case of use with AD6 type 1 with functional CT and additional CT in the same switchboard

Functional overview

RD6 - Direct incomer

RD6

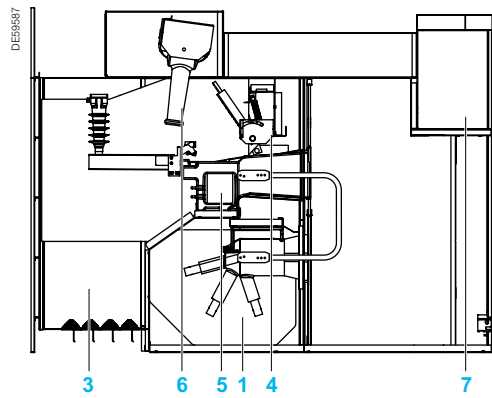

MV components

- 1 Busbars for cubicle interconnection
- 3 MV connections by cables accessible from the rear
- 4 Earthing switch
- 5 Current transformers
- 6 Voltage transformers (fixed or withdrawable with fuses)

LV control cabinet

- 7 Low voltage auxiliaries and protection, monitoring and control units are in one control cabinet, separated from the medium voltage part.

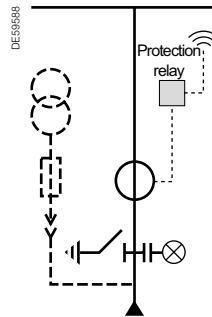

Characteristics		RD6	
Rated voltage	kV	36	40.5
Rated insulation level	kV 50 Hz - 1 min	70	85 (4)
	kV impulse 1.2/50 μs	170	185
Busbar current (Busbar intensity)	A 1250	■	■
	2500	■	-
Rated current	A 630	■	■
	1250	■	■
	2500	■	-
Short-circuit making current	kA rms 3 s / 60Hz	25 / 31.5 / 40	25 / 31.5
Rated current	A	20	
Dimensions	mm Width	900/1100	1100
	Height	2255 (1) / 2335 (2)	2255 (1) / 2335 (2)
	Depth	2724 (6) / 3074 / 3274 (5)	3074 / 3274 (5)
Approximate weight (3)	kg	1367/1729	1729

(1) Without voltage transformers

(2) With voltage transformers -

(3) Fully equipped cubicle

(4) Ud 95 kV 50Hz 1 min possible

(5) In case of use with AD6 type 1 with functional CT and additional CT in the same switchboard

(6) 2724 mm with forced cooling at 2500 A

Functional overview

AL6 - Direct line incomer

AL6

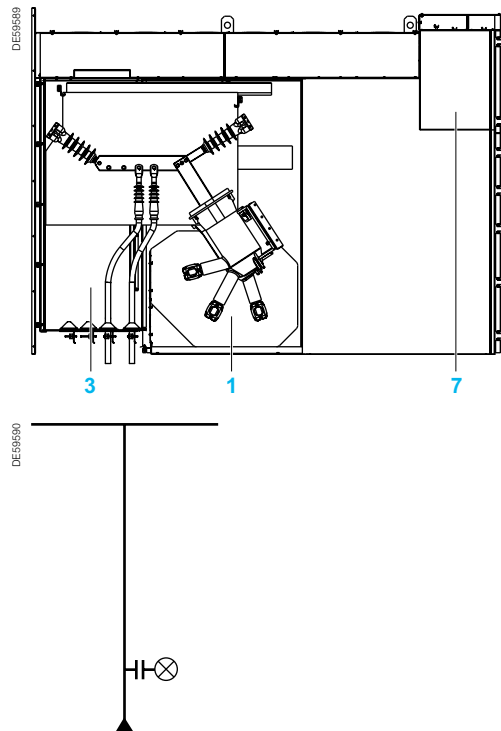

MV components

- 1 Busbars for cubicle interconnection
- 3 MV connections by cables accessible from the rear

LV control cabinet

- 7 Low voltage auxiliaries and protection, monitoring and control unit are in one control cabinet, separated from the medium voltage part.

Characteristics		AL6
Rated voltage	kV	36
Rated insulation level	kV 50 Hz - 1 min	70
	kV impulse 1.2/50 μ s	170
Busbar current (Busbar intensity)	A 1250	■
	2500	■
Short-time withstand current	kA rms 3 s	25
Dimensions	mm Width	900/1100
	Height	2335
	Depth	2724 (2) / 3074 / 3274 (3)
Approximate weight (1)	kg	660/740

(1) Fully equipped cubicle

(2) 2724 mm with forced cooling at 2500 A

(3) In case of use with AD6 type 1 with functional CT and additional CT in the same switchboard

Functional overview

CL6, GL6 - Line-up Bus sectioning

CL6

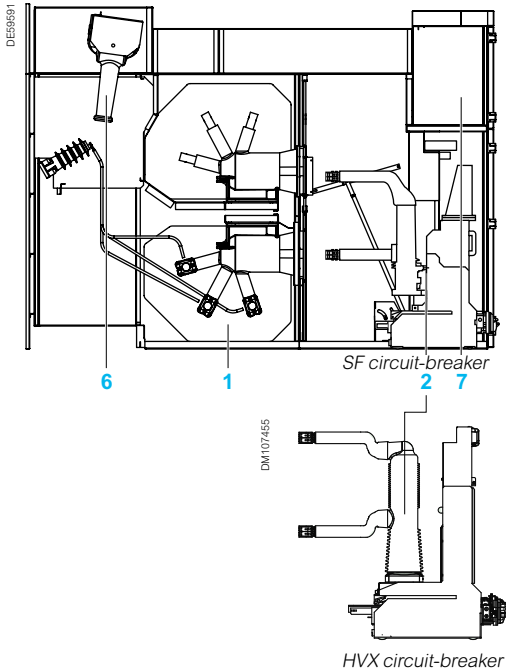

GL6

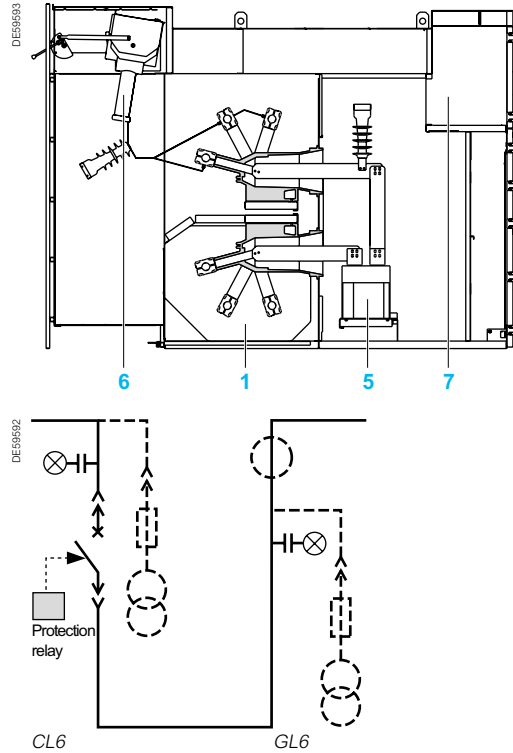

MV components

- 1 Busbars for cubicle interconnection
- 2 Withdrawable part (SF6 & Vacuum circuit-breaker)
- 5 Current transformers
- 6 Voltage transformers (fixed or withdrawable with fuses)

LV control cabinet

- 7 Low voltage auxiliaries and protection, monitoring and control unit are in one control cabinet, separated from the medium voltage part.

Characteristics		Vacuum Circuit Breaker		SF6 Circuit Breaker			
		CL6		GL6			
Rated voltage	kV	36	36	40.5	36	40.5	
Rated insulation level	kV 50 Hz - 1 min	70	70	85 (4)	70	85 (4)	
	kV impulse 1.2/50 μs	170	170	185	170	185	
Busbar current (Busbar intensity)	A 1250	■	■	■	■	■	
	A 2500	■	■	-	■	-	
Rated current	A 1250	■	■	■	■	■	
	A 2500	■	■	-	■	-	
Breaking capacity	kA	25 / 31.5	25 / 31.5 / 40	25 / 31.5	-	-	
Short-circuit making current	kA rms 3 s / 50Hz						
	kA rms 3 s / 60Hz	25 / 31.5	25 / 31.5 / 40	25 / 31.5	25 / 31.5 / 40	25 / 31.5	
Dimensions	mm	Width	900 / 1100	900 / 1100	1100	1100	
		Height	2255 (1) / 2335 (2)	2255 (1) / 2335 (2)	2255 (1) / 2335 (2)	2255 (1) / 2335 (2)	2255 (1) / 2335 (2)
		Depth	2724 (6) / 3074 / 3274 (5)	2724 (6) / 3074 / 3274 (5)	3074 / 3274 (5)	2724 (6) / 3074 / 3274 (5)	3074 / 3274 (5)
Approximate weight (3)	kg	1405/1555	1312/1462	1462	1119	1119	

(1) Without voltage transformers
 (2) With voltage transformers -
 (3) Fully equipped cubicle
 (4) Ud 95 kV 50Hz 1 min possible -
 (5) In case of use with AD6 type 1 with functional CT and additional CT in the same switchboard
 (6) 2724 mm with forced cooling at 2500 A

Functional overview

TT6 - Bus Metering (with earthing)

TT6

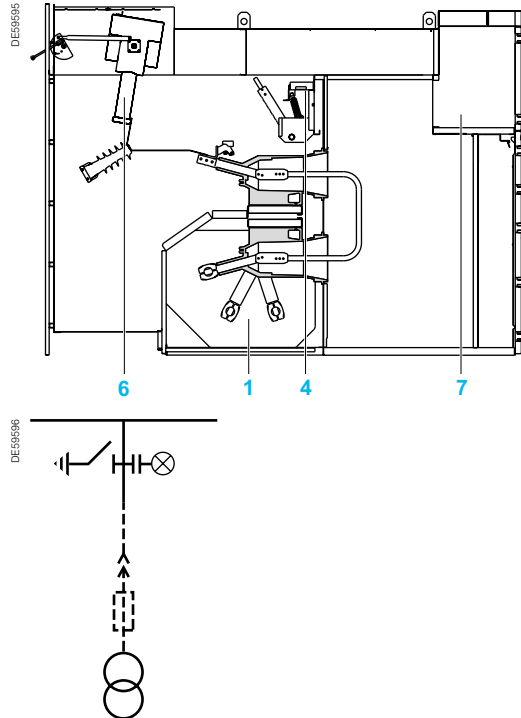

MV components

- 1 Busbars for cubicle interconnection
- 2 Withdrawable part (MV fuse truck)
- 4 Earthing switch
- 6 Voltage transformers (fixed or withdrawable with fuses)

LV control cabinet

- 7 Low voltage auxiliaries and protection, monitoring and control unit are in one control cabinet, separated from the medium voltage part.

Characteristics		TT6	
Rated voltage	kV	36	40.5
Rated insulation level	kV 50 Hz - 1 min	70	85(4)
	kV impulse 1.2/50 μs	170	185
Busbar current (Busbar intensity)	A 1250	■	■
	2500	■	-
Short-time withstand current	kA rms 3 s	25 / 31.5 / 40	25 / 31.5
Dimensions	mm		
	Width	900	1100
	Height	2255 (1) / 2335 (2)	2255 (1) / 2335 (2)
	Depth	2724 (6) / 3074 / 3274 (5)	3074 / 3274 (5)
Approximate weight (3)	kg	1125	1255

(1) Without voltage transformers

(2) With voltage transformers -

(3) Fully equipped cubicle

(4) Ud 95 kV 50Hz 1 min possible

(5) In case of use with AD6 type 1 with functional CT and additional CT in the same switchboard

(6) 2724 mm with forced cooling at 2500 A

Functional overview

PT6 - Bus Metering (with fuses)

PT6

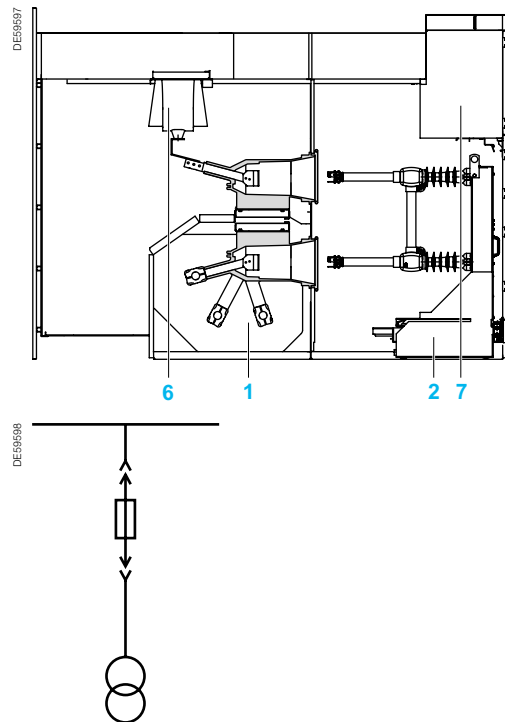

MV components

- 1 Busbars for cubicle interconnection
- 2 Withdrawable part (MV fuse truck)
- 6 Voltage transformers (fixed or withdrawable with fuses)

LV control cabinet

- 7 Low voltage auxiliaries and protection, monitoring and control units are in one control cabinet, separated from the medium voltage part.

Characteristics		PT6
Rated voltage	kV	36
Rated insulation level	kV 50 Hz - 1 min	70
	kV impulse 1.2/50 μs	170
Busbar current (Busbar intensity)	A 1250	■
	2500	■
Short-time withstand current (1)	kA rms 3 s	20
Dimensions	mm Width	900
	Height	2335
	Depth	2724 (3) / 3074 / 3274 (4)
Approximate weight (3)	kg	945

(1) Without voltage transformers

(3) 2724 mm with forced cooling at 2500 A

(4) In case of use with AD6 type 1 with functional CT and additional CT in the same switchboard

Functional overview

BM6 - Current and Voltage Metering

BM6

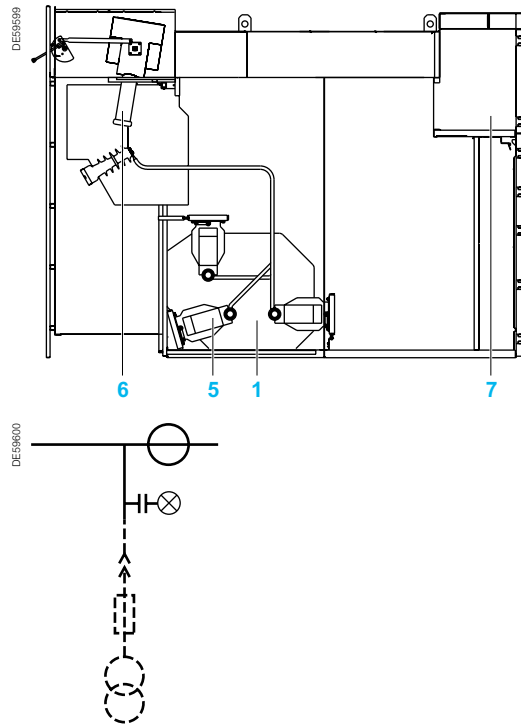

MV components

- 1 Busbars for cubicle interconnection
- 5 Current transformers
- 6 Voltage transformers (fixed or withdrawable with fuses)

LV control cabinet

- 7 Low voltage auxiliaries and protection, monitoring and control units are in one control cabinet, separated from the medium voltage part.

Characteristics		BM6
Rated voltage	kV	36
Rated insulation level	kV 50 Hz - 1 min	70
	kV impulse 1.2/50 μ s	170
Busbar current (Busbar intensity)	A 1250	■
	2500	■
Short-time withstand current	kA rms 3 s	25 / 31.5 / 40
Dimensions	mm Width	1100
	Height	2255 (1) / 2335 (2)
	Depth	2724 (4) / 3074 / 3274 (5)
Approximate weight (3)	kg	920/980

(1) Without voltage transformers

(2) With voltage transformers -

(3) Fully equipped cubicle

(4) 2724 mm with forced cooling at 2500 A

(5) In case of use with AD6 type 1 with functional CT and additional CT in the same switchboard



Components and accessories

Withdrawable parts	40
<hr/>	
SF circuit breakers	41
Selection guide	41
Operating mechanism	42
Circuit opening function	43
Remote control function	44
Indication and locking/interlocking function	45
Operation	46
<hr/>	
HVX circuit breakers	47
Selection guide	47
Operating mechanism	48
Circuit opening function	49
Remote control function	50
Indication and locking/interlocking function	51
Operation	52
<hr/>	
Voltage transformers for F400	53
<hr/>	
Current transformers for F400	55
<hr/>	
Protection, monitoring and control	58
Easergy P5 protection relays	58
Easergy P3 protection relays	60
Sepam protection system	61
MiCOM protection system	62
Arc fault protection	63
Thermal monitoring Easergy TH110	65
Wireless Environmental Monitoring Easergy CL110	64

PM109503



Withdrawable parts include:

- The circuit-breaker with its opening and closing mechanism, the disconnecter unit and the earthing unit
 - The racking in/out handle drive mechanism
 - Interlocks for fixing the withdrawable part firmly to the fixed part.
- The live parts are housed in a sealed pressure system type insulating enclosure in compliance with IEC 62271-100.

The devices used to equip the F400 range of functional units have outstanding features:

- Long service life
- Maintenance-free live parts
- High electrical endurance
- Very low overvoltage
- Dependability
- Insensitivity to the environment
- Breaking capacity and dielectric strength maintained at atmospheric pressure

DE58201

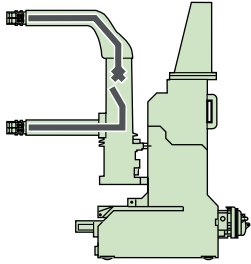

SF6 circuit-breaker

DM107456

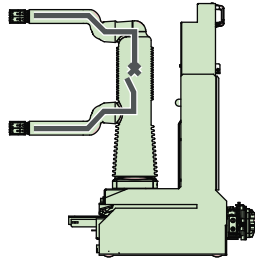

Vacuum circuit-breaker

Circuit-breaker

A circuit-breaker is a safety device used to operate and help protect electrical distribution networks. It is fitted in the F400 cubicle to protect all the downstream components in the event of a short circuit.

There are two techniques of F400 cubicle,

- SF6 circuit breaker
- Vacuum circuit breaker.

DE58680

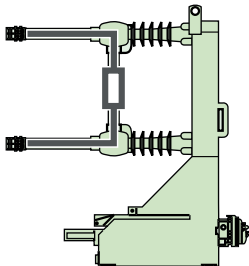

Fuse truck

A fuse truck is the most cost-effective solution to help protect small power transformers.

Maximum Transformer power : 400 kVA.

DE58202

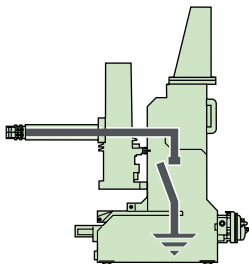

Earthing unit

The earthing unit is a safety feature used to earth the cubicle busbar. It is installed in place of the circuit-breaker and provides many locking possibilities.

DE58203

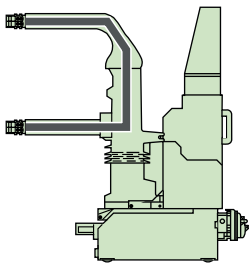

Disconnecter unit

The disconnecter unit enables the upper and lower parts of the cubicle to be short-circuited. It is installed in place of the circuit-breaker and provides the same locking possibilities.

DE57882

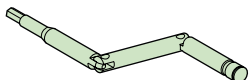

Racking handle

This handle is used to:

- Rack the withdrawable part in/out
- Open/close the earthing switch.

Electrical characteristics according to IEC 62271-100				SF F400				
Rated voltage	Ur	kV 50/60 Hz		36			40.5	
Insulation voltage								
- Power frequency withstand	Ud	kV 50 Hz 1min		70			85 (1)	85 (1)
- Lightning impulse withstand	Up	kV peak		170			185	185
Rated current	Ir	A	1250	■	■	■	■	■
			2500	–	■	■	–	–
Short circuit current	Isc	kA		25 (2)	31,5	40	25 (2)	31,5
Rated short-time withstand current	Ik/tk	kA/3 s		25	31.5	40	25	31.5
Short-circuit making current	I_p	kA peak	50 Hz	62.5	79	100	62.5	79
			60 Hz	–	82	104	–	82
Rated switching sequence	O-3 min-CO-3 min-CO			■	■	■	■	■
	O-0.3 s-CO-3 min-CO			■	■	–	■	■
	O-0.3 s-CO-15 s-CO			■	–	–	–	–
Phase to phase		mm	250	■	■	■	■	■
			300	■	■	■	■	■
Operating mechanism	Frontal			■	■	■	■	■
Operating times	Opening (ms)			< 50				
	Breaking (ms)			< 60				
	Closing (ms)			< 65				
Service temperature	T	°C		–25 to +40				
Mechanical endurance	Class			M2				
	Number of switching operations			10 000				
Electrical endurance	Class			E2				
Capacitive current breaking capacity	Class			C2				

■ Available
 – Not available
 (1) Ud 95 kV 50 Hz 1 min possible
 (2) Only 50 Hz possible.

Specific applications

Switching and protection of capacitor banks

The SF range of circuit-breakers is particularly suitable for switching and protection of capacitor banks; they are classified C2 according to the IEC 62271-100 standard. Tests are carried out according to the standard for breaking at 400 A with making and breaking cycles in the case of a capacitor bank with a making current of 20 kA. Additional tests have been carried out: please consult us.

SF circuit breakers

Operating mechanism

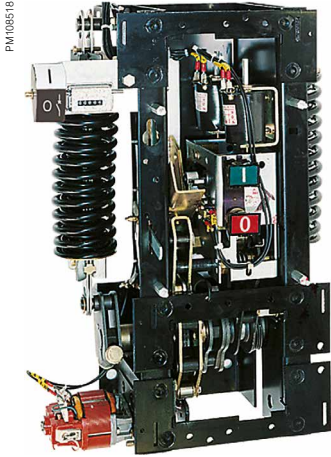

GMH operating mechanism

SF circuit-breakers are actuated by the GMH operating mechanism which ensures that the closing and opening speed of the breaking device is not operator-dependent.

The circuit-breakers are fitted with a GMH electrical operating mechanism. They are used for remote operation and to ensure a fast resetting cycle.

The GMH electrical operating mechanism includes:

- An energy accumulation mechanism that stores, in the springs, the energy required to close and open the breaker
- A manual lever-operated resetting device
- An electrical motor-operated resetting device that automatically resets the control as soon as the breaker closes (time ≤ 15 s)
- A mechanical opening and closing device operated by two pushbuttons on the front panel
- An electrical closing device including:
 - A closing release for remote control with an anti-pumping relay.
- An electrical opening device including one or more opening releases that may be one of the following types:
 - Power on
 - Undervoltage
 - Low power consumption Mitop(1).
- An operation counter
- An optional reset control indication contact
- A resetting limit switch contact
- A black/white mechanical "open-closed" position indicator
- A multi-pin connector to isolate auxiliary circuits in the "racked out" position.

(1) Mitop: release with its own optional current used in combination with the Sepam 100 LA protection relay.

GMH circuit-breaker operating mechanism

Auxiliaries diagram

- | | |
|----------------|---|
| J | Circuit-breaker |
| M | Spring charging motor |
| YF | Closing release |
| M1-M2 | End-of-charging contact |
| QF | Auxiliary circuit-breaker contacts |
| KN | Anti-pumping relay |
| SE | Latched release contact |
| Y01-Y02 | "Shunt" opening releases |
| YM | Undervoltage opening release |
| "Mitop" | "Mitop" opening release (with its own current) |
| M3 | Operating mechanism charged contact |
| SP | Pressure switch contact |
| SQ | Device ready-to-operate contact |
| Sm1 | Closing pushbutton (external) |
| Sm2 | Opening pushbutton for shunt releases (external) |
| Sm3 | Opening pushbutton for undervoltage releases (external) |
| Sn | Closing disabling contact (external) |

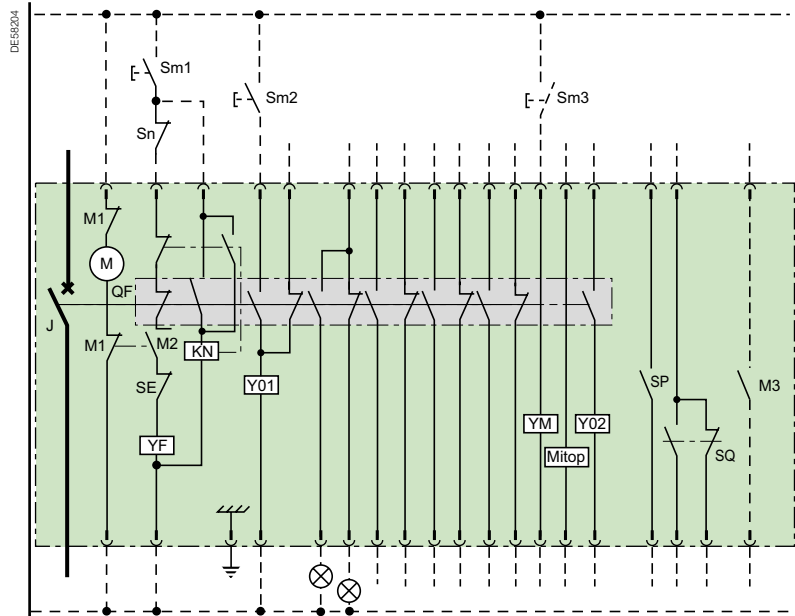

SF circuit breakers

Circuit opening function

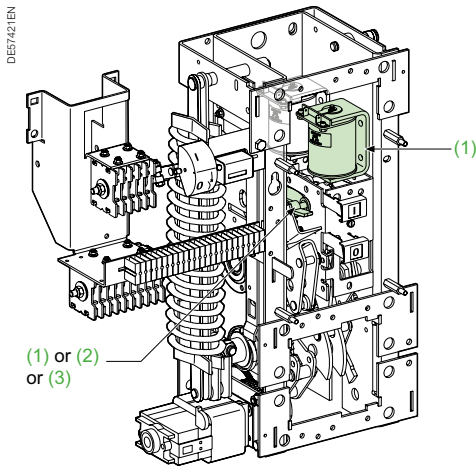

Composition

The circuit opening function can be implemented using the following components:

- A shunt opening release (on energizing) (YO1)
- A second shunt opening release (on energizing) (YO2)
- Undervoltage release (YM)
- Low energy release (Mitop).

Note: see the table of the releases' combinations page "Order form".

Shunt opening release (YO1 and YO2)

Energizing this unit causes instant opening of the circuit breaker.

Characteristics

Power supply	See "Order form" page	
Threshold	V AC	0.85 to 1.1 Ur
	V DC	0.7 to 1.1 Ur
Consumption	V AC	160 VA
	V DC	50 W

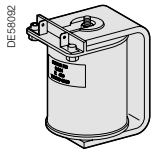

Shunt opening release (1)

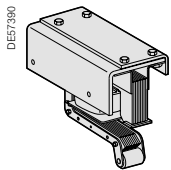

Undervoltage release (2)

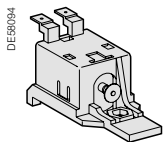

Low energy release (3)

Undervoltage release (YM)

This release unit causes systematic opening of the circuit breaker when its supply voltage drops below a value less than 35% of the rated voltage, even if this drop is slow and gradual. It can open the circuit breaker between 35% and 70% of its rated voltage. If the release unit is not supplied with power, manual or electrical closing of the circuit breaker is impossible. Closing of the circuit breaker is compulsory when the supply voltage of the release unit reaches 85% of its rated voltage.

Characteristics

Power supply	See "Order form" page		
Threshold	Opening	0.35 to 0.7 Ur	
	Closing	0.85 Ur	
Consumption	Triggering	V AC	400 VA
		V DC	100 W
	Latched	V AC	100 VA
		V DC	10 W

Low energy release (Mitop)

This specific release unit comprises a low consumption unit.

Characteristics

Power supply	Direct current
Threshold	$0.04 A < I < 0.12 A$

Any tripping due to the Mitop release unit is momentarily indicated by an SDE type changeover contact (option).

SF circuit breakers

Remote control function

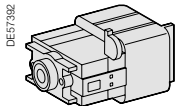
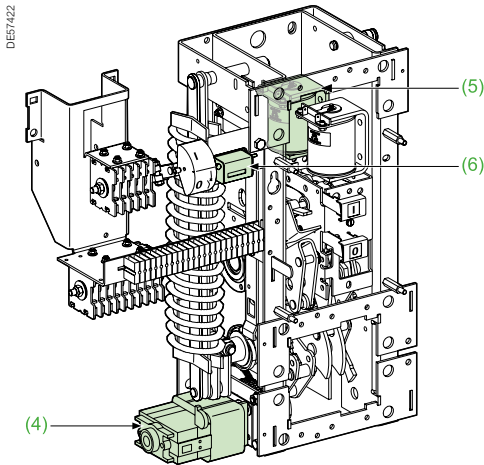

Electric motor (4)

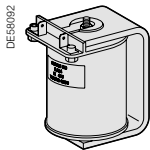

Shunt closing release (5)

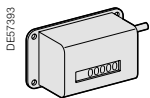

Operation counter (6)

Function

Remote control enables remote opening and closing of the circuit breaker.

Composition

The remote control mechanism comprises:

- An electric motor with gearing
- A shunt closing release (YF) combined with an anti-pumping device
- An operation counter.

Electric motor (M)

The electric motor performs automatic rearming of the stored energy unit as soon as the circuit breaker is closed. This allows the instant reclosing of the device after opening. The arming lever is used only as a backup operating mechanism in the event of absence of the auxiliary power supply.

The M3 contact indicates the end of arming operations.

Characteristics

Power supply	See "Order form" page	
Threshold	V AC/V DC	0.85 to 1.1 Ur
Consumption	V AC	380 VA
	V DC	380 W

Shunt closing release (YF)

This release allows remote closing of the circuit breaker when the operating mechanism is armed.

Characteristics

Power supply	See "Order form" page	
Threshold	V AC	0.85 to 1.1 Ur
	V DC	0.85 to 1.1 Ur
Consumption	V AC	160 VA
	V DC	50 W

The shunt closing release is combined with an anti-pumping relay that enables priority to be given to opening in the case of a permanent closing order.

This thus avoids the device being caught in an uncontrolled opening-closing cycle.

Operation counter

The operation counter is visible on the front panel.

It displays the number of switching cycles (C-O) that the device has carried out.

SF circuit breakers

Indication and locking/interlocking function

DEE7423

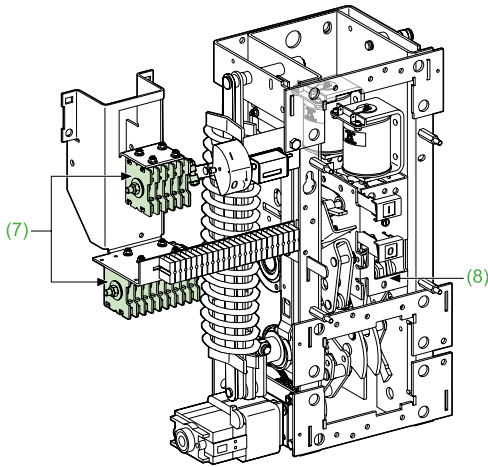

Operating mechanism

DEE7394

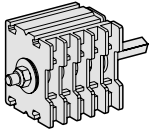

Auxiliary contacts (7)

DEE7395

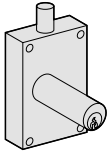

Keylocking kit (8)

“Open/closed” auxiliary contacts

The number of contacts available depends on the options chosen on the operating mechanism.

In the basic configuration, the circuit breaker’s operating mechanism comprises a total of:

- 5 normally closed contacts (NC)
- 5 normally open contacts (NO)
- 1 changeover contact (CHG).

The usage procedure for auxiliary contacts is given in the following table:

Options	NC contact	NO contact
Shunt opening release (each one)	0	1
Undervoltage release	0	0
Low energy release (Mitop)	0	0

In order to know the final number of available contacts, you must deduct from the total number of contacts contained in the circuit breaker (5 NC + 5 NO + 1 CHG) the number of contacts used, as given in the table above.

E.g.: a circuit breaker equipped with a remote control and a shunt trip unit has the following available contacts:
5 NC + 4 NO + 1 CHG.

With an undervoltage release instead of the shunt trip, this circuit breaker would have the following available contacts:
5 NC + 5 NO + 1 CHG.

Shunt opening release combination			
1st release	Shunt opening release YO1	Undervoltage release YM	Mitop
2nd release			
Without	5NC + 4NO + 1CHG	5NC + 5NO + 1CHG	
Shunt opening release YO2	5NC + 3NO + 1CHG	5NC + 4NO + 1CHG	5NC + 4NO + 1CHG
Undervoltage release YM	5NC + 4NO + 1CHG		5NC + 5NO + 1CHG
Mitop	5NC + 4NO + 1CHG	5NC + 5NO + 1CHG	

Locking the circuit breaker in the “open” position

This key-operated device allows the circuit breaker to be locked in the “open” position. The circuit breaker is locked in the open position by blocking the opening push button in the “engaged” position.

Locking is achieved using a Profalux or Ronis captive key type keylock.

PMT108519



PMT108520



SF range

SF circuit-breakers work on the basis of the “puffer” type principle in SF₆, which is used as a breaking and insulating gas. Each of the three poles is independent and has a sealed pressure system type insulating enclosure in compliance with IEC 62271-1. Each pole forms a gas-tight unit filled with SF₆ at a low relative pressure of 0.25 to 0.35 MPa (2.5 to 3.5 bar) depending on the performance level required. A pressure switch on each pole operates an alarm in the event of a pressure drop. SF range circuit-breakers are actuated by a GMH energy accumulation control.

SF₆ gas for circuit-breakers

Sulphur hexafluoride (SF₆) provides the insulation and breaking functions in SF circuit-breakers. The live parts are housed in an insulating enclosure which is sealed for life, as specified in IEC 62271-100.

The switchgear used in the F400 cubicles has the following characteristics:

- Long service life
- Maintenance-free live parts
- High electrical endurance
- Very low overvoltage
- Dependability
- Independent of the environment
- Possibility of continuous monitoring of the circuit-breaker status.

PE55037



Fig. 1



Fig. 2



Fig. 3



Fig. 4

Puffer: operating principle

The main contacts and arcing contacts are initially closed (Fig. 1).

Pre-compression (Fig. 2)

When the contacts begin to open, the piston compresses the SF₆ gas slightly in the compression chamber.

Arcing period (Fig. 3)

The arc appears between the arcing contacts. The piston continues its movement. A small quantity of gas, directed by the insulating nozzle, is injected across the arc. For low current breaking, the arc is cooled by forced convection. However, for high current breaking, thermal expansion causes the hot gases to move towards the cooler parts of the unit. The distance between the two arcing contacts then becomes sufficient for the current to be broken permanently when it first reaches the zero point, due to the dielectric properties of the SF₆.

Sweeping overtravel (Fig. 4)

The moving parts finish their movement and the injection of cold gas continues until the contacts are completely open.

Electrical characteristics according to IEC 62271-100			HVX			
Rated voltage	Ur	kV 50/60 Hz	36	36	36	36
Insulation voltage						
- Power frequency withstand	Ud	kV 50 Hz 1min	70	70	70	70
- Lightning impulse withstand	Up	kV peak	170	170	170	185
Rated current	Ir	A				
		1250	■	–	■	–
		2500	–	■	–	■
Short circuit current	Isc	kA	25	25	31.5	31.5
Rated short-time withstand current	Ik/tk	kA/3 s	25	25	31.5	31.5
Short-circuit making current	I_p	kA peak				
		50 Hz	63	63	80	80
		60 Hz	63	63	80	80
Rated switching sequence		O-3 min-CO-3 min-CO	■	■	■	■
		O-0.3 s-CO-15 s-CO	■	■	■	■
		O-0.3 s-CO-3 min-CO	■	■	■	■
Phase to phase		mm				
		300	■	■	■	■
Operating mechanism		Frontal	■	■	■	■
Operating times		Opening (ms)	35-53	35-53	35-53	35-53
		Breaking (ms)	2-15	2-15	2-15	2-15
		Closing (ms)	40-63	40-63	40-63	40-63
Service temperature	T	°C	-25 to +40	-25 to +40	-25 to +40	-25 to +40
Mechanical endurance		Class	M2	M2	M2	M2
		Number of switching operations	10,000	10,000	10,000	10,000
Electrical endurance		Class	E2	E2	E2	E2
Capacitive current breaking capacity		Class	C2	C2	C2	C2

■ Available
– Not available

DM103391

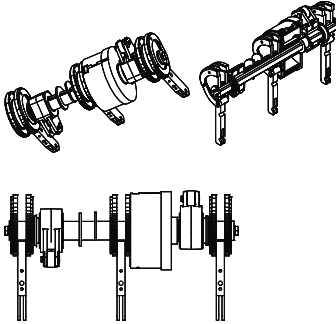

Operating mechanism

The operating mechanisms have been simplified to increase reliability and give extended life with very low maintenance. Instead of the traditional spring operating mechanism, the HVX series incorporates a single-shaft system and only one torsion spring, reducing the number of parts and increasing reliability. The cam output from three independent phases is ideal for the vacuum switch. The transmission mechanism's one-step output and the special axletree design provides optimum transmission efficiency to ensure energy saving and a stable, reliable mechanism.

Operating principle

Energy is stored in the spiral spring by means of the electric motor or manual crank. Opening and closing of the vacuum interrupter is controlled by the cam; upon closing, the spring automatically restores the energy for an integrated automatic on/off operating cycle.

An on/off storage mechanism, with its special mechanism, can absorb the excess energy of the drive mechanism through a quick on/off operation.

The operating mechanism has electric and manual charging devices.

The relevant interlock help prevent manipulation errors after energy storage.

Electrical circuit diagram HVX with anti-pumping relay

1. This circuit diagram shows the maximum switchgear equipment. The standard equipment doesn't include option items, if the customer requires option items, please state it when placing the order.
2. Circuit-breaker is in discharge and open position, trolley is in service position, blocking magnet for closing is de-energised.

- Q0** Units incorporated in the circuit breaker in compliance with order
- XM** Low Voltage connector
- B** Terminal block
- S11/S12** Auxiliary contacts (switch position indicator)
- S61** Micro switch actuated by operation
- K01** Anti-pumping relay
- Y1** Blocking magnet for closing (option)
- S6** Micro switch for blocking magnet
- S2** Micro switch for motor control
- M1** Motor for energy starting device
- F4** Under voltage release (option)
- F3** Indirect overcurrent release (option)
- F2** Auxiliary closing release
- F12** 2. Auxiliary opening release(option)
- F11** 1. Auxiliary opening release
- SDR** Automatic unloading switch in pulling out position

Drive spring-charging mechanism using a crank

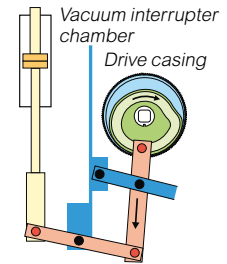
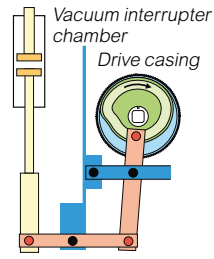
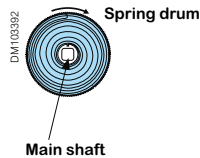

DM107457

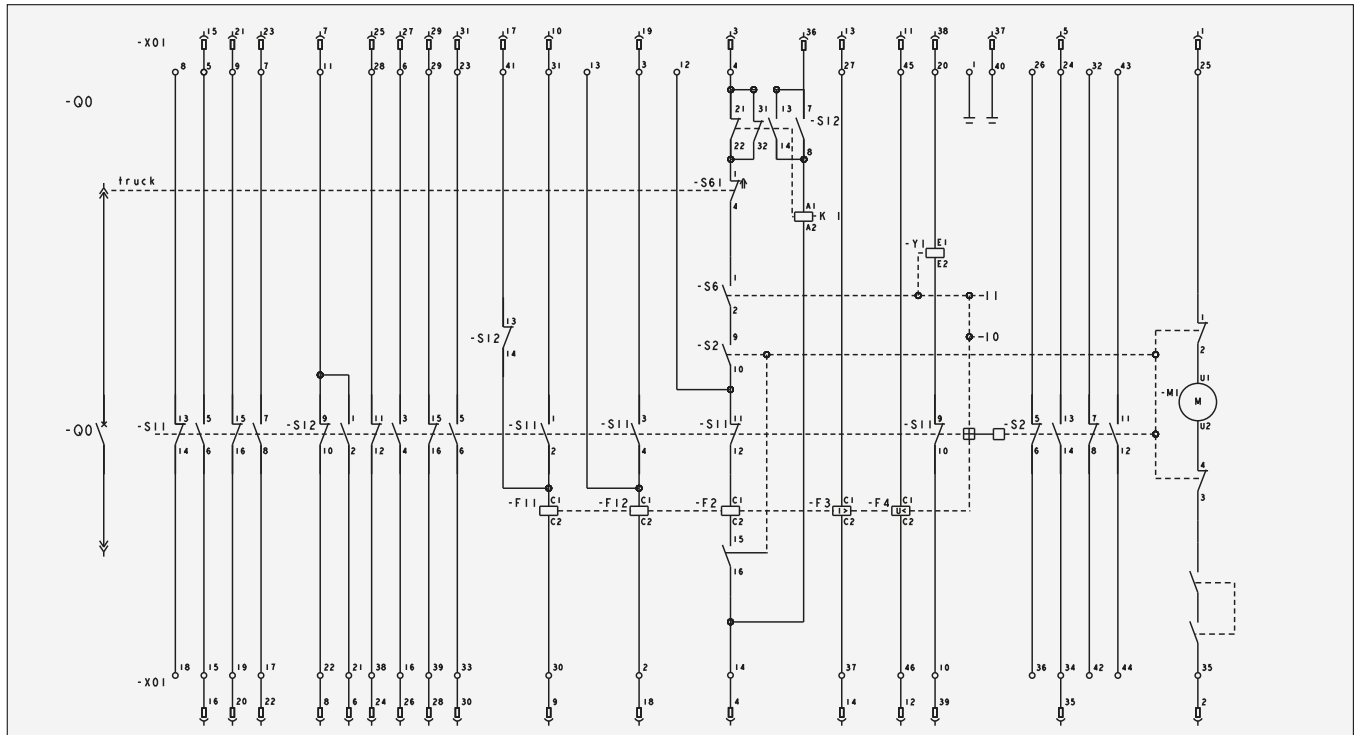

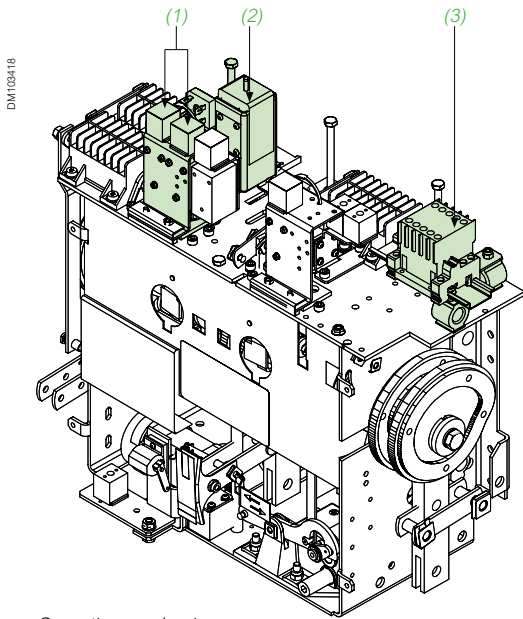

Operating mechanism

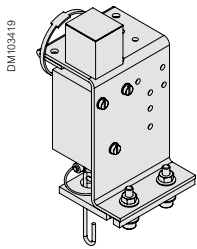

Auxiliary release F11/F12 (1)

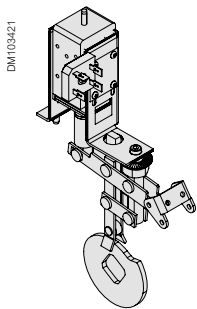

Under-voltage release F4 (2)

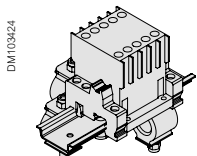

Anti-pumping relay K01 (3)

Composition

The circuit opening function can be implemented using the following components:

- Auxiliary release F11/F12
- Under-voltage release F4
- Anti-pumping relay K01.

Auxiliary release F11/F12

The auxiliary release coil is actuated by the auxiliary power supply. The coil is designed for short-term operation only; its main circuit is therefore routed via an auxiliary switch contact controlled by the circuit breaker shaft, and upon release it interrupts the current circuit.

Characteristics

Power supply	V AC	110/220
	V DC	24/48/110/220
Threshold	V AC	0.85 to 1.1 Ur
	V DC	0.85 to 1.1 Ur
Consumption	V AC	180 W
	V DC	180 W

Under-voltage release F4

Under-voltage releases are used for the auxiliary boost voltage return circuit. Whenever the auxiliary current is interrupted or its voltage drops significantly, the switching device is immediately tripped.

Characteristics

Power supply	V AC	110/220
	V DC	24/48/110/220
Threshold	Closing	0.35 to 0 Ur
Consumption	V AC	approx. 12 W
	V DC	approx. 12 W

Anti-pumping relay K01

If both ON and OFF commands are permanently present on the circuit breaker at the same time, the latter returns to open position after closing; it remains in this open position until the ON command is issued again. This prevents continuous closing and opening (i.e. "anti-pumping").

DM103418

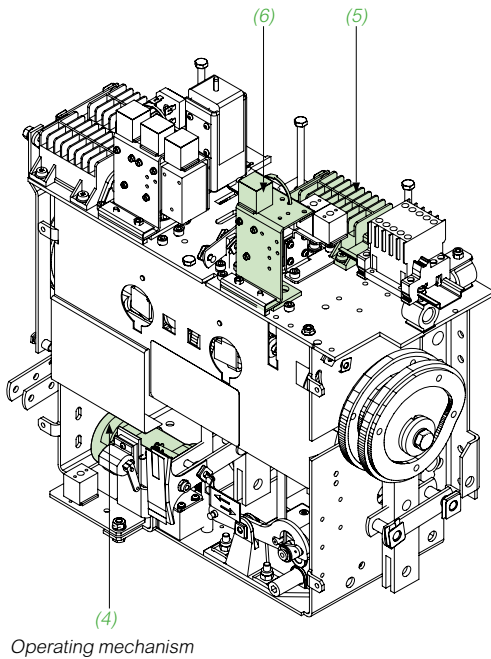

Operating mechanism (4)

DM103426

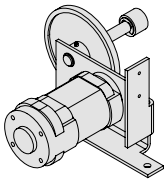

Charging motor M1 (4)

DM103423

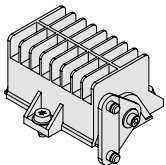

Auxiliary switch in charging position S2 (5)

DM103419

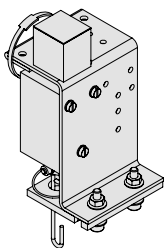

Auxiliary release F2 (6)

Function

Remote control enables remote opening and closing of the circuit breaker.

Composition

The remote control mechanism comprises:

- Charging motor M1
- Auxiliary switch in charging position S2
- Auxiliary release F2

Charging motor M1

The operation counter installed on the operating interface records the circuit breaker operating frequency.

Characteristics		
Power supply	V AC	110/220
	V DC	24/48/110/220
Threshold	V AC	0.85 to 1.1 Ur
	V DC	0.85 to 1.1 Ur
Consumption	V AC	approx. 100 W
	V DC	approx. 100 W

Operating time of coil and motor	
Duration of the minimum opening command	20 ms
Duration of the minimum closing command	20 ms
Motor charging time	4 ~ 12 s

Auxiliary switch in charging position S2

The auxiliary switch is mainly used to check and indicate the charging status.

It is connected by the charging mechanism to ensure that, during the closing operation, the driving mechanism can automatically store energy.

When charging is complete, it breaks the electrical charging circuit.

Generally speaking, the circuit breaker is equipped with an auxiliary switch with eight contact elements.

Auxiliary release F2

The auxiliary release coil is actuated by the auxiliary power supply.

The coil is designed for short-term operation only; its main circuit is therefore routed via an auxiliary switch contact controlled by the circuit breaker shaft, and upon release it interrupts the current circuit.

Characteristics		
Power supply	V AC	110/220
	V DC	24/48/110/220
Threshold	V AC	0.85 to 1.1 Ur
	V DC	0.85 to 1.1 Ur
Consumption	V AC	180 W
	V DC	180 W

HVX circuit breakers

Indication and locking/interlocking function

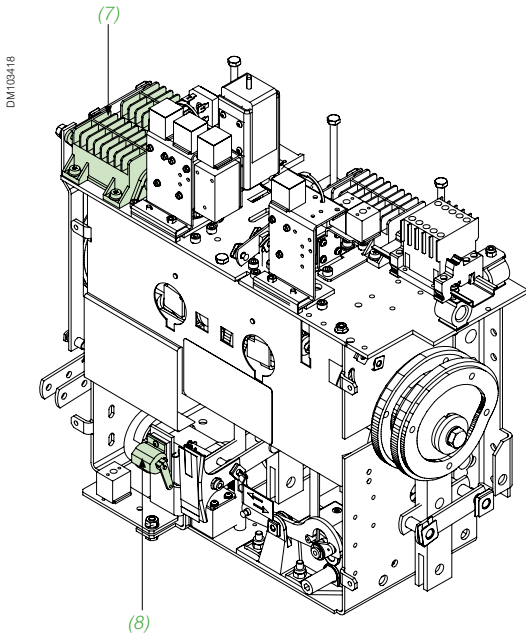

Operating mechanism

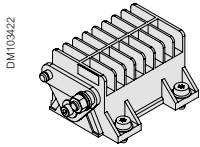

Auxiliary switch in switching position S11/S12/S13 (7)

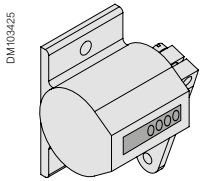

Operating counter (8)

“Open/closed” auxiliary contacts

The number of contacts available depends on the options chosen on the operating mechanism.

In the basic configuration, the circuit breaker's operating mechanism comprises a total of:

- 8 or 12 Normally Closed (NC) contacts
- 8 or 12 Normally Open (NO) contacts

Auxiliary switch in switching position S11/S12/S13

Auxiliary switches are always actuated directly by the switch shaft via an intermediate linkage, the position of which always corresponds to the position of the main contacts, indicating the breaker's on and off position status; during wiring, the interlock assists the release to prevent handling errors.

Generally speaking, the circuit breaker is equipped with two auxiliary switches with a total of eight contact elements.

Characteristics		DC			AC	
Rated voltage of auxiliary switch V		≤ 48	125	220	120	230
Breaking capacity	A	10	3.8	2	10	10
Time constant T=L/R	s	10	10	10	10	10
Rated short-circuit withstand current	A/3s	250	250	250	250	250
Rated current	A	15	15	15	15	15

Operation counter

The operation counter installed on the operating interface records the circuit breaker operating frequency.



HVX range

The HVX series vacuum circuit breaker is the result of Schneider Electric's years of technical experience in the medium-voltage field. The HVX series offers a proven state-of-the-art design with vacuum interrupters to meet the specifications for power switching devices in air-insulated switchgear. The HVX series circuit breaker is operated via a spring mechanism that provides an operating speed independent of the operator. When the operating mechanism is motorised the circuit breaker can include telecontrol functions and carry out rapid reclosing cycles.

Vacuum interrupter

The Schneider Electric VG series vacuum interrupter achieves the optimal design, thanks to the newest computer modeling tools. With the most advanced one-stop seal-off technology, the VG series minimizes artificial pollution in production. Based on our patented design and full knowledge of vacuum interrupter technology, Schneider Electric's vacuum interrupter stands out in the medium-voltage field with its high reliability, small size and long service life.

Operating principle of Vacuum interrupter

Vacuum interrupters basically have two electrical contacts (Fig. 1), one fixed and the other mobile, and a sealed enclosure. The sealed enclosure enables a high level of vacuum to be maintained inside the interrupter (less than 10⁻² Pa) to provide insulation between the open contacts.

The dielectric strength of the vacuum allows the contact-to-contact distance to be reduced. This short distance together with the low opening speed allow the use of a low energy control mechanism. A metal clusters provides the link between the mobile contact and the enclosure.

In order to keep the vacuum level required for the correct operation of the interrupter for 30 years, the enclosure must be perfectly sealed.

In vacuum breaking, the electrical arc generated on separation of the contacts is made up of a plasma of metal vapors produced by the vaporization of the contact material.

At low values of current, these vapors very quickly condense on the shield and contacts when the arc disappears, thus allowing:

- the vacuum to be re-established
- a contact-to-contact dielectric strength to be restored that is greater than the recovery voltage: breaking is then complete.

At high currents, the electrical arc in the vacuum switches to a concentrated mode which causes high, localized temperature rises on the contacts. The existence of these hot spots is detrimental to the quick restoring of the dielectric strength.

Two techniques can be used in order to avoid this stagnation of the static concentrated arc:

- the so called RMF (Radial Magnetic Field) technique, involves rotating the arc thanks to an electromagnetic effect generated by a radial magnetic field; this therefore limits contact erosion.
- a more recent technique called AMF (Axial Magnetic Field) involves applying an axial magnetic field parallel to the axis of the two contacts (Fig. 2) which allows a diffuse arc to be maintained (fig. 3) even at high current values. The arc energy is spread over the whole contact surface area, therefore causing very low levels of erosion.
- Schneider Electric has chosen this last technique for the HVX range.

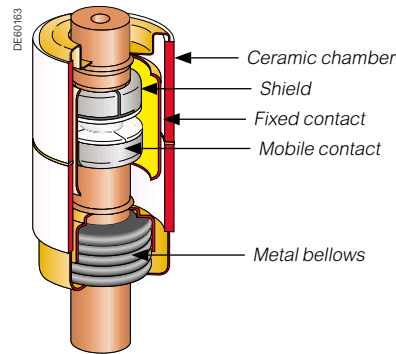

Fig. 1: vacuum interrupter components

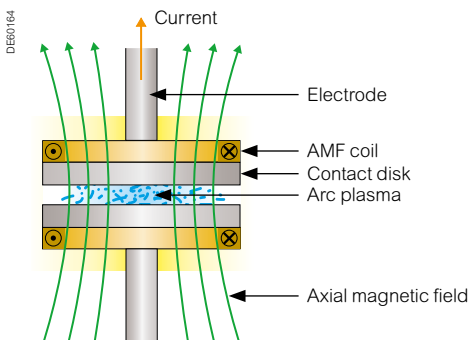

Fig. 2: cross-section of AMF contact

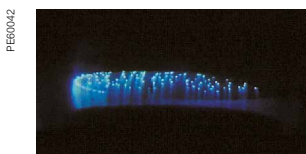

Fig. 3: diffuse vacuum arc AMF technology

PEE9213



VRF3

Voltage transformers

The voltage transformers supply:

- Measuring, metering and monitoring instruments
- Relays and safety devices.

They are installed in the cable connection compartment in the case of incomer/feeder cubicles and in the busbar compartment in the case of bus sectioning and bus riser cubicles.

The live parts of the dry-insulated voltage transformers are incorporated in a resin enclosure. The electrical and mechanical characteristics of these compact transformers help to protect them against fire hazards.

Fixed voltage transformers

F400 cubicles are fitted with fixed voltage transformers.

The three transformers are phase/earth type voltage transformers.

Schneider Electric fixed voltage transformer characteristics.

(For other supplier, please consult us).

For AD6, RD6, CL6/GL6, TT6, PT6 cubicles

Type of VT	Ratio			1st secondary winding (VA - class)	2nd secondary winding (VA - class)	Flow		
	Primary voltage	1st secondary winding voltage	2nd secondary winding voltage					
VRF3n/S2	20000 / $\sqrt{3}$	100 / $\sqrt{3}$	100 / 3	50-100 VA cl. 0.5	100 VA 3P	not simultaneous		
				150 VA cl. 1	100 VA 3P	not simultaneous		
			100 / $\sqrt{3}$	50 VA cl. 0.5	50 VA cl. 0.5/3P	simultaneous		
				75 VA cl. 1	75 VA cl. 1/3P	simultaneous		
			22000 / $\sqrt{3}$	110 / $\sqrt{3}$	110 / 3	50-100 VA cl. 0.5	100 VA 3P	not simultaneous
						150 VA cl. 1	100 VA 3P	not simultaneous
	110 / $\sqrt{3}$	50 VA cl. 0.5			50 VA cl. 0.5/3P	simultaneous		
		75 VA cl. 1			75 VA cl. 1/3P	simultaneous		
	30000 / $\sqrt{3}$	100 / $\sqrt{3}$	100 / 3	50-100 VA cl. 0.5	100 VA 3P	not simultaneous		
				150 VA cl. 1	100 VA 3P	not simultaneous		
			100 / $\sqrt{3}$	50 VA cl. 0.5	50 VA cl. 0.5/3P	simultaneous		
				75 VA cl. 1	75 VA cl. 1/3P	simultaneous		
			33000 / $\sqrt{3}$	110 / $\sqrt{3}$	110 / 3	50-100 VA cl. 0.5	100 VA 3P	not simultaneous
						150 VA cl. 1	100 VA 3P	not simultaneous
	110 / $\sqrt{3}$	50 VA cl. 0.5			50 VA cl. 0.5/3P	simultaneous		
		75 VA cl. 1			75 VA cl. 1/3P	simultaneous		
	35000 / $\sqrt{3}$	110 / $\sqrt{3}$	110 / 3	50-100 VA cl. 0.5	100 VA 3P	not simultaneous		
				150 VA cl. 1	100 VA 3P	not simultaneous		
110 / $\sqrt{3}$			50 VA cl. 0.5	50 VA cl. 0.5/3P	simultaneous			
			75 VA cl. 1	75 VA cl. 1/3P	simultaneous			



VRP4n

Rotary voltage transformers

F400 cubicles can be fitted with rotary voltage transformers. Please consult us. The 3-phase/earth voltage transformers are disconnectable devices. Each transformer is protected by a fuse incorporated in the transformer primary winding. They are operated simultaneously from the rear of the cubicle. When the voltage transformers are in the "isolated" position, the following operations can be performed with the cubicle powered on:

- A fuse can be replaced by opening a safety flap
- Transformers can be accessed by installing a padlockable separator.

For AD6, RD6, CL6/GL6, TT6, BM6 cubicles

Type of VT	Ratio			1st secondary winding (VA - class)	2nd secondary winding (VA - class)	Flow
	Primary voltage	1st secondary winding voltage	2nd secondary winding voltage			
VRP4n/S1	30000 / $\sqrt{3}$	100 / $\sqrt{3}$		50-100 VA cl. 0.5 150 VA cl. 1		
	33000 / $\sqrt{3}$	110 / $\sqrt{3}$		50-100 VA cl. 0.5 150 VA cl. 1		
	34500 / $\sqrt{3}$	115 / $\sqrt{3}$		50-100 VA cl. 0.5 150 VA cl. 1		
	35000 / $\sqrt{3}$	110 / $\sqrt{3}$		50-100 VA cl. 0.5 150 VA cl. 1		
VRP4n/S2	20000 / $\sqrt{3}$	100 / $\sqrt{3}$	100 / 3	50-100 VA cl. 0.5 150 VA cl. 1	100 VA 3P	not simultaneous
			100 / $\sqrt{3}$	50 VA cl. 0.5 75 VA cl. 1	50 VA cl. 0.5/3P 75 VA cl. 1/3P	simultaneous
	22000 / $\sqrt{3}$	110 / $\sqrt{3}$	110 / 3	50-100 VA cl. 0.5 150 VA cl. 1	100 VA 3P	not simultaneous
			110 / $\sqrt{3}$	50 VA cl. 0.5 75 VA cl. 1	50 VA cl. 0.5/3P 75 VA cl. 1/3P	simultaneous
	30000 / $\sqrt{3}$	100 / $\sqrt{3}$	100 / 3	50-100 VA cl. 0.5 150 VA cl. 1	100 VA 3P	not simultaneous
			100 / $\sqrt{3}$	50 VA cl. 0.5 75 VA cl. 1	50 VA cl. 0.5/3P 75 VA cl. 1/3P	simultaneous
	33000 / $\sqrt{3}$	110 / $\sqrt{3}$	110 / 3	50-100 VA cl. 0.5 150 VA cl. 1	100 VA 3P	not simultaneous
			110 / $\sqrt{3}$	50 VA cl. 0.5 75 VA cl. 1	50 VA cl. 0.5/3P 75 VA cl. 1/3P	simultaneous
	34500 / $\sqrt{3}$	115 / $\sqrt{3}$	115 / 3	50-100 VA cl. 0.5 150 VA cl. 1	100 VA 3P	not simultaneous
			115 / $\sqrt{3}$	50 VA cl. 0.5 75 VA cl. 1	50 VA cl. 0.5/3P 75 VA cl. 1/3P	simultaneous
	35000 / $\sqrt{3}$	110 / $\sqrt{3}$	110 / 3	50-100 VA cl. 0.5 150 VA cl. 1	100 VA 3P	not simultaneous
			110 / $\sqrt{3}$	50 VA cl. 0.5 75 VA cl. 1	50 VA cl. 0.5/3P 75 VA cl. 1/3P	simultaneous

PE55032



Functional current transformer

Functional current transformers

For AD6 type 1 and RD6 cubicles

F400 cubicles are fitted with functional current transformers. These transformers are integrated into the power bushings on which the fixed rack-in contacts are mounted. The current transformers have one, two or three 1 or 5 A secondary windings (1). The transformation ratios can be changed from the LV control cabinet.

Technical characteristics

Type	Ratio (A/A)	Measurement VA cl 0.5	Protection VA 5P20	Ith max					
				25 kA/1 s	25 kA/3 s	31.5 kA/1 s	31.5 kA/3 s	40 kA/1 s	40 kA/3 s
TCF4F/N2	50-100/5-5	10-20	5-10	■	■	■	■	■	
	100-200/5-5	15-30	5-10	■	■	■	■	■	
	200-400/5-5	15-30	5-10	■	■	■	■	■	
	300-600/5-5	15-30	5-10	■	■	■	■	■	■
	400-800/5-5	15-30	5-10	■	■	■	■	■	■
	600-1200/5-5	15-30	5-10	■	■	■	■	■	■
TCF4G/N2	1500/5-5	15	5	■	■	■	■	■	■
	2000/5-5	15	5	■	■	■	■	■	■
	2500/5-5	15	5	■	■	■	■	■	■

(1) For all other characteristics, please contact us.

PE98209



DIN current transformer

DIN current transformers

The F400 cubicles are fitted with DIN current transformers. The current transformers contain 1, 2 or 3 secondary windings rated at 1 to 5 A (1). The primary current values for conventional 1 A or 5 A current transformers are between 50 and 2500 A.

(1) For all other characteristics, please contact us.

For AD6, RD6, GL6, BM6 cubicles

Type	Ratio (A/A)	Measurement VA cl 0.5	Protection VA 5P20	Ith max					
				25 kA/1 s	25 kA/3 s	31.5 kA/1 s	31.5 kA/3 s	40 kA/1 s	40 kA/3 s
ARM9T/N2	50-100/5-5	10-20	5-10	■	■	■		■	
	100-200/5-5	15-30	5-10	■	■	■	■	■	
	200-400/5-5	15-30	5-10	■	■	■	■	■	
	300-600/5-5	15-30	5-10	■	■	■	■	■	■
	400-800/5-5	15-30	5-10	■	■	■	■	■	■
	600-1200/5-5	15-30	5-10	■	■	■	■	■	■
	1500/5-5	15	5	■	■	■	■	■	■
	2000/5-5	15	5	■	■	■	■	■	■
	2500/5-5	15	5	■	■	■	■	■	■

PE66210



ARL5 Toroid type current transformer

Low Voltage toroid type current transformers

For AD6, RD6 cubicles

F400 cubicles can be fitted with low voltage toroid type current transformers. F400 cubicles are fitted with LV toroid type current transformers when the installation requires additional secondary windings (>3).

AOPC, ARL4 and ARL5 toroid current transformers are installed in the cable compartment. The toroid accepts the secondary windings; the cable is the primary winding.

The transformers have a primary current of 50 to 2500 A and a secondary current of 1 to 5 A.

The type of AOPC, ARL4 and ARL5 current transformer selected depends on the number of medium voltage cables installed in the F400 cubicle.

Type of connection pads (for reference only)

Rated voltage	Rated current	Short-circuit current	Max. number of cables	Max. number of CTs
kV	A	kA	by phase ⁽¹⁾ size	by phase and type
12-36	1250/1600	31.5	2	2 x AOPC
12-36	2000	31.5	3	2 x ARL4
12-36	2500	31.5	4	2 x ARL5

(1) Cable section for size 3 connection pads: 150 to 630 mm².

PM108622



CSH toroid CT

Zero sequence core balance current transformers (CSH type)

For AD6, RD6 cubicles

CSH 120 and CSH 200 core balance CT's provide more sensitive protection by direct measuring of earth fault currents.

Specifically designed for the Sepam range, they can be directly connected to the Sepam "residual current" input.

They differ only in diameter:

- CSH 120 - 120 mm internal diameter
- CSH 200 - 200 mm internal diameter.

PE58211



TLP190 Low-Power Current Transformer
Phase current measurement range: 5-2500 A

LPCT Low-Power Current Transformer

TLP130 and TLP190 are low-power current transformers, current probe with voltage output conforming to IEC 60044-8 standard.

TLP130 and TLP190 current transformers in toroidal structure are designed to measure currents from 5 to 2500 A (1250 A for TLP130, 2500A for TLP190) using the 100 A/22.5 mV proportion, and can be used for different rated current values as they are installed on isolated cable. Sepam can be used with LPCT.

Benefits

- The same probe measures the phase currents between 5-2500 A
- Accuracy guarantee in the measurement range:
- Protection: class 5P for 5 A-40 kA
- Measurement: class 0.5 for 100-2500 A (0.75 for 20 A, 1.5 for 5 A).
- Easy installation:
- Secondary cabling ready for connection
- Easy connection on isolated cable in each cubicle type.
- Safe use:
- Secondary circuit trips under load.

PE58212



TLP130 Low-Power Current Transformer
Phase current measurement range: 5-1250 A

For AD6 cubicles

Technical characteristics	Type	
	TLP 130	TLP 190
Standard	IEC 60044-8	IEC 60044-8
Rated minimum primary current	5 A	5 A
Rated nominal primary current	100 A	100 A
Rated extended primary current	1250 A	2500 A
Rated secondary voltage	22.5 mV	22.5 mV
Measurement accuracy class	0.5	0.5
Protection accuracy class	5P	5P
Accuracy limit factor	250	400
Rated short-time current	25 kA/1s	40 kA/1s
Highest voltage for equipment	0.72 kV	0.72 kV
Rated power-frequency withstand voltage	3 kV	3 kV
Secondary plug	RJ45 - 8 points	RJ45 - 8 points
Inner Diameter	130 mm	190 mm

Easergy P5 is available in two sizes to best fit your needs



Easergy P5 protection relay is based on proven technology concepts and developed in close cooperation with customers, so it's built to meet your toughest demands:

- Modular design that allows user-defined conventional protection and arc-flash protection solutions
- Compatible with conventional CTs/VTs or low power instrument transformers LPCT/LPVT compliant to IEC 61869-10 and IEC 61869-11 standards
- Embeds latest cybersecurity functionality to help prevent intentional miss-use and cyber-threats
- Fast replacement with enhanced P5 safety thanks to withdrawability and back-up memory that automatically restore parameters without using any configuration tools

Easergy P5 is a family of digital protection relays for distribution networks dedicated to:

- **Utilities - Energy distribution**
- **Critical buildings and Industry**
 - Healthcare
 - Transportation
 - Industrial buildings
 - Data Center
- **Large industrial processes**
 - Oil and Gas
 - Mining
 - Mineral and Metals
 - Water

Easergy products are designed to be user friendly, a feature that is proven in our customer reports day after day. You'll benefit from features that include:

- A complete set of protection functions, related to the application
- Arc detection in Easergy P5x30 models
- Dedicated circuit breaker control with single-line diagram, push buttons, programmable function keys, LEDs, and customizable alarms
- Multilingual HMI for customized messaging
- Settings tool relay management software for setting parameters, configuring, and network fault simulation
- Both serial and Ethernet communication, including redundancy
- IEC 61850 standard Edition 1 & Edition 2

Range overview

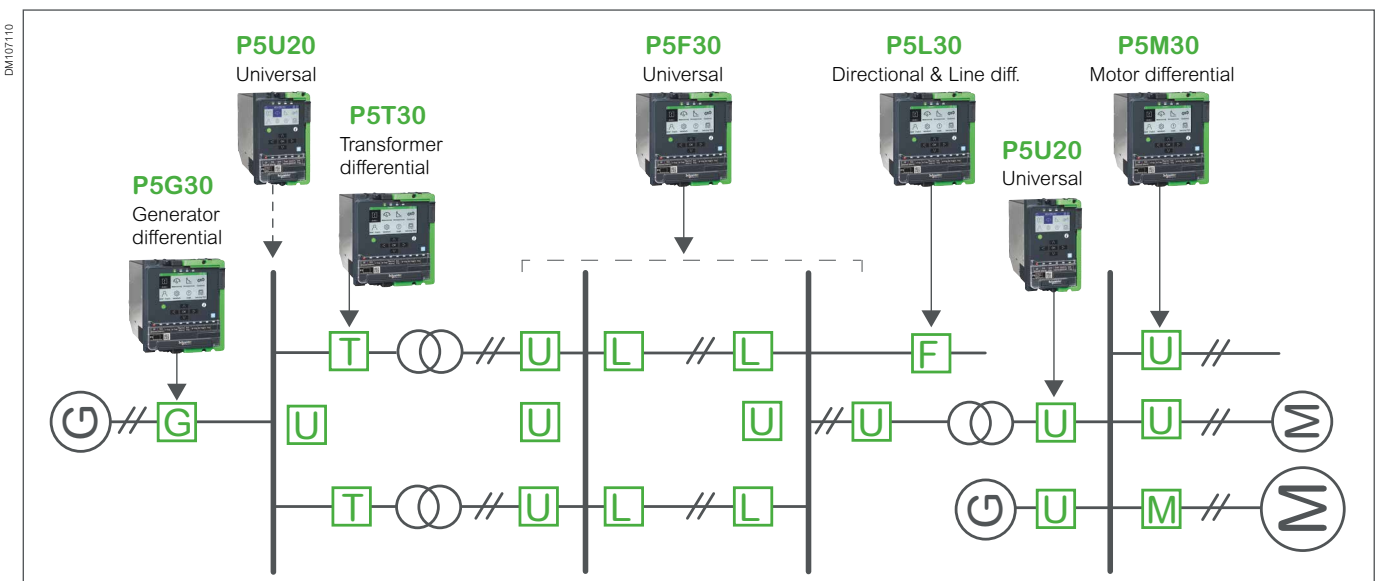

Easergy P3 standard Universal applications



P3U10/20/30 = Universal protection

- Feeder and Transformer
- Motor
- Voltage
- Frequency
- Capacitor

Easergy P3 advanced Advanced applications with arc flash fault detection



- **P3F30** Feeder and Transformer
- **P3M30** Motor
- **P3G30** Generator
- **P3L30** Line differential and Distance
- **P3T32** Transformer differential
- **P3M32** Motor differential
- **P3G32** Generator differential

Solid protection meets unparalleled efficiency

The Easergy P3 protection relay family is based on proven technology concepts developed in close cooperation with customers. Easergy products have been designed around user-friendliness, a feature which is proven in our customer feedback day after day.

The Easergy P3 feeder manager has been developed to cover basic protection needs for OEMs, utilities and industrial applications. Thanks to its cost-effective and flexible design, the Easergy P3 provides an excellent alternative for various protection applications.

Easergy P3 combines further protection functions such as directional earth fault for feeder and motor protection.

Unparalleled efficiency

- Simple selection and ordering with EcoReal MV
- Faster delivery with on-the-shelf availability of standard configurations
- Simplified configuration with the new eSetup Easergy Pro setting tool

Better Connectivity

- Simpler operation and maintenance with the Easergy P3 SmartApp
- All communication protocols included natively, including IEC 61850
- Possible to use two active communication protocols in the same time
- Increased number of inputs and outputs for more possibilities

Enhanced safety

- Embedded arc protection
- Built-in virtual injection testing
- Compliant to international standards (i.e. IEC 60255-1)

Ease of use

User-friendliness is a key benefit of Easergy P3, made to save time at every step of the project's life-cycle.

A great deal of effort has gone into designing the operational aspects of the new products. Setting and download/upload are much faster thanks to the unique eSetup Easergy Pro setting software which dramatically improves usability.

The informative human machine interface shows the information the user needs, with the support of customized legend texts.

Enhanced usability

The Easergy P3 protection relay concept has been extended with a number of features that make installation and testing of the relays even more efficient and user-friendly, like the virtual injection testing accessible with eSetup Easergy Pro setting software.



Each functional unit can be equipped with a comprehensive protection, monitoring and control system comprising:

- Instrument transformers to measure the necessary electrical values (phase current, residual current, voltages, etc.)
- Protection relays, providing functions adapted to the part of the network to be protected
- Metering equipment, to inform operators
- Low voltage relaying, to provide control of the breaking device and of the withdrawable part
- Various auxiliaries: secondary circuit test units, etc.

Easergy Sepam: protection digital relays

Easergy Sepam is a range of digital monitoring protection and control units.

Easergy Sepam is the centre of the protection, monitoring and control system functional units: all the necessary protection, metering, control, monitoring and signalling functions are carried out by Easergy Sepam.

The Easergy Sepam range is a range of units defined to provide an optimal solution for each application, and includes (e.g.):

- Easergy Sepam S, substation incomer and feeder
- Easergy Sepam B, bus sectioning
- Easergy Sepam T, transformer feeder
- Easergy Sepam M, motor feeder
- Easergy Sepam G, generator feeder
- Easergy Sepam C, capacitor feeder

The Easergy Sepam range consists of the Easergy Sepam series 20, series 40, series 60 and series 80, a range of modular protection relays to adapt precisely to your needs.

Protection chain

The Easergy Sepam protection units combined with innovative current sensors, provide a comprehensive measurement, protection and energy management chain.*

A high-performance, economical solution

The modular Easergy Sepam offer provides a cost-effective solution tailored to every requirement.

Easy to order and install

All the components of the protection chain are referenced and can be delivered very quickly.

The power of a multi-functional digital unit

Easergy Sepam is more than a simple protection relay; it is a truly multi-functional unit offering, in particular:

- Circuit-breaker diagnosis functions (switching counter and time, rearming time, cumulated broken A2)
- Direct circuit-breaker control, whatever the type of release unit
- Remote equipment operation using the communication option

(* Please check in the Sepam catalogue the sensor to use with each Sepam version.

PM108625



Easergy MiCOM protection relays

Easergy MiCOM protection provides the user with a choice of cost-optimised solutions for specific protection requirements within the distribution network.

The Easergy MiCOM relay series offers comprehensive protective function solutions for all power supply systems, as well as for the various functional and hardware project stages.

With their modular design, the Easergy MiCOM device platforms provide the user with multifunctional equipment that can act as:

- Grid protection equipment, and
- Combined protection and control systems
- Easergy MiCOM devices integrate most standard communication protocols used in station control systems and SCADA systems
- Due to the continuous further development of these products, compatibility with technical progress in the field of switchgear and controlgear communication is ensured

Easergy MiCOM offers varying levels of functionality and hardware

- **Series 30** is designed to meet the rigorous requirements of MV & HV applications with particular focus on feeder and transformer protection and control.
- **Series 40** fulfills the protection requirements for a wide market of utility and industrial systems and offers a complete range of protection functions.

Arc fault detectors selection guide



Functions

The arc protection unit detects an arc flash in an installation and trips the feeding breaker.

System features

- | | | |
|--|--|--|
| <ul style="list-style-type: none"> • Typical operation on light only principle <ul style="list-style-type: none"> - Input for current criteria for I> and L> operation - Integrated 19 - 256 V AC/DC aux. supply • Optimised for wind power and other small applications • Up to 4 arc sensors • Selective trip for 2 zones • Operation time 1 ms with high speed output and 8 ms with a trip relay • Non-volatile trip status • Self-supervision • Straightforward installation • Cost efficient solution | <ul style="list-style-type: none"> • Operation on light only • Up to 10 arc or smoke sensors • Single trip contact • Straightforward installation • Operation time 9 ms (including the output relay) • Cost efficient solution • Self-supervision • Binary input for blocking or resetting the unit (programmable) • Possibility for double arc channel activation trip criteria • BIO light transfer possibility to other Vamp device | <ul style="list-style-type: none"> • Flexible and modular system can be adapted to different targets requiring arc protection • Central unit and modular units engineer a scheme to your requirements • Continuous system self-supervision • 3-phase current zero sequence voltage and current • Event logs, disturbance recording and real-time clock • Operation on simultaneous current and light or on light only • Direct connection of arc sensors in the central unit without using I/O units • 7 ms operation time with trip contact and 2 ms with high speed output (HSO) • Programmable operation zones • Communication protocol support for SCADA and automation interfacing • Supports maximum 6 Digital Inputs and 8 Digital Outputs for object (CB) status and control (order option dependent) |
|--|--|--|

Sensors

Point sensor - surface

- Arc detection from two compartments simultaneously
- Self-monitored
- Cable length adjustable from 6 m to 20 m down

Point sensor - pipe

- Self-monitored
- Cable length adjustable from 6 m to 20 m down

Loop sensor

- Monitors various compartments
- Small bending radius for easy installation

Benefits

- Reduces production losses
- Extended switchgear life cycle
- Reduced insurance costs
- Low investment costs and fast installation
- Enhancing people safety

IEC standards	IEC standards	IEC standards
---------------	---------------	---------------

* I/O units: 4 references available (VAM 3L, VAM 10L/LD, VAM 12L/LD, VAM 4C/CD). The choice is to be made according to the needs to the type and number of sensors. Please contact us.

The arc protection unit detects an arc flash in an installation and trips the feeding breaker

An arc flash protection system minimizes material damage caused by arc faults.

Arc flash protection minimizes material damage to the installation in the most hazardous power system fault situations.

Minimized damage also means limited need for repair work and enables rapid restoration of the power supply.

Vamp arc flash range



Advantages

Help to people safety

The shorter the operating time of the arc flash protection unit, the smaller will be the damage caused by the arc fault and the shorter the possible power outage.

Extended switchgear life cycle

Arc protection unit increases the life-cycle expectancy of switchgear installations, so that decisions to invest in new switchgear installations can be postponed and money can be saved by re-Vamping existing switchgear systems.

Reduced insurance costs

The faster and better the protection system of a power installation, the more generous will be the insurance terms and costs.

Low investment costs and fast installation

A comprehensive arc protection system is characterized by low investment costs and fast installation and commissioning times. One successful operation of the arc flash protection units provides an immediate investment payoff.

Reliable Operation

Operation is based on the appearance of light or alternatively on the appearance of light and current from an external device. Immune to nuisance trippings due to dual tripping criteria; light & current.

Key benefits

- Battery free
- Wireless communications
- High performances
- In contact measuring point
- Easy installation
- Compact footprint
- Remote monitoring and alarming

Continuous Thermal Monitoring

The power connections in the Medium Voltage products are one of the most critical points of the substations especially for those made on site like:

- MV Cable connections

Loose and faulty connections cause an increase of resistance in localized points that will lead to thermal runaway until the complete failure of the connections.

Preventive maintenance can be complicated in severe operating conditions also due to limited accessibility and visibility of the contacts.

The continuous thermal monitoring is the most appropriate way to early detect a compromised connection.

Easergy TH110 Thermal Sensor

Easergy TH110 is part of the new generation of wireless smart sensors helping to ensure the continuous thermal monitoring of all the critical connections made on field allowing to:

- Prevent unscheduled downtimes
- Help increase operators and equipments safety
- Optimize and predictive maintenance

Thanks to its very **compact footprint** and its **wireless communication**, Easergy TH110 allows an easy and widespread installation in every possible critical points without impacting the performance of the MV Switchgears.

By using **Zigbee Green Power** communication protocol, Easergy TH110 help ensure a reliable and robust communication that can be used to create interoperable solutions evolving in the Industrial **Internet of Things** (IIoT) age.

Easergy TH110 is **Self-powered** by the network current and it can help ensure **high performances** providing accurate thermal monitoring being in **direct contact** with the measured point.



Easergy TH110

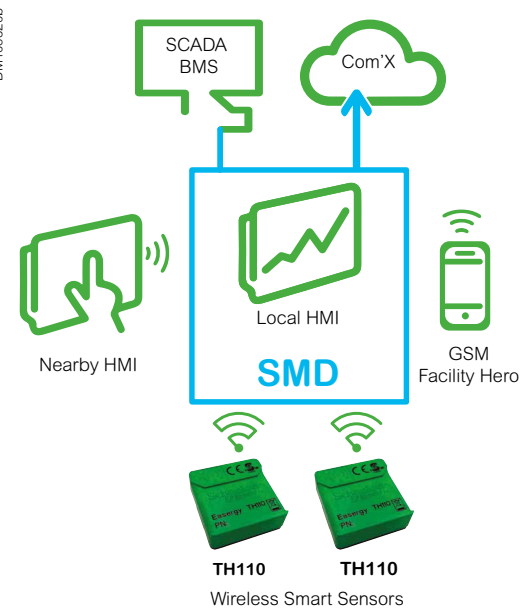

Substation Monitoring Device

Easergy TH110 is **connected** to the Substation Monitoring Device (SMD) that harvest the data for local signaling, data analyses and nearby control.

Specific **monitoring algorithms** allow to detect drifts from the threshold based on the specific installation characteristics also in regards of the variable loads or abnormal behaviors coming from phases comparison.

The **remote monitoring and alarming** help ensure full peace of mind thanks to remote connection for SCADA or Services, access to Cloud-based Apps and digital services and alarming through SMS or Facility Hero mobile App.

Characteristics

Power supply	Self-powered. Energy harvested from power circuit.
Minimum activation current	5 A
Accuracy	+/- 1°C
Range	-25 °C / +115°C
Wireless communication	ZigBee Green Power 2,4 GHz
Dimension - Weight	31 x 31 x 13 mm - 15 g

Protection, monitoring & control

Wireless Environmental Monitoring

Easergy CL110

Key benefits

- Long battery life expectation
- Wireless communications
- High performances
- In contact measuring point for temp.
- Easy installation with magnets
- Compact footprint
- Remote monitoring and alarming



Easergy CL110

Characteristics

Temperature Accuracy	+/- 1°C in a range from -25°C to 90°C
Relative Humidity Accuracy	2% in a range from 10% to 98%
Wireless Communication	ZigBee Green Power 2,4GHz
Protection degree	IP54
Dimension - weight	40x40x21 mm – 34g
Power supply	3V battery

Continuous Environmental Monitoring

Harsh environment due to pollution, condensation and strong temperature drifts is one of the most critical failure cause due to accelerated aging.

In **MV Switchgears** an harsh environment generate dirt that, on the surface of not shielded insulators, can lead to surface partial discharges up to a complete flashover.

In **LV compartments** an harsh environment can generate rust on metallic parts and electronic contacts.

The continuous environmental monitoring is the most appropriate way to early detect installation issues optimizing maintenance with predictive information.

Easergy CL110 Environmental Sensor

Easergy CL110 is part of the new generation of wireless smart sensors helping to ensure the continuous environmental condition monitoring allowing to perform, over a deenergized surface, the measurement of:

- Temperature of the surface in contact
- Relative humidity

By using algorithms, the above data can be computed to calculate the dew point and condensation occurrence.

Thanks to its **compact footprint** and its **wireless communication** Easergy CL110 allows an easy and widespread installation also providing IP54 degree of protection in indoor applications.

Easergy CL110 is **battery powered with life expectation >15 years** and it allows a simple fixing on magnetic metal surfaces thanks to its **high-strength magnets**.

By using **Zigbee Green Power** communication protocol, Easergy CL110 help ensure a reliable and robust communication that can be used to create interoperable solutions evolving in the **Industrial Internet of Things (IIoT)** age.

Easergy CL110 provides accurate temperature monitoring of the metal surface being in **direct contact** with it.

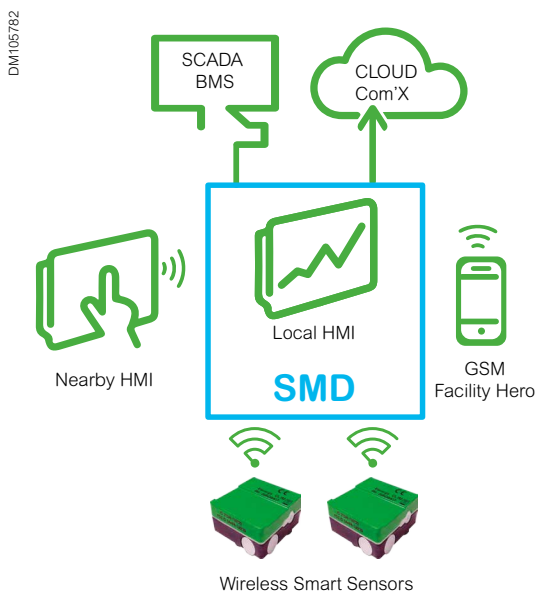

Substation Monitoring Device

Easergy CL110 is **connected** to the Substation Monitoring Device (SMD) that harvest the data for local signaling, data analyses and nearby display.

Specific **monitoring algorithms** allow to detect drifts from the threshold based on the specific installation characteristics.

The remote **monitoring and alarming** help ensure full peace of mind thanks to remote connection for SCADA or Services, access to Cloud-based Apps and digital services and alarming through SMS or Facility Hero mobile App.

Installation and connection

F400 connection	68
Implementation examples	69
Cubicle equipment	71
F400 36 kV	71
F400 40.5 kV	72

PMT09504



Switchgear resistance to ageing in a substation depends on three key factors

■ Correctly executed connections

New cold-connecting technologies facilitate installation and improve durability over time. They are designed for use in polluted environments with harsh weather conditions.

■ Impact of relative humidity

It is essential to install a heating element in climates with high relative humidity and wide temperature differentials.

■ Ventilation control

The dimensions of the air vents must be appropriate for the energy dissipated in the substation. They must sweep only the transformer environment.

The end-pieces are cold-connectable

Schneider Electric's experience has led it to favour this technology wherever possible for optimum durability over time.

The maximum permissible cable cross-sections for standard assembly are:

■ 1200 mm² for incomer or feeder cubicles with single-pole cables

■ 400 mm² for incomer or feeder cubicles with three-pole cables

■ The diameter of the cables must be ≤ 95 mm.

Access to the compartment is only possible when the earthing switch is closed.

Dry single-pole cable

Short cold-connectable end-piece	
Performance	7.2 to 36 kV
Cross section mm ²	240 mm ² XLPE for copper / 630 mm ² XLPE for aluminium
Supplier	All suppliers of cold-connectable terminals: Silec, 3M, Pirelli, Raychem, etc.
Number of cables	1 to 4 per phase
Comments	For larger cross sections and more cables, please contact us

Dry three-pole cable

Short cold-connectable end-piece	
Performance	7.2 to 36 kV
Cross-section mm ²	240 mm ² XLPE for copper and aluminium
Supplier	All suppliers of cold-connectable terminals: Silec, 3M, Pirelli, Raychem, etc.
Number of cables	1 to 4 per phase
Comments	For larger cross sections and more cables, please contact us

Connection possibilities using dry cables

Number of cables	AD6
1 single-pole/phase	■ (1) (4)
2 single-pole/phase	■ (1) (5)
3 single-pole/phase	■ (2)
4 single-pole/phase	■ (3)
1 three-pole/cubicle	■
2 three-pole/cubicle	■
3 three-pole/cubicle	■
4 three-pole/cubicle	■

(1) Possibility of installing AOPC LV toroid type current transformers

(2) Possibility of installing ARL4 LV toroid type current transformers

(3) Possibility of installing ARL5 LV toroid type current transformers

(4) Possibility of installing TLP130 Low-Power Current Transformers

(5) Possibility of installing TLP190 Low-Power Current Transformers.

Line-up switchboard with internal arc cubicle

- 1 AD6 - Incomer (with or without voltage transformers)
- 2 AD6 - Feeder (with or without voltage transformers)
- 3 CL6 - Bus sectioning (with or without voltage transformers)
- 4 GL6 - Bus riser (with or without voltage transformers).

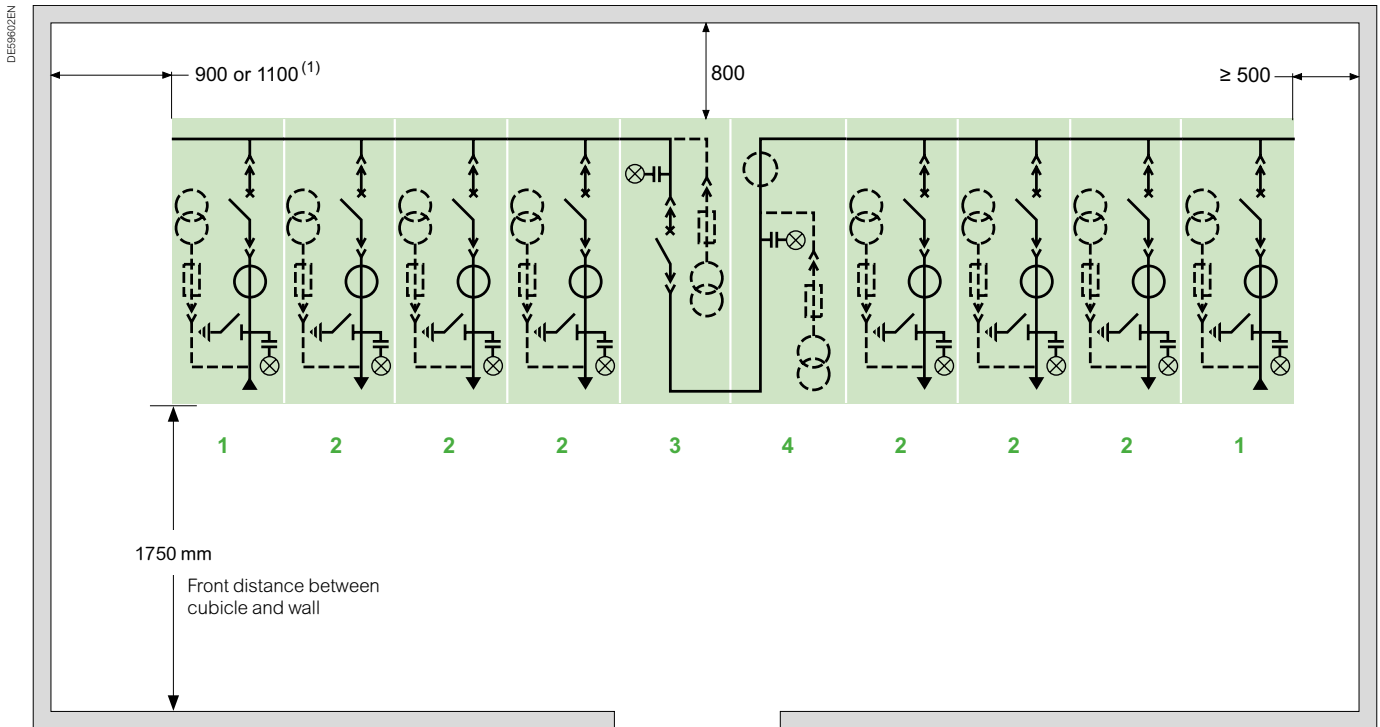

(1) Depending on the width of the first cubicle on the left of the switchboard.
Note: the switchboard is aligned on the front panel and all the cubicles have the same depth.

“Duplex” distribution

“Duplex” distribution can be implemented in these ways:

- Interconnection by means of cables
- Interconnection by means of insulated busbars (on request)
- Interconnection by means of busbars in a tunnel.

1 Incomer (with or without voltage transformers)

2 Feeder (with or without voltage transformers)

3 Transversal bus sectioning with a busbar or cable system and a disconnector unit (represented by the dotted line).

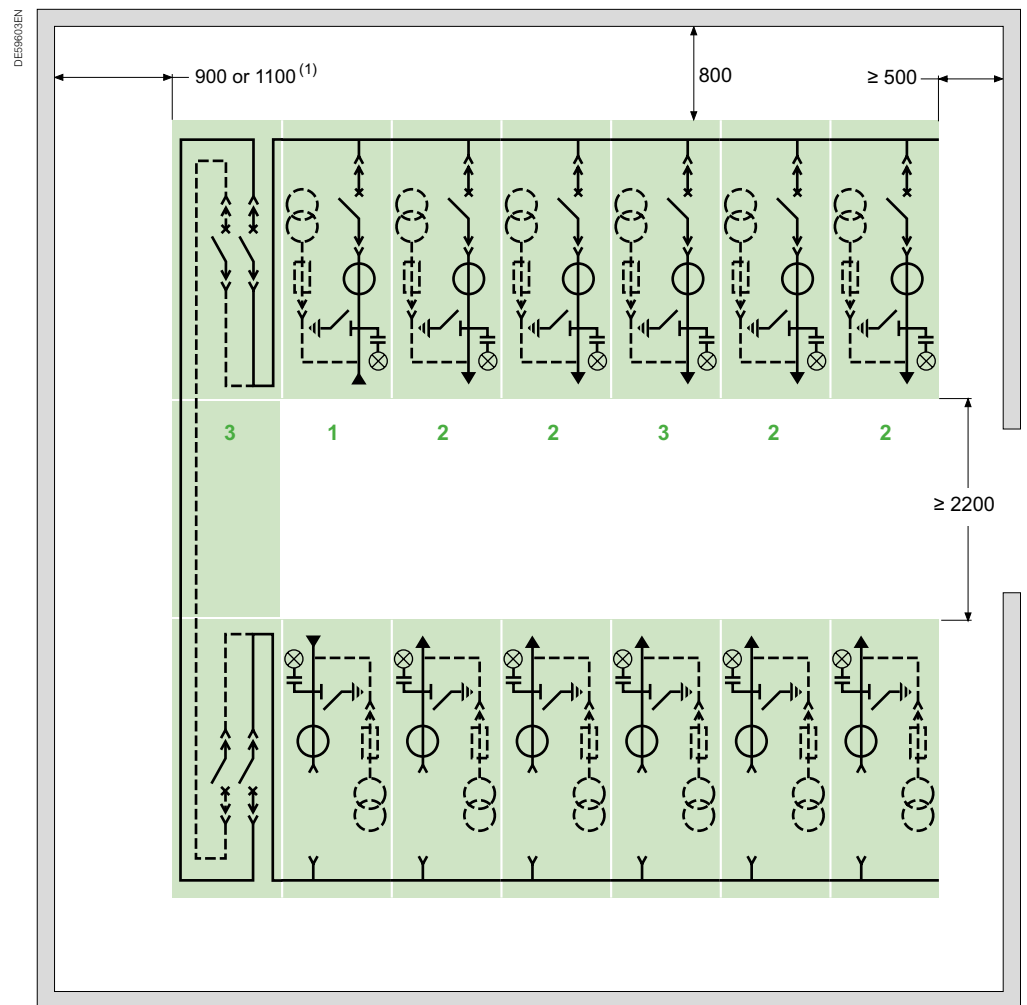

(1) Depending on the width of the first cubicle on the left of the switchboard.

Interconnections by means of cables

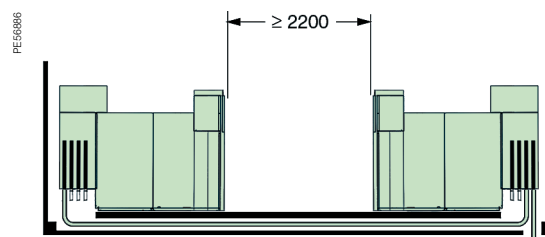

Equipment	Cubicle types									
	AD6 type 1	AD6 type 2	RD6	FD6	AL6	CL6	GL6	TT6	PT6	BM6
Switchgear										
SF or Vacuum circuit-breaker	■	■				■				
Single-threshold pressure switch	■	■				■				
Dual-threshold pressure switch	□	□				□				
Circuit-breaker control disabling	□	□				□				
Disconnecter truck	□	□				□				
Earthing truck	□	□				□				
Fuse truck				■					■	
Fixed busbar			■		■		■	■		■
Racking position indication contact for the withdrawable part (4NO + 4NC)	■	■				■				
Protective shutter padlocking	□	□		□		□			□	
Withdrawable part rack-in padlocking	□	□		□		□				
Withdrawable part rack-in locking by means of a keylock or electromagnetic device	□	□				□				
Circuit-breaker compartment key locking	□	□	□	□	□	□	□	□	□	□
Earthing switch (SMALT)										
Earthing switch	■	■	□	■				□		
Earthing switch position indication contact (3NO + 3NC)	□	□	□ (1)	□				□ (1)		
Earthing switch position key locking	□	□	□ (1)	□				□ (1)		
Electromagnetic locking of the earthing switch position	□	□	□ (1)	□				□ (1)		
Voltage transformers										
None	■	■	■	■	■	■	■	■		■
Rotative type (2)	□	□	□			□	□	□		□
Fixed type	□	□	□			□	□	□	■	
Current transformers										
None	□	□	□	■	■	■	■	■	■	
Functional (1 to 3 secondary windings)	■		■							
DIN format	□ (3)	■	□ (3)				□			■
Low voltage toroid type on cables	□	□	□							
LPCT on cables	□	□	□							
Zero sequence core balance CSH	□	□	□							
Cubicle										
Voltage presence indicator	■	■	■	■	■	■	■	■		■
Degree of protection of the enclosure IP3X (4)	■	■	■	■	■	■	■	■	■	■
Degree of protection between compartments IP2X	■	■	■	■	■	■	■	■	■	■
Anti-arcing protection		■	□	■	■	□	□	□	■	□
		□	□			□	□	□		□
		□	□			□	□	□		□
Lightning arrester	□	□	□		□			□		
Anti-condensation resistance (cable compartment and busbar)	■	■	■	■	■	■	■	■	■	■
LV control cabinet										
Keyless LV control cabinet locking	□	□	□	□	□	□	□	□	□	□
LV control cabinet lighting	□	□	□	□	□	□	□	□	□	□
Busbar										
1250 A or 2500 A exposed	■	■	■	■	■	■	■	■	■	■
1250 A or 2500 A insulated	□	□	□	□	□	□	□	□	□	□
Connection										
Cable connection from the bottom, 1 to 4 single-pole	■	■	■	■	■					
Cable connection from the bottom, 1 to 4 three-pole	■	■	■	■	■					
Cable connection from the top (on request)	□	□	□	□	□					
Busbar connection from the top (on request)	□	□	□	□	□					

(1) With earthing switch option

(2) Integrated fuse. For AD6 Type 2, rotative VT is available only with 2724mm depth version

(3) Additional DIN format is available

(4) For IP4X and IPX1, please consult us

(5) For SF6 circuit-breakers only

■ : Standard equipment

□ : Option.

Equipment	Cubicle types				
	AD6 type 1	RD6	CL6	GL6	TT6
Switchgear					
SF1 or SF2 circuit-breaker	■		■		
Single-threshold pressure switch	■		■		
Dual-threshold pressure switch	□		□		
Circuit-breaker control disabling	□		□		
Disconnecter truck	□		□		
Earthing truck	□		□		
Fixed busbar		■		■	■
Racking position indication contact for the withdrawable part (4NO + 4NC)	■		■		
Protective shutter padlocking	□		□		
Withdrawable part rack-in padlocking	□		□		
Withdrawable part rack-in locking by means of a keylock or electromagnetic device	□		□		
Circuit-breaker compartment key locking	□	□	□	□	□
Earthing switch (SMALT)					
Earthing switch	■	□			□
Earthing switch position indication contact (3NO + 3NC)	□	□ (1)			□ (1)
Earthing switch position key locking	□	□ (1)			□ (1)
Electromagnetic locking of the earthing switch position	□	□ (1)			□ (1)
Voltage transformers					
None	■	■	■	■	■
Rotative type (2)	□	□	□	□	□
Fixed type	□	□	□	□	□
Current transformers					
None	□	□	■	■	■
Functional (1 to 3 secondary windings)	■	■			
DIN format	□ (3)	□ (3)		□	
Low voltage toroid type on cables	□	□			
LPCT on cables					
Zero sequence core balance CSH	□	□			
Cubicle					
Voltage presence indicator	■	□	□	□	□
Degree of protection of the enclosure IP3X (4)	■	■	■	■	■
Degree of protection between compartments IP2X	■	■	■	■	■
Anti-arcing protection					
		25 kA - 1 s	□	□	□
		31.5 kA - 0.5 s	□	□	□
Lightning arrester	□	□			□
Anti-condensation resistance (cable compartment and busbar)	■	■	■	■	■
LV control cabinet					
Keyless LV control cabinet locking	□	□	□	□	□
LV control cabinet lighting	□	□	□	□	□
Busbar					
1250 A insulated	■	■	■	■	■
Connection					
Cable connection from the bottom, 1 to 4 single-pole	■	■			
Cable connection from the bottom, 1 to 4 three-pole	■	■			
Cable connection from the top (on request)	□	□			
Busbar connection from the top (on request)	□	□			

(1) With earthing switch option

(2) Integrated fuse. For AD6 Type 2, rotative VT is available only with 2724mm depth version

(3) Additional DIN format is available

(4) For IP4X and IPX1, please consult us

■ : Standard equipment

□ : Option.

Schneider Electric Industries SAS

35 rue Joseph Monier
92500 Rueil-Malmaison, France
Tel : +33 (0)1 41 29 70 00

www.schneider-electric.com

05, March, 2020

AMTED399053EN

©2020 Schneider Electric SE. All Rights Reserved.

All Schneider Electric trademarks and service marks are the property of Schneider Electric SE, its subsidiaries and affiliated companies.