

2018 Catalog



GHA

Gas-insulated switchgear up to 40.5 kV
Single and Double busbar
IEC | ANSI | RAIL

Medium Voltage Distribution

Contents

Overview	4
<hr/>	
GHA range	24
<hr/>	
GHA IEC single busbar	40
<hr/>	
GHA IEC double busbar	50
<hr/>	
GHA Rail	62
<hr/>	
GHA ANSI	72
<hr/>	
Components	82
<hr/>	
Installation and connection	100
<hr/>	

Your requirements



User experience



Service continuity



Peace of mind



Extended boundaries

Our solutions

- Arc resistant AFLR , up to 40kA 1s
- Mechanical and electrical interlocks, to prevent incorrect operations
- Touch proof design, all accessible parts grounded
- No maintenance on main circuit, risk reduced for maintenance crew
- Front cable testing and automatic cable grounding through circuit breaker

- All live parts insulated:
 - maintenance free
 - arc fault mitigation
 - extreme environmental conditions
- Permanent monitoring of insulation
- Record cell replacement time

- Arrives on site ready to connect
- No gas-handling along lifetime of the switchgear under normal operations (installation, commissioning, operations, extension, replacement)
- Schneider electric supervision of installation

- Tested for harsh environment
- Suitable for seismic zones (seismic and vibrations tested)
- Options for high altitude, underground or low temperature applications
- Compact top entry design for installation in buildings

GHA, reach the unreachable



Attaining high performance has never been so easy

Tradition and innovation: Schneider Electric has been developing and manufacturing primary gas insulated switchgear for more than 30 years, with an installed base higher than 120 000 cubicles. Based on this experience, the GHA provides high performance level with optimized design.



Efficient - Reliable

While keeping the capital and operational expenditures at its lowest, GHA satisfies the most stringent customer requirements in terms of compactness, performances and power availability. GHA is ready for the IoT, as it can be easily integrated in the Smart Grid, and provides flexible options for remote monitoring.

- **Arc resistance is not an option.** All our cubicles are Internal Arc compliant to IAC AFL 1s. as standard.
- **Efficiency pushed to the edge** with compact design to optimize room dimensions
- **Reliability is our Benchmark:** Clear operating interface, embeded mechanical interlocks & disconnectable VT's on busbar and line side.



Overview

Overview

Fields of application	10
User experience	11
Efficient	13
Reliable	15
EcoStruxure Ready Solutions	16
Protecting the environment	21
Quality assurance	22
Schneider Electric Services	23

GHA is the optimum solution for switching substations and transformer substations up to 40.5 kV

GHA gas-insulated switchgear and control gear with vacuum circuit-breaker has been designed for the various operating requirements in public and industrial medium-voltage distribution systems.

Fields of application

Power supply companies

- Transformer substations
- Switching substations
- Consumer substations
- Distributed power generation

Industry

- Oil and gas industry
- Chemical industry
- Automotive industry
- Metallurgy
- Process engineering

Infrastructure

- Airports
- Railway stations and traction power supply systems
- Tower blocks
- Open-cast mining and deep mining

Wind power and photovoltaics

- Wind turbines (on shore and offshore)
- Solar power stations
- Network supply substations
- Power transformer substations

PM106266



PM106267



PM106268



PM106269





Protecting your assets

- Maximum protection against accidental contact due to complete metal enclosure of all switchgear components
- Control, monitoring and complete automation of the switchgear from a remote control room and/or a central control station. The staff need not access the switchgear room, for example, for switching and monitoring processes during normal operation.
- The switchgear cubicle can only be operated with the enclosure closed and the operator facing the front
- As protection against operating errors, the GHA features a logically designed, continuous mechanical and electrical interlock system
- Capacitive voltage testing system for zero voltage verification
- Voltage test of the high-voltage cables via the switchgear front
- GHA has been tested for the internal arc classification IAC in accordance with IEC/EN 62271-200, taking the actual short-circuit currents into account, both with earthed neutral and in isolated medium-voltage distribution systems

High operating reliability

- The live high-voltage components are located in hermetically enclosed, gas-filled compartments. The high-voltage components are designed for a constant, ideal climate during their entire service lives. Thus, they are insensitive to
 - Dirt and dust
 - Moisture
 - Vermin
 - Harsh atmospheres
- All high-voltage components outside of the gas-filled compartment are
 - Single-pole
 - Potential-controlled and externally grounded
 - Fully shrouded
 - Free from external ambient influences such as dust, moisture and vermin.
- IP 65 protection of the gas-filled compartments with live components
- The rugged, reliable insulating gas system ensures a constant dielectric status during the switchgear's entire service life
- The term "sealed pressure system" in relation to the GHA means:
 - No inspection and no replenishing of the insulating gas required over the entire service life
 - Internal insulating gas in the gas-filled compartments prevents contact oxidation and provides protection against any switchgear fires
- Straightforward and robust drive mechanism
- Potential dielectric sources of danger are avoided, for example by the following design measures:
 - The current transformers are not subject to dielectric stress due to high voltage
 - The single-pole, isolated, inductive voltage transformers are arranged outside the gas-filled compartments within the internal-arc-tested cable connection compartment
 - No need to remove switchgear and control gear components during high-voltage tests of the switchgear and control gear and the cables (voltage transformer with disconnecting device)

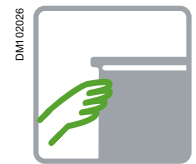

Improper contact



Vermin



Solar radiation



Dirt and dust



Harsh gas atmospheres

DWM 102026

Safe

Occupational health and safety management

The Occupational Health and Safety Management system for the development, production, distribution and servicing of GHA has been certified based on OHSAS 18001:2007.

We are committed to health

In line with our principles, Schneider Electric has undertaken to promote a program for maintaining good health which combines responsibility with economic efficiency.

- We cannot accept any risks regarding the health of our staff at work
- As a company, we would like to assume a model role regarding in-house protection of occupational health and safety
- Each area of the company strives to continuously improve in-house occupational health and safety by introducing a protection program
- Our company policy and improvements are defined uniformly worldwide, transformed into a local context and implemented
- All our members of staff and business associates must benefit from maximum adherence to occupational health and safety standards

These goals are secured over the long term, verified and continuously improved by a certified environmental management system for development, production, sales and service.

Efficient

Optimum design along whole life cycle

DM102-102

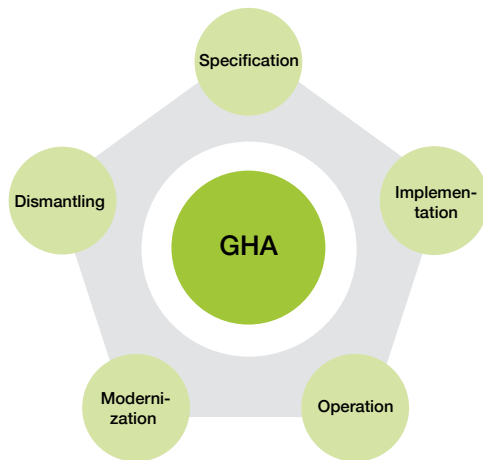

Schneider Electric Service is at your side during the switchgear's entire service life

Specification

We support you in the detailed definition of your projects: selection and project engineering lists, pressure calculations for the switchgear room, technical support, consultation.

Implementation

We implement and monitor local assembly and commissioning of your switchgear: design, cost optimization, guaranteed performance and reliability, commissioning, tests.

Operation

We support safe operation of your switchgear: maintenance agreement, technical support, provision of spare parts, troubleshooting and preventive maintenance, training for operation and maintenance.

Modernization

We keep your switchgear functions up to date: Inspection, diagnostics, adaptation, modification, expansion

Dismantling

We dismantle your complete switchgear at the end of its service life: disassembly, material data sheets, environmentally-compatible recycling.

DM102-103

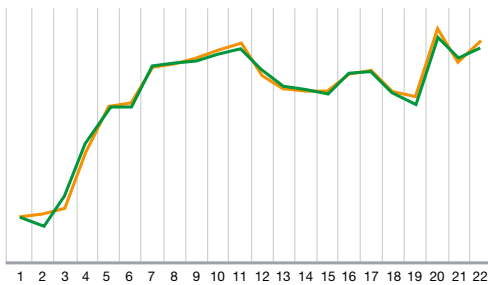

Measuring points
 — Measured temperature development
 — Simulated temperature development

Temperature development in switchgear cubicle

Optimum design thanks to simulation

Comprehensive computer-assisted simulations support the design process and the construction of GHA.

For determination of the best detailed design solution

- The temperature curves in the GHA switchgear and control gear are simulated comprehensively using the Thermal Network Analysis (TNA) process
- The dielectric fields are calculated and optimized using computerized models,
- The dynamic pressure development in the gas-insulated compartments is calculated
- The pressure relief equipment is located outside the switchgear cubicles

The computerized simulations and calculations correspond closely to the specific results of the type tests on the real objects.

The pressure load of the switchgear room in the event of internal arc faults and the determination of the necessary pressure relief devices can also be defined by Schneider Electric via simulation and calculation software.

PM103.073

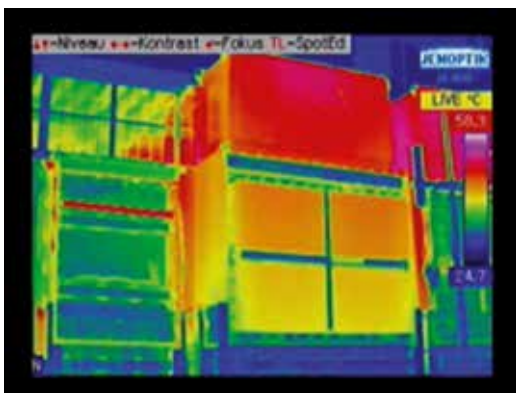

Thermography 2500 A switchgear cubicle

Reliable

Best in class ergonomics - Systematic Testing

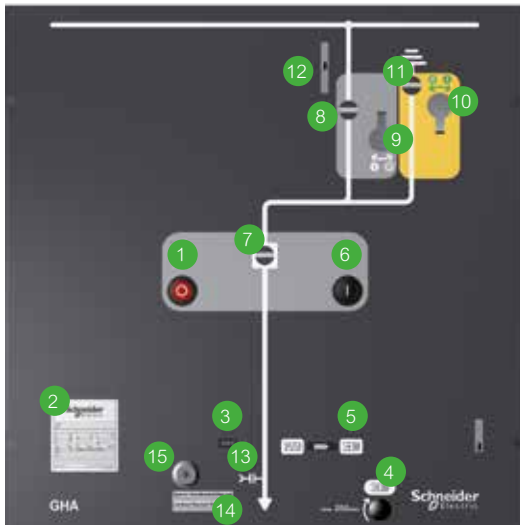

SBB operator interface

- 1 Pushbutton circuit-breaker OFF
- 2 Nameplate
- 3 Circuit-breaker operations counter
- 4 Insertion opening for charging the circuit-breaker's spring mechanism manually
- 5 Status indicator for spring mechanism released/charged
- 6 Pushbutton circuit-breaker ON
- 7 Switch position indicator, circuit-breaker
- 8 Switch position indicator, disconnecter
- 9 Insertion opening for operation of the disconnecter
- 10 Insertion opening for operation of the earthing switch
- 11 Earthing switch position indicator
- 12 Interrogation slide, disconnecter and earthing switches
- 13 Symbol for capacitive interface
- 14 Information sign
- 15 Mechanical lock-out with cylinder lock

Straightforward

- The architecture of the GHA switchgear cubicles and the arrangement of their components
 - Is very clear
 - Minimizes project handling costs and times
 - Ensures straightforward handling during set-up on site and problem-free cable connection
 - Facilitates operation
 - Ensures uncomplicated operation
 - Permits good accessibility
 - Offers step-by-step expansion and simple extension options
- "Intuitive operation" is our hallmark:
 - Optically enhanced mechanical control panel on each GHA switchgear cubicle
 - Logical arrangement of control elements and switch position indicators within the clearly arranged mimic diagram
 - Ergonomic operating levels both regarding the mechanical control panels and the digital bay computers
 - All control elements and indicators in the control panel are mechanical, i. e. independent of the auxiliary supply
 - Integrated mechanical panel interlocks (optional in case of digital bay computers or remote control of all switching devices)

PM103-152



Integral routine leakage test

Type tested

The electrical and mechanical ratings of the GHA switchgear and control gear have been proven successfully by comprehensive type tests.

The type tests were performed in independent and accredited test laboratories in accordance with international norms and standards. The results are recorded in the appropriate test records and are made available on request.

Consistent and systematic checks

Each GHA functional unit undergoes a systematic routine test during production to verify conformity with the relevant norms and standards and the specified quality. To this effect, the leak tightness of the panels is checked by an integral leakage test in order to satisfy maximum quality criteria.

The results achieved are documented and confirmed by the Quality Assurance Department in the form of a routine test record. This ensures traceability at the place of manufacture.

EcoStruxure™ ready solutions

What is EcoStruxure™?

450 000

EcoStruxure™ systems deployed since 2007 with the support of our 9 000 system integrators.

EcoStruxure™ ready



Efficient asset management
Greater efficiency with **predictive** maintenance helping to reduce downtime.



24/7 connectivity
Real-time data **everywhere anytime** to make better informed decisions.



Increase uptime
Proven design and experience combined with fast **embedded arc detection** for assets protection.

EcoStruxure™ architecture and interoperable technology platform bring together energy, automation, and software. It provides enhanced value around safety, reliability, efficiency, sustainability, and connectivity.

Turn data into action

EcoStruxure™ architecture lets customers maximize the value of data. Specifically, it helps them:

- Translate data into actionable intelligence and better business decisions
- Take informed decisions to secure uptime & operational efficiency thanks to realtime control platforms
- Get visibility to their electrical distribution by measuring, collecting, aggregating and communicating data

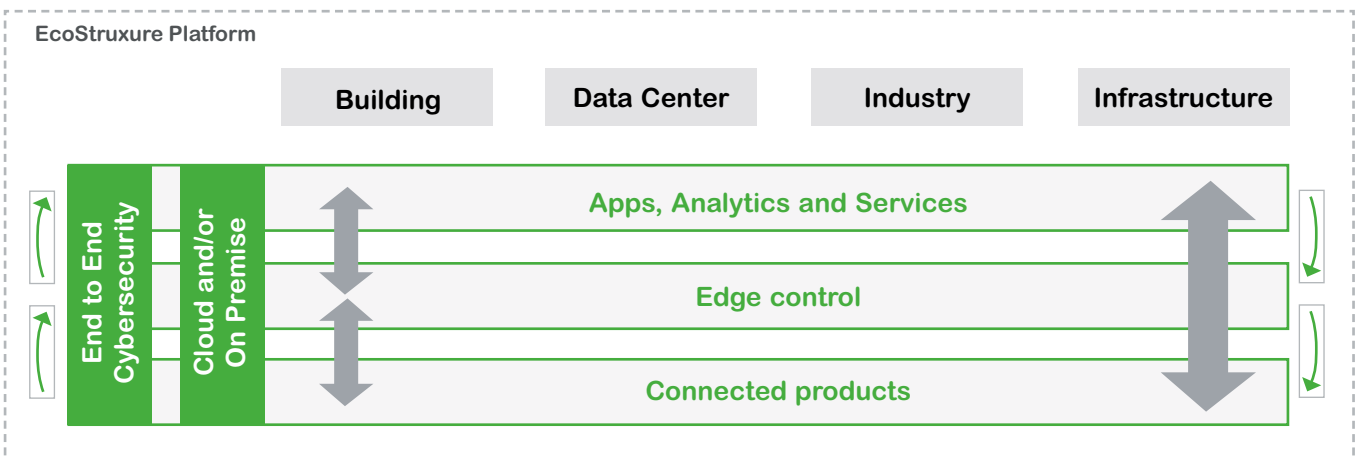
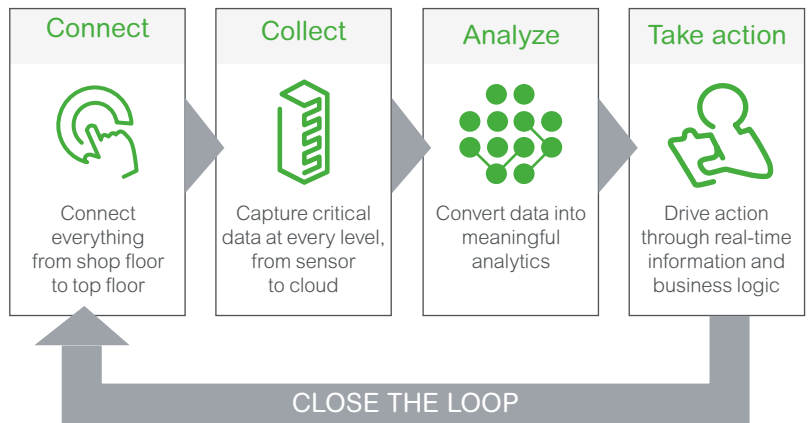

EcoStruxure™ Building EcoStruxure™ Power EcoStruxure™ IT EcoStruxure™ Machine EcoStruxure™ Plant EcoStruxure™ Grid

EcoStructure™ ready solutions

Core technologies for embedded connectivity and intelligence

Enable nearby control, ensure uptime

All the Schneider protection, metering and control devices can be connected to our Substation monitoring device.

The HMI can be installed anywhere within the substation to allow local control and monitoring, independent of any external systems.

The monitoring information and control functions can be scaled to the needs of each customer.

Optionally the Magelis control and monitoring functions can be mirrored on a tablet through Wifi connection thanks to our Vijeo Design Air application. The technician can operate at a safe distance the switchgear, while keeping visual contact with it.

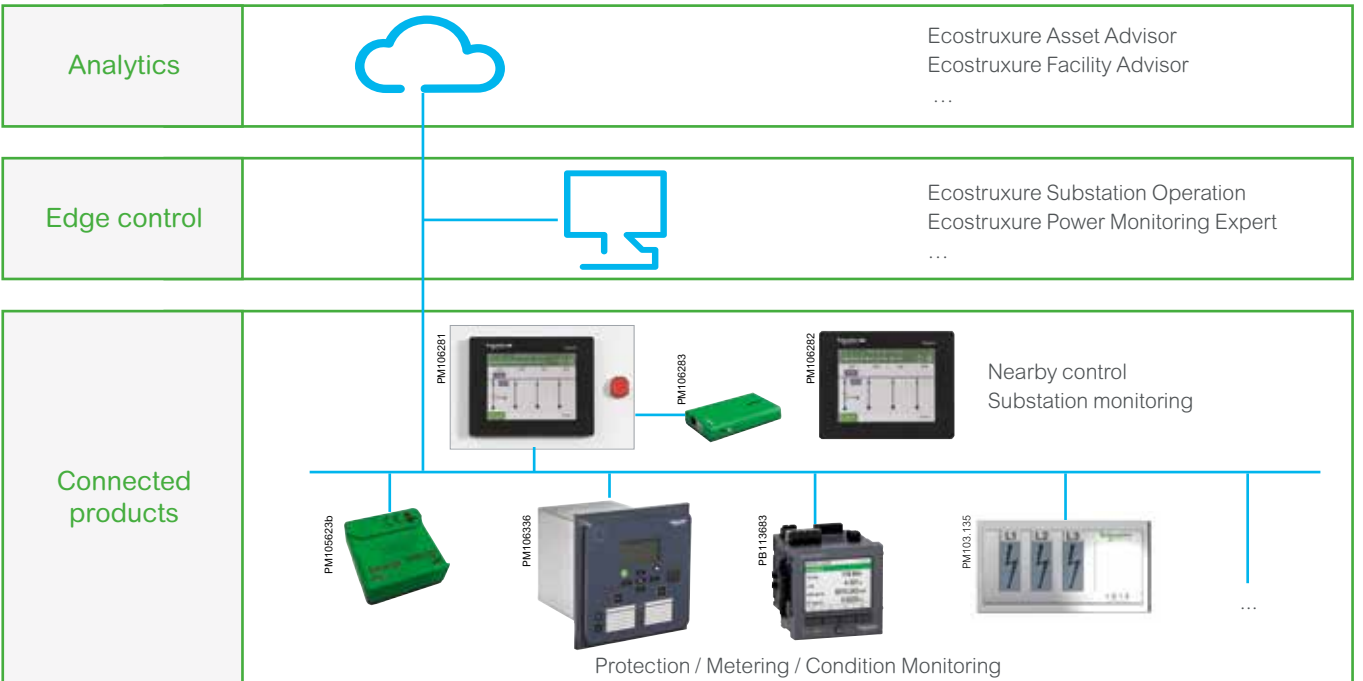

Easergy P3

Easergy P3 feeder manager has been developed to cover standard protection needs for industrial and commercial building applications. Thanks to its cost-effective and flexible design, Easergy P3 provides an excellent alternative for various protection applications.

User-friendliness has always been a value of Schneider Electric products, and the Easergy P3 is not an exception, with the unique possibility to operate through your smartphone or tablet with "Easergy SmartApp".

The rapid setting is achieved with the unique "eSetup Easergy Pro" setting software which dramatically improves usability.

Easergy P3Ux0 Standard applications



I & U



P3U10/20/30 = Universal protection

- Feeder and Transformer
- Motor
- Voltage
- Frequency
- Capacitor

Easergy P3x3x Advanced applications with arc fault mitigation



I & U



- **P3F30** Feeder and Transformer
- **P3M30** Motor
- **P3G30** Generator
- **P3L30** Line differential and Distance
- **P3T32** Transformer differential
- **P3M32** Motor differential
- **P3G32** Generator differential

Easergy Sepam

Easergy Sepam series digital protection relays take full advantage of Schneider Electric's experience in electrical network protection.



Easergy Sepam range

They provide all the necessary functions:

- Effective fault diagnosis and protection planning
- Accurate measurements and detailed diagnosis
- Integral equipment control
- Local or remote indication and operation
- Easy upgrading: communication, digital I/O, analog outputs, or temperature acquisition systems can be added, due to its modular design

Easergy MiCOM

Offers scalable levels of functionality and hardware options to best suit your protection requirements, and allows you to choose the most cost-effective solution for your application.



Easergy MiCOM range

The versatile hardware and common relay management software (Easergy MiCOM S1 Studio) allows simple configuration and installation in different applications.

A standard and simple user interface across the entire range makes Easergy MiCOM ideal in any environment, from the more complex bay level control with mimic, to the most simple LCD display with menu interrogation.

EcoStructure™ ready solutions

Arc fault mitigation relays

Modern society heavily depends on an uninterrupted supply of electric power. Prolonged power outages may cause irreversible damages, causing potential human loss and interruption of service continuity.

An arc flash protection unit is a protective device used to enhance the safety of the installation, protecting life and equipments.

Schneider Electric's range covers a wide range of application, from stand alone protection to a complete system.

Integrated

Protection relay with arc interface



- Integrated arc detection in 1-box solution with protection relay
- Openess to SCADA via the protection relay
- Less foot-print

Standalone



- Single stand-alone VAMP125 unit, protects busbar connection, circuit-breaker, CTs

Simple system

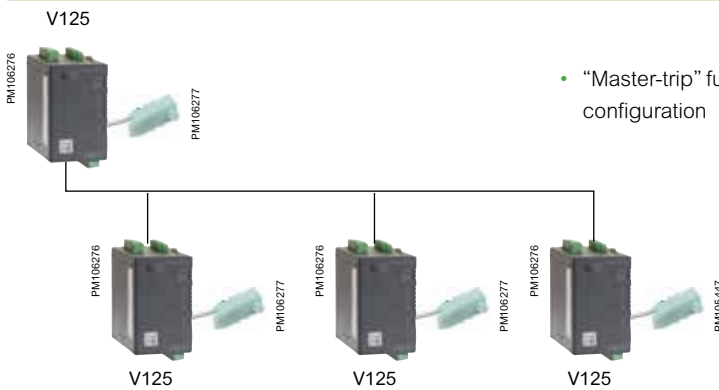

- "Master-trip" function, to allow simple selectivity in arc detection without strong configuration

High-end system

- Scalable and Customized Arc Detection system tailored to your needs
- Extended possibilities (number of inputs/outputs, logics, selectivity, etc.)
- Openess to several serial & Ethernet communication protocols, including IEC 61850
- Multiple technologies (point sensors, loop sensors, fiber optic, etc.)

EcoStructure™ ready solutions

Extend protection to the entire substation

- Possible to retrofit non-arc-resistant installations
- Integration in all products for new projects
- Connected to upper levels or totally stand alone system

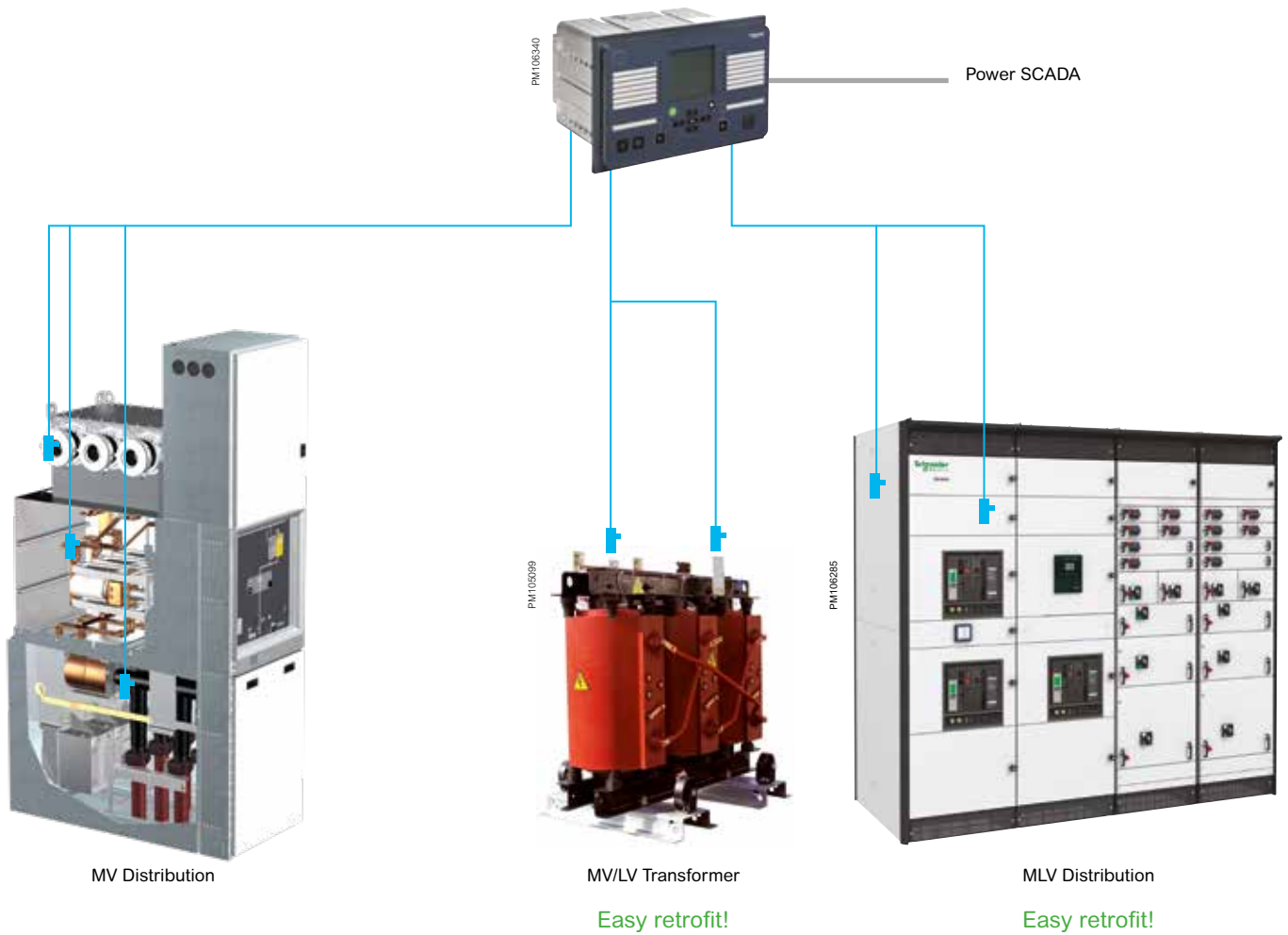

EcoStructure™ ready solutions

Real-time condition monitoring to optimize assets availability

Easergy CL110 ambient monitoring

Schneider Electric ambient monitoring system will continuously:

- Help maintenance manager to avoid deterioration of the MV switchgear due to moisture and pollution
- By automatically calculating the condensation cycle, and combining it with the declared mission profile conditions, the system will recommend maintenance and cleaning frequency adjustment in order to maintain the switchgear in its nominal status

Easergy TH110 thermal monitoring

Easergy TH110 is part of the new generation of wireless smart sensors ensuring the continuous thermal monitoring of all the critical connections made on field allowing to:

- Prevent unscheduled downtimes
- Increase assets availability
- Optimize and predictive maintenance

Thanks to its very compact footprint and its wireless communication, Easergy TH110 allows an easy and widespread installation in every possible critical points without impacting the performance of the MV Switchgears.

By using Zigbee Green Power communication protocol, Easergy Th110 ensure a reliable and robust communication that can be used to create interoperable solutions evolving in the Industrial Internet of Things (IIoT) age.

Easergy TH110 is self powered by the network current and it can ensure high performances providing accurate thermal monitoring.

Characteristics

Power supply	Self powered. Energy harvested from power circuit.
Accuracy	+/- 1°C
Range	-25 °C / +115°C
Wireless communication	ZigBee Green Power 2,4 GHz
Dimension - Weight	31 x 31 x 13 mm - 15 g



Protecting the environment

GHA - a comprehensive solution

The Environmental Management System for development, production, sales and servicing of GHA has been certified in conformity with the requirements in accordance with ISO 14001.



Protected environment

Schneider Electric's environmental policy has the following aims for all production sites:

- Reduction of the environmental footprint of our products and solutions over their entire service life by optimizing the consumption of resources and energy and by developing recycling solutions
- Provision of services which both meet environmental requirements and help our customers optimize their energy consumption
- Minimization of the environmental burden caused by our factories and plants by reducing the consumption of natural resources, avoidance of waste and emission and the utilization of the latest technologies
- Integration of all our members of staff, suppliers and partners in a process of continuous improvement together with our customers, to meet the company's requirements even better

These goals are secured over the long term, verified and continuously improved by a certified environmental management system for development, production, sales and service.

The GHA switchgear and control gear is a product which fully satisfies the requirements of environmental compatibility through:

- Minimized environmental impact during operation due to extremely low inspection and maintenance requirements. This is achieved by
 - Vacuum circuit-breakers with a high number of mechanical and electrical switching cycles
 - Low-maintenance drives
 - Zero-maintenance compartments designed as a sealed pressure system
- Use of recyclable materials to ensure maximum re-use at the end of their useful life
- No gas handling on the construction site during installation, extensions, dismantling or replacement of switchgear cubicles from the switchgear assembly
- Closed SF6 gas circulation from production to the end of the switchgear's service life
 - Re-use concept: Recycling of the used SF6 for re-use. SF6 gas is contained in a sealed pressure vessel. The quantity of SF6 is given on each individual nameplate on the equipment
 - The gas is recovered via self-sealing valves integrated in the GHA
 - The gas service unit is connected to the GHA for SF6 recovery via commercially available coupling adapters. No special cutting devices or tools are needed to connect the coupling adapters
 - The GHA contains SF6 gas, which has a global warming potential of 22800 compared to CO₂ (according to the 4th IPC assessment report and Annex I of EV regulation on fluorinated gases S17/2014).

The recyclability potential of GHA has been evaluated using the "ECO DEEE recyclability and recoverability calculation method" (version V1, 20 Sep. 2008 which serves as background calculation method for the IEC/TR 62635 ed1.0).

According to this method, the potential recyclability ratio without packaging is: 90% based on weight. As described in the recyclability calculation method this ratio includes only metals and plastics which have proven industrial recycling processes.

Quality assurance

Quality certified to ISO 9001

The Quality Management System for development, production, sales and servicing of GHA has been certified in conformity with the requirements in accordance with ISO 9001.

Certified quality: ISO 9001

At Schneider Electric, customer satisfaction is the Number One priority for everybody

- We undertake to find the ideal solution for each of our customers
- We are enthusiastic about our customers; our thinking and actions are clearly customer-oriented
- We encourage and empower our staff to always meet quality requirements

Each Schneider Electric production site has an established functional organization which ensures, monitors and continuously improves quality in line with norms and standards.

This process is

- Uniform at all sites
- Acknowledged by many customers and recognized organizations

Above all, there is a stringent Quality Management System which is audited on a regular basis by the international independent certification company Bureau Veritas Certification.

Schneider Electric Services

Peace of mind throughout your installation life cycle

How can you cut costs and improve performance at the same time?

When it comes to your electrical distribution infrastructure, the answer is straightforward: get professional expertise.

Life Cycle Services

DB4/0843

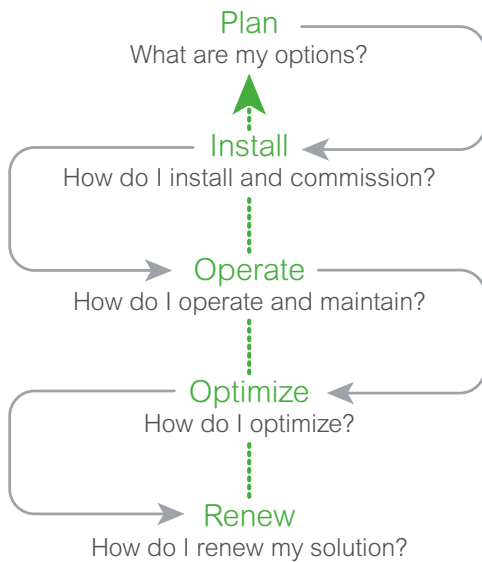

When it comes to your electrical distribution installation, we can help you:

- Increase productivity, reliability, and safety
- Mitigate risk and limit downtime
- Keep equipment up to date and extend lifespan
- Cut cost and increase savings
- Improve your return on investment

CONTACT US!

www.schneider-electric.com/b2b/en/services/

Plan

Schneider Electric helps you plan the full design and execution of your solution, looking at how to secure your process and optimize your time:

- **Technical feasibility studies:** Design solution in your environment
- **Preliminary design:** Accelerate turnaround time to reach a final solution design

Install

Schneider Electric will help you to install efficient, reliable and safe solutions based on your plans.

- **Project management:** Complete your projects on time and within budget
- **Commissioning:** Ensure your actual performance versus design, through on-site testing and commissioning, and tools and procedures

Operate

Schneider Electric helps you maximize your installation uptime and control your capital expenditures through its services offering.

- **Asset operation solutions:** Provide the information you need to increase safety, enhance installation performance, and optimize asset maintenance and investment
- **Advantage service plans:** Customize service plans that cover preventive, predictive and corrective maintenance
- **On-site maintenance services:** Deliver extensive knowledge and experience in electrical distribution maintenance
- **Spare parts management:** Ensure spare parts availability and optimized maintenance budget of your spare parts
- **Technical training:** Build necessary skills and competencies to properly and safely operate your installations

Optimize

Schneider Electric proposes recommendations for improved safety, availability, reliability and quality.

- **MP4 electrical assessment:** Define an improvement and risk management program

Renew

Schneider Electric extends the life of your system while providing upgrades.

We offer to take full responsibility for the end-of-life processing of old electrical equipments.

- **ECOFIT™:** Keep up to date and improve performances of your electrical installations (LV, MV, protection relays, etc.)
- **MV product end of life:** Recycle and recover outdated equipment with end-of-life services

GHA range

GHA range

General ratings	26
General overview	28
Low Voltage compartment	29
Busbar compartment	30
Gas compartment - Capacitive voltage dividers	32
Internal Arc classification	33
Loss of service continuity	34
Installation conditions	35
Degree of protection	36
Applicable standards	37

The GHA modules

Modular design provides high flexibility to better address all applications' requirements:

- single or double busbar
- outer or inner cone
- IAC AFL or AFLR

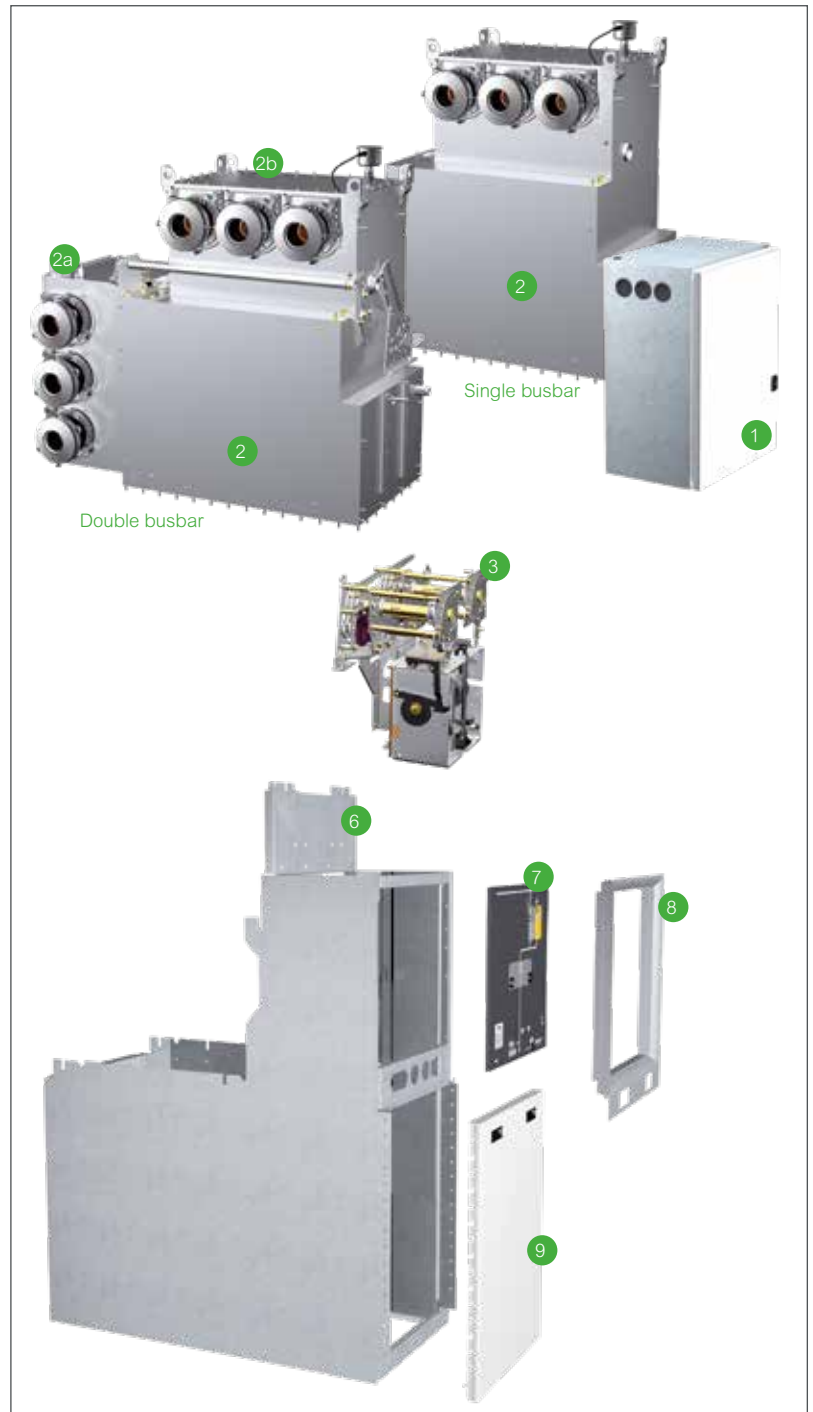

- 1 Low Voltage cabinet
- 2 Circuit-breaker module with busbars and three-position switch
- 2a Drive linkage for three-position switch SSI
- 2b Drive linkage for three-position switch SSII
- 3 Drive block
- 4a Outgoing feeder block with outer cone-type system, toroidal-core current transformer and actuation of the voltage transformer disconnecting device
- 4b Outgoing feeder block with inner cone-type system, up to 4 cable connection per phase with toroidal-core current transformer and voltage transformer
- 5 Voltage transformer (pluggable)
- 6 Panel rack
- 7 Control panel for SSI and SSII
- 8 Front mounting frame
- 9 Cable compartment cover

GHA switchgear and control gear ratings

The following data apply to normal operating and ambient conditions for indoor switchgear and control gear in accordance with IEC/EN 62271-1 at rated pressure.

GHA is certified and homologated according to several standards: ANSI, CSA, ENA, GOST, INAIL, etc.

Electrical characteristics

Rated voltage	(kV)	12	17.5	24	36	38	40.5
Rated lightning impulse withstand voltage	(kV)	75	95	125	170	170	185
Rated power frequency withstand voltage	(kV)	28	38 / (42)	50	70	70	80 / (95)
Rated peak withstand current	(kA)	100	100	100	100	100	100
Rated short-time current	(kA)	40	40	40	40	40	40
Rated busbar currents	(A)	2500 ⁽¹⁾	2500 ⁽¹⁾	2500 ⁽¹⁾	2500 ⁽¹⁾	2500 ⁽¹⁾	2500 ⁽¹⁾
Rated current of branch circuits, naturally ventilated	max. (A)	2500	2500	2500	2500	2500	2500
Internal Arc Classification (IAC) - IEC 62271-200	(kA/1s)	40	40	40	40	40	40

(1) Higher values up to 4000A on request



Design

Simple and Smart design

GHA is an optimum solution for different requirements and applications from transformer substations to switching stations for primary power supplies. GHA is perfectly suited for public and industrial distribution networks, infrastructural projects, mining, metallurgy, petrochemical oil and gas industries, railway traction power supply, container stations and ship building.

GHA is designed as a single or double busbar system.

This compact and modular switchgear offers both flexibility and a long, trouble-free service life. It is also ideally suited for applications in confined spaces or for replacing older switchgear - while permitting utilisation of the existing locations.

Single busbar panel GHA

- Gas-filled busbar compartment with three-position disconnect/earthing switch, connection valve for gas density switch, pressure relief device
- Gas-filled circuit-breaker compartment incl. connection elements for cable connections, connection valve for gas density switch, pressure relief device, voltage transformer and disconnecting device for voltage transformer (optional),
- Drive box with all drive units and auxiliary devices,
- Cable connection area, optional with toroidal-core current transformer incl. voltage transformer in outgoing feeder,
- Low-voltage cabinet.

Double busbar panel GHA

- Upper gas-filled busbar compartment with three-position disconnect earthing switch, connection valve for gas density switch, pressure relief device
- Rear gas-filled busbar compartment with two-position disconnect, connection valve for gas density switch, pressure relief device
- Gas-filled circuit-breaker compartment incl. connection elements for cable connections, connection valve for gas density switch, pressure relief device, voltage transformer and disconnecting device for voltage transformer (optional),
- Drive box with all drive units and auxiliary devices,
- Cable connection area, optional with toroidal-core current transformer incl. voltage transformer in outgoing feeder,
- Low-voltage cabinet.

PER0887



Single busbar

PER0888

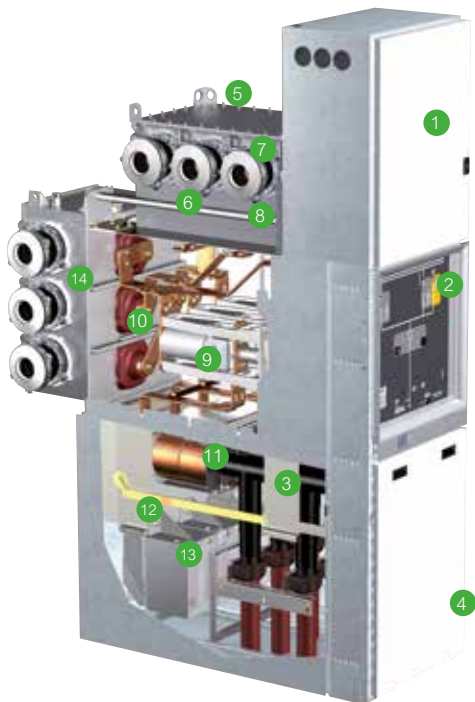

Double busbar

- 1 Low Voltage cabinet
- 2 Control panel
- 3 Cable end boxes
- 4 Cable connection compartment cover
- 5 Voltage transformer module on busbar
- 6 Gas-filled busbar compartment with three-position switch
- 7 Busbar module with disconnect
- 8 Three-position switch
- 9 Gas-filled compartment with circuit-breaker
- 10 Vacuum circuit-breaker
- 11 Toroidal-core current transformer
- 12 Disconnecting device for voltage transformer
- 13 Voltage transformer in outgoing feeder block
- 14 Busbar module (gas-filled) with two-position switch for double busbar



Ergonomic design of the control devices

Low Voltage cabinet

The spacious low-voltage cabinet is arranged on top of the GHA switchgear cubicle. As an autonomous functional unit, it is fully shrouded and encased in metal and is thus isolated from the high-voltage section and from the drive unit.

Low-voltage devices for control, monitoring and grid protection are normally installed in the rugged door of the low-voltage cabinet.

- Ergonomic design: The preferred installation height for control and monitoring devices is in the very easily accessible area
- The low-voltage cabinet can be mounted on the GHA switchgear cubicle either at the manufacturer's or on site
- Assembly / disassembly of the low-voltage cabinet is possible without problems.
 - The preassembled connection lines between the low-voltage cabinet and the GHA basic switchgear cubicle and the intra-panel switchgear-specific low-voltage ring mains between adjacent switchgear cubicles are plugged
- The external low-voltage lines are routed upwards from the bottom of the front right-hand cubicle into the low-voltage cabinet
 - These lines are routed in a separate metal duct with removable covers
 - The external lines are connected to a terminal block in the low-voltage cabinet of each GHA switchgear cubicle
- A specific cable laying system ensures optimum utilization of the inner arrangement of the low-voltage cabinet
- The height of the low-voltage cabinet is 800 mm
- A 1200 mm high low-voltage cabinet is also available as an option for larger capacity requirements



Low Voltage cabinet

Low Voltage instrument recess

Arranged below the low-voltage cabinet, the following items are installed there or are accessible via the removable front cover:

- Devices for voltage monitoring and testing via the capacitive voltage dividers
- Analog indicators for gas monitoring
- Valve for gas recovery at the end of the switchgear's service life



Replacing a section

Gas-insulated switchgear designed to avoid failures. Extensive use in demanding industries can lead the switchgear to be replaced earlier. GHA panel can be removed and replaced within few hours without gas-work even when installed in the middle of the line-up.

In case the control compartments are linked it is possible to remove the switchgear while keeping the daisy-chain connected.



Maintenance-free gas compartments

All high-voltage components are installed in gas-filled compartments and thus independent of external environmental influences.

The GHA gas tanks are made of chromium-nickel-steel.

They do not require any maintenance during the switchgear's anticipated service life.

The gas-filled compartments of the type-tested and metal-enclosed circuit-breaker switchgear systems are "sealed pressure systems" in accordance with IEC 62271-1.

This means that they are leakage-proof over their entire service life, so that neither maintenance work is required on these gas compartments nor replenishing of gas during the entire service life of the switchgear.



No gas work on site. Arrives ready to install

With GHA, no gas handling on site is required for erection, extension and dismantling at the end of the service life.

All gas-filled compartments are delivered to the site of installation with the rated filling pressure. All gas-filled compartments are completely tested for leakageproofness in the factory.

If necessary, replacement of panels from the switchgear assembly is possible without gas handling and without interfering with the gasfilled compartments of the adjacent panels.

This work is performed without moving the adjacent panels.

Innovative busbar connection system

The busbars of each GHA switchgear panel are largely installed in separate gas-filled compartments as required by the system.

Thus, they are independent of external environmental influences and integrated into the insulating gas monitoring.

To avoid all gas work on site, the connections of the busbars of adjacent GHA panels are established via the innovative B-link system.

Like the gas-filled compartments, the robust B-link system does not require any maintenance as it has IP65 protection degree.

The potential-controlled, externally grounded and flexible connecting sleeves of the B-link system distinguish themselves by extremely simple assembly and minimum electrical field intensities in the field of the high-quality electrical joints.

Busbar systems on the switchgear ends are closed with surge-proof terminal sleeve kits.

The reliability of the thermal and dynamic load-bearing capacity of the current-carrying connections of the B-link system with 40 kA (3s) and a peak current of 100 kA has been checked successfully.

Further advantages of the system are:

- The design with minimized electrical field intensity on the high-quality electrical joints reduces fault potential due to accidental contamination
- On-site assembly of the system is effected under visual supervision (you can see what you are doing).
- Straightforward and time- saving assembly on site reduces potential, site-specific negative influences.
- After removing B-link systems from between adjacent panels, an isolating distance can be established by means of end panel components in the busbar run without gas handling.

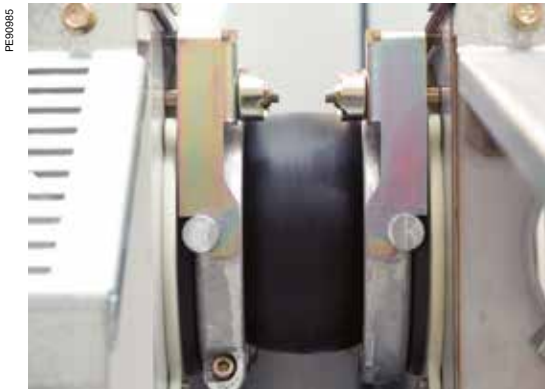

B-link, connected

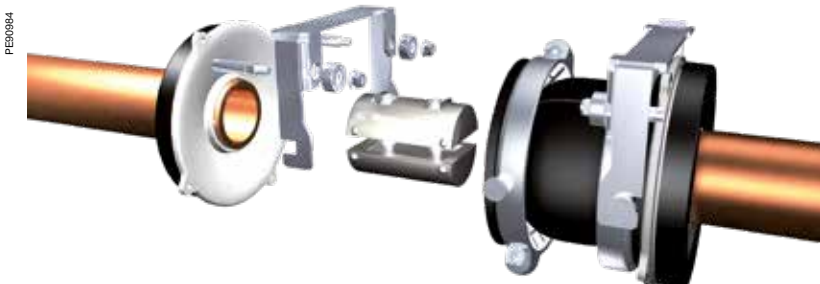

B-link, open

Gas compartment - Capacitive voltage dividers

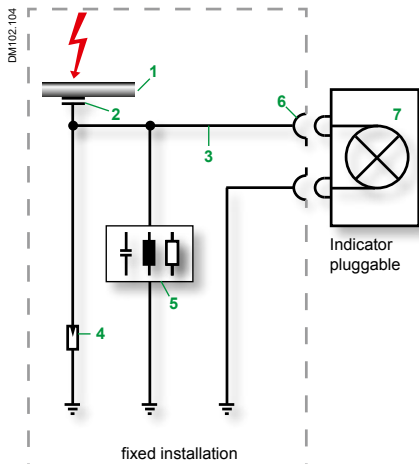

Non-integrated pluggable system

- 1 Live high-voltage conductor
- 2 Coupling capacitance: electrode in bushing
- 3 Internal connecting cable
- 4 Voltage-limiting predetermined break point
- 5 Measurement protection circuit
- 6 Standard sockets
- 7 Pluggable voltage

Voltage detection system (schematic diagram)

Capacitive voltage dividers

- Capacitive voltage dividers are installed in the outer cone-type standard bushings
 - On the outgoing feeder cable
 - On the busbar sections
 - Each for all three conductors L1-L2-L3
- They are an integral part of the testing, display and monitoring systems described separately, as for example:
 - Verification of safe isolation from supply
 - Digital display of the voltage values
 - Voltage monitoring / grid quality
 - Fault detection in the electrical distribution grid; earth fault in isolated / compensated systems

Clearly arranged gas compartment technology

The gas-filled compartments are sealed pressure systems in accordance with IEC/EN 62271-1.

- Maintenance-free
- Gas-filled compartments made of chromium-nickel-steel
- Leakproof over the entire service life
- During the expected service life, no maintenance work and no replenishing of insulating gas required (under normal ambient conditions)
- No gas handling and no intervention in the gas-filled compartment on site during
 - Installation
 - Extension
 - Replacement of switchgear cubicles
 - Dismantling of the switchgear

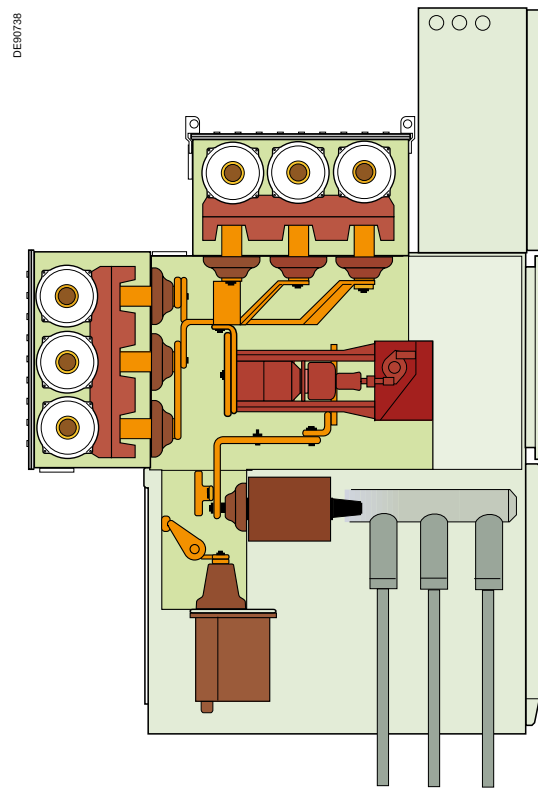

Clearly arranged gas compartment technology



Each gas-filled compartment is equipped with one or two pressure relief devices

- Open pressure relief device is protected against ejection
- Pressure relief in case of excess pressure in the lower cubicle area behind the cable connection area
- The pressure relief area is metallically segregated from the cable connection area

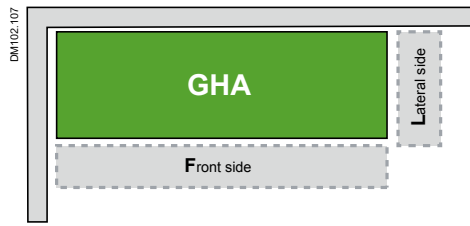

Internal arc classification IAC: accessible sides FL

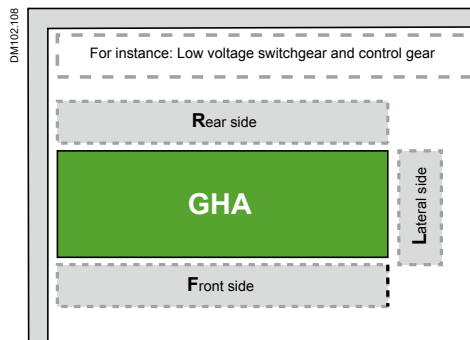

Internal arc classification IAC: accessible sides FLR

IAC	Internal Arc Classification
A	Accessibility A Restricted to authorized personnel only
F	For front side
L	For lateral side
R	For rear side
40 kA	Arc fault current 40 kA
1s	Arc fault duration 1s

Example of GHA with internal arc classification IAC

Internal faults causing internal arcs

- Due to its design, the GHA switchgear and control gear features a very low error probability.
 - No sources of interference due to external influence during operation
 - In accordance with IEC/EN 62271-200, avoiding internal arcs has top priority
 - The IEC/EN 62271-200, Table 102, recommendations include the use of gas-insulated switchgear as a preventive measure to avoid faults due to soiling, moisture, dust, vermin etc.
- The operating company is free to select a switchgear unit with internal arc classification IAC according to the applicable standards. According to IEC/EN 62271-200, switchgear cubicles with internal arc classification should only be used if the operating company considers the risk of danger to life due to internal arcs as essential.

Internal arc classification

- The internal arc classification IAC provides a verified level of operator safety in the immediate vicinity of the switchgear under normal operating conditions
- The internal arc classification is an option in accordance with IEC 62271-200 and EN 62271-200. It refers to the effect of internal excess pressure on covers, doors, inspection ports, vents etc. Moreover, the thermal effects of the internal arc and its root points on the enclosure and escaping hot gases or incandescent particles are taken into account.
- Metal-enclosed switchgear and control gear are granted Internal Arc Classification if all the following criteria are met:
 - Criterion No 1: Correctly secured doors and covers do not open
 - Criterion No 2: No fragmentation of the enclosure occurs during the arc fault duration
 - Criterion No 3: Arcing does not cause holes by burning through the classified sides up to height of 2000 mm
 - Criterion No 4: Indicators do not ignite due the effect of hot gases
 - Criterion No 5: The enclosure remains connected to the earthing point
- The internal arc classification IAC has been performed successfully for GHA
- As all operating and test procedures are performed on the front of the GHA, access via the front and the side walls is standard (IAC A FL)
 - The switching compartment depth can be minimized by wall-mounting of the switchgear
 - In this design, the GHA switchgear and control gear does not require a rear assembly aisle. Access, for example, to the cable compartment or the low-voltage cabinet, is only possible via the front
- If installation of the GHA is necessary in the switchgear room with access to the switchgear via the rear side, the switchgear can be provided with supplementary elements for internal arc classification IAC AFLR (optional)

Partition Class

- Partition class PM
 - segregation of the high-voltage compartments by continuous metallic partitions

Loss of service continuity category

The loss of service continuity category LSC according to IEC /EN 62271-200 defines the possibility to keep either high-voltage compartments and/ or functional units energised when opening an accessible high-voltage compartment.

- Loss of service continuity category for GHA with circuit breaker is LSC2, as the air-insulated compartments are accessible
- The gas-filled compartments of GHA are none-accessible compartments, according to 8.103.2 of IEC/EN 62271-200
 - No user access to this compartments is provided
 - And the opening may destroy the integrity of this compartments
- The busbar-system of a single-busbar switchgear and control gear is out of range of the definition for the LSC-category, according to 3.131.1.1 in IEC/EN 62271-200



Installation and operating conditions

The GHA's parts conducting high-voltage are entirely enclosed and unaffected by external ambient conditions.

- All high-voltage switchgear and control gear is installed in sealed gas-filled compartments
- Switchgear components subject to high voltage outside the gas-filled compartments are
 - Provided with a single-pole enclosure
 - Potential-controlled and earthed

Important functional parts which are not subject to high voltage such as drives, devices fulfilling control, protection, metering and monitoring functions can only be arranged outside the gas-filled compartment or the single-pole enclosure.

For safe and long-term operation, the normal operating conditions for indoor installation in accordance with IEC 62271-1 must be complied with (deviation conditions available on request).

- Ambient temperatures:
 - The ambient temperature does not exceed 40 °C
 - Its mean value over 24 hours does not exceed 35 °C
 - Minimum ambient temperature -5 °C (25 °C on request)
- Installation altitudes:
 - Max. 1000 m above sea level
 - Higher installation altitudes are in principle possible for GHA gas-insulated switchgear. Please inquire, stating the actual requirements
- Relative humidity

The following conditions apply regarding relative humidity:

 - The mean value of the relative humidity measured over 24 h does not exceed 95%
 - The mean value of the water vapour pressure measured over 24 h does not exceed 2.2 kPa
 - The mean value of the relative humidity measured over one month does not exceed 90%
 - The mean value of the water vapour pressure measured over one month does not exceed 1.8 kPa

Norms and standards

GHA switchgear cubicles correspond to the current norms and specifications in force at the time of type testing according to the following Table.

The international IEC standards have been accepted by CENELEC as European EN standards. The European standards EN have been transposed by the CENELEC members into national standards without changes to their contents.

PM1103.151



Degree of protection against hazardous parts and ingress of foreign objects

The metal-enclosed switchgear and control gear type GHA meets the requirements for degrees of protection, according to IEC/EN 62271-1, IEC/EN 50529 und IEC/EN 62262:

- Degree of protection provided by the enclosure for high-voltage live parts: IP 65
- Degree of protection provided by the enclosure against access to hazardous parts
- Front side of low voltage compartment: IP4X, optional IP52
- Front side of cable compartment: IP3X *
- Front of the mechanical operating panel: IP2X, *

* Other degrees of protection available on request

IEC/EN 62271-1 and IEC/EN 62271-200

Protection of persons against contact with dangerous parts and protection of equipment against penetration of solid foreign matter (IP code)

Degree of protection	Protection against ingress of solid foreign bodies	Protection against access to hazardous parts
IP2X	Objects of 12.5 mm diameter and greater	Access with a finger (test-finger 12 mm diameter, 80 mm long)
IP3X	Objects of 2.5 mm diameter and greater	Access with a tool (test-rod 2.5 mm diameter, 100 mm long)
IP4X	Objects of 1 mm diameter and greater	Access with a wire (wire-test 1.0 mm diameter, 100 mm long)
IP5X	Dust: The ingress of dust is not totally prevented but does not penetrate in a quantity or at a location such that it can interfere with the satisfactory operation of apparatus or to impair safety	Access with a wire (wire-test 1.0 mm diameter, 100 mm long)

GHA switchgear units can be operated as indoor switchgear under normal operating conditions in accordance with the standard IEC 62271-1.

Operation under conditions other than these is only admissible upon consultation with and with the consent of the manufacturer.

IEC standards

	Standards	EN
Switchgear	IEC 62271-200 IEC 62271-1	EN 62271-200 EN 62271-1
Internal arc classification	IEC 62271-200	EN 62271-200
Earthing switch	IEC 62271-102	EN 62271-102
Three position disconnecter	IEC 62271-102	EN 62271-102
Circuit-breaker	IEC 62271-100	EN 62271-100
Current transformers	IEC 61869-2	EN 61869-2
Inductive voltage transformers	IEC 61869-3	EN 61869-3
Appliance couplers, cable connection systems		EN 50181
Protection against accidental contact, foreign bodies and water	IEC 60529	EN 60529
Installation	IEC 61936-1	
Operation of electrical equipment		EN 50110-1
Insulating gas sulphur hexafluoride (SF6)	IEC 60376	
Use and handling of sulphur hexafluoride (SF6)	IEC 62271-4	

American standards (UL listed)

Specification	Standard
Guide for High-Voltage Circuit Breakers Rated on Symmetrical Current Basis Designated "Definite Purpose for Fast Transient Recovery Voltage Rise Times.	IEEE C37.06-2000
Standard Test Procedure for AC High-Voltage Circuit Breakers Rated on a Symmetrical Current Basis (R 2005), IEEE Application Guide for AC High-Voltage Circuit Breakers Rated on a Symmetrical Current Basis	IEEE C37.09-1999 IEEE C37.010-1999
Indoor Alternating Current High-Voltage Circuit Breakers Applied as Removable Elements in Metal-enclosed Switchgear - Conformance Test Procedures	ANSI C37.54-2002
Metal-Enclosed Interrupter Switchgear	IEEE C37.20.3-2001
Indoor AC Switches (1 kV-38 kV) for Use in Metal -Enclosed Switchgear	IEEE C37.20.4-2001
Switchgear - Metal-Enclosed Interrupter Switchgear Assemblies - Conformance Testing.	C37.57-2003 NEMA
Switchgear - Indoor AC. Medium Voltage Switches for Use in Metal-Enclosed Switchgear - Conformance Test Procedures	C37.58-2003 NEMA
Interrupter Switches for Alternating Current, Rated above 1000 V	IEEE 1247-1998
National Electrical Code (NEC)	NFPA 70-2005

Canadian standards (CSA certified)

Specification	Standard
Switchgear assemblies	C22.2 No. 31-04
High Voltage Isolating Switches	C22.2 NO. 58-M1989
High Voltage Full-Load Interrupter Switches	C22.2 No. 193-M1983 - Reaffirmed 2004

Railways application

GHA Rail, derived from GHA, has been developed to meet specific requirements from railway applications. It keeps all the innovative functionalities and simplicity of the GHA design.

GHA Rail is designed as a single busbar system for one and two pole configurations. This compact and modular switchgear offers both flexibility and a long, trouble-free service life.

GHA Rail has been fully tested according to IEC and European EN standards, as well as the appropriate national standards derived from them.

Standards and regulations	EN
Switchgear	EN 62271-200 / EN 62271-1
Railway application	EN 50163 / EN 50152-1 / EN 50152-2
Vacuum Circuit-Breaker	EN 62271-100
Disconnecter and earthing switch	EN 62271-102
Internal Arc Classification (IAC)	EN 62271-200
Protection against accidental contact, foreign objects and water	EN 60529
Current Transformers	EN 61869-2
Voltage Transformers	EN 61869-3
Voltage detection system	EN 61243-5
Installation	

GHA range

GHA IEC single busbar

GHA IEC single busbar

Functional overview	42
Feeder circuit breaker	44
Cable riser	45
Busbar sectionalizer with circuit breaker	46
Busbar disconnecter	47
Current transformer	48

FUNCTIONS

Feeder circuit breaker

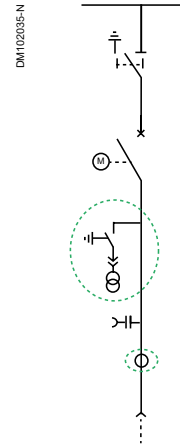

Un ⁽³⁾ (kV)	Ik (kA)	Cable connection	Ir (A)	Cubicle Dimensions		Cubicle width (mm)	
				Height ⁽¹⁾ (mm)	Depth ⁽²⁾ (mm)		
					IAC AFL		IAC AFLR
Up to 40.5	Up to 40	Outer Cones	630	2400 - 2800 (height of LVC 800/1200)	From 1400 to 1400	1600	600
			800				600
			1250				600
			1600				600/800 ⁽⁴⁾
			2000				600/800 ⁽⁴⁾
			2500				900
		Inner Cones	630	2400 - 2800 (height of LVC 800/1200)	From 1400 to 1400	1600	600
			800				600
			1250				600
			1600				600
			2000				600
			2500				900

(1) Height with a 800mm high low-voltage compartment & without any busbar attachment.
 (2) The deepest cubicle within the switchgear determines the overall depth.
 (3) Some cubicles may not be available for all voltage levels. Please consult us.
 (4) 600mm with 1x Outer cone type F, 800mm with 2 x outer cones type C.
 (5) Height of this cubicle in IAC AFL is 2600mm.



EXTENSIONS MODULES / OPTIONS

Busbar voltage transformer with disconnecting device

BB-VTS

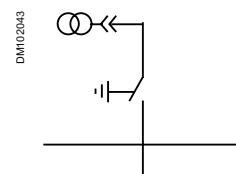

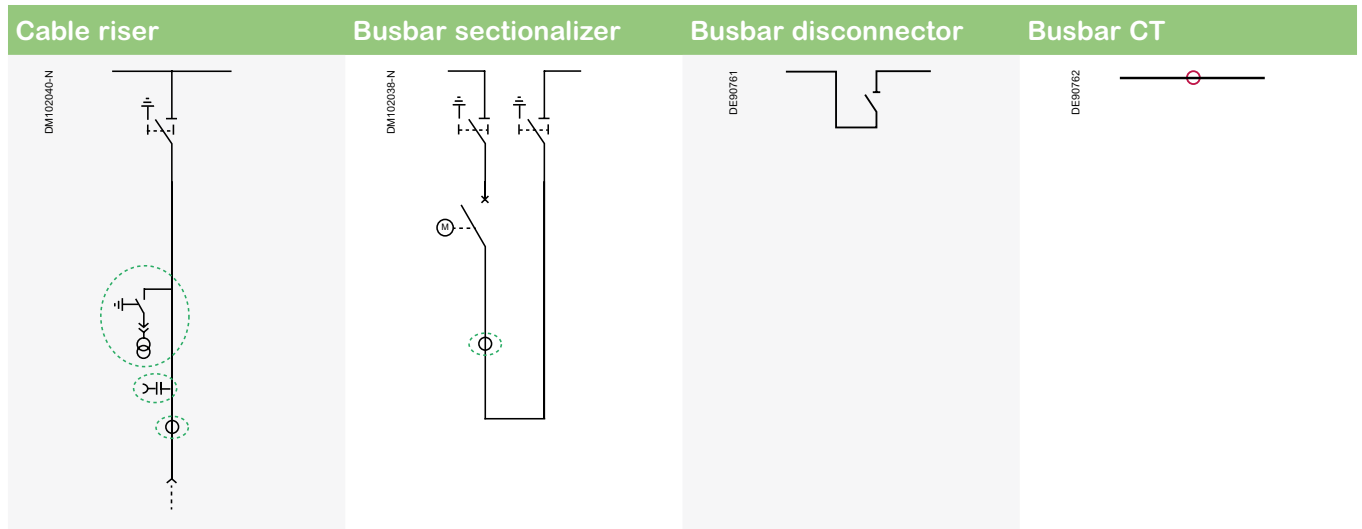

Cubicle width			
(mm)	(mm)	(mm)	(mm)
600	800	600	800
600	800	600	800
600	800	600	800
600/800 ⁽⁴⁾	800	600	800
600/800 ⁽⁴⁾	800	600	800
900	1000	--	1000
600	800	600	800
600	800	600	800
600	800	600	800
600	800	600	800
600	800	600	800
900	1000	--	1000

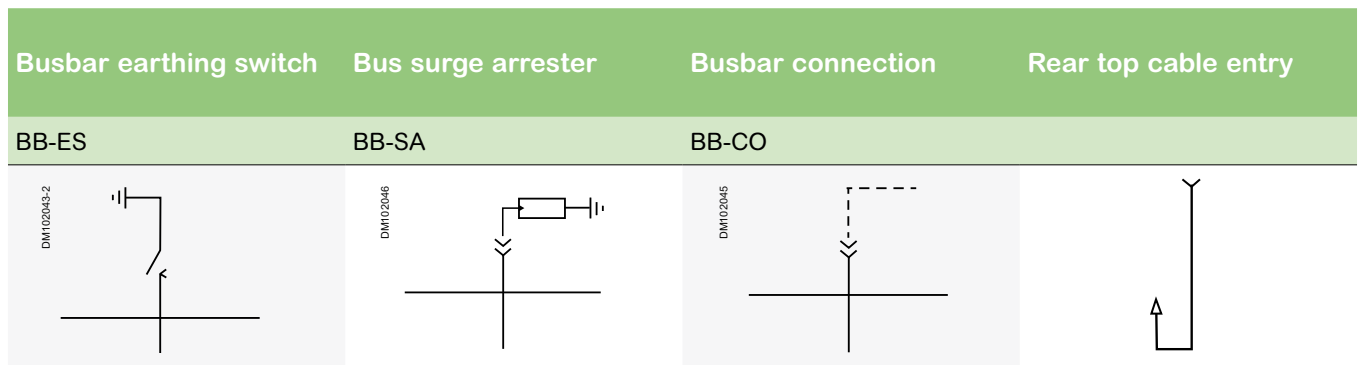



Outer cone cable connection



Option with inner cone cable connection

Circuit-breaker switchgear cubicle

Rated current feeder	A	800	1250	1600	2000	2500
Dimensions						
Height	LV cabinet 800 mm	mm 2400	2400	2400	2400	2400
	LV cabinet 1200 mm	mm 2800	2800	2800	2800	2800
	Busbar VT ⁽¹⁾	mm 2500	2500	2500	2500	2500
	Busbar earthing switch ⁽¹⁾	mm 2400	2400	2400	2400	2400
	Busbar surge arrester ⁽¹⁾	mm 2840/2400				

Outer cone cable connections						
Width	mm	600	600	600/800 ⁽²⁾	600/800 ⁽²⁾	900
Depth	mm	1400	1400	1400	1400	1400
Weight with all components fitted	kg	700	700	800	900	1100
Option inner cone cable connections						
Width	mm	600	600	600	600	900
Depth	mm	1400	1400	1400	1400	1400
Weight with all components fitted	kg	900	900	900	1000	1300

(1) Modules only for 600 mm wide cubicles

(2) 600 mm with 1x outer cone type F, 800 mm with 2x outer cones type C

Side view - dimensions

With outer cones

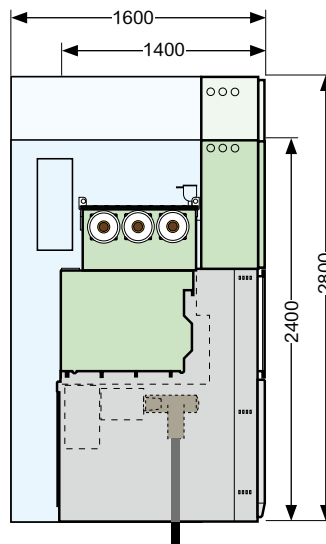

- LV cabinet 800 mm:
- LV cabinet 1200 mm:
- With pressure relief duct AFLR:

Functional diagram

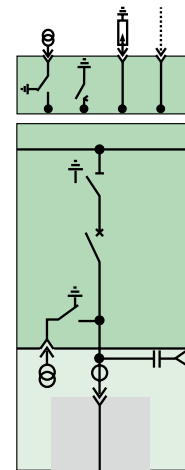

With inner cones (option)

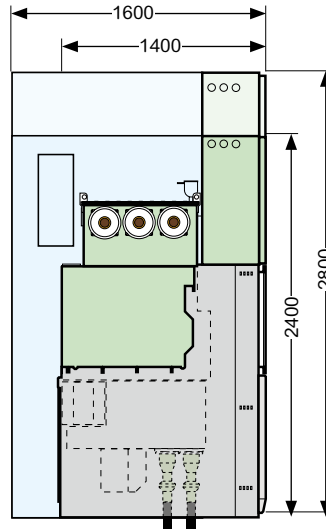

- LV cabinet 800 mm:
- LV cabinet 1200 mm:
- With pressure relief duct AFLR:

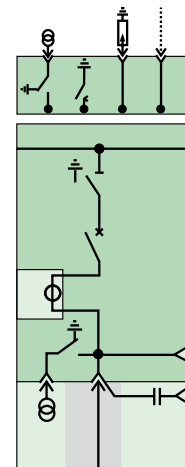

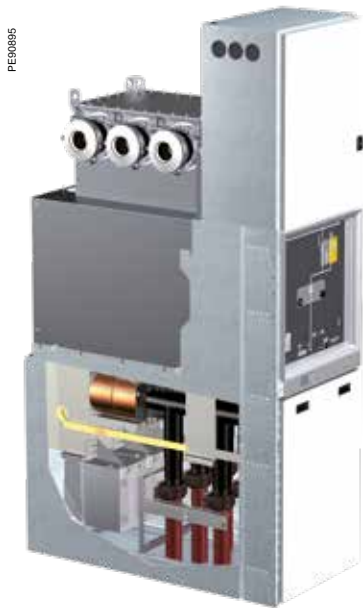

Outer cone cable connection



Option with inner cone cable connection

Cable riser cubicles

Rated current feeder	A	800	1250	1600	2000	2500
Dimensions						
Height	LV cabinet 800 mm	mm 2400	2400	2400	2400	2400
	LV cabinet 1200 mm	mm 2800	2800	2800	2800	2800
	Busbar VT	mm 2500	2500	2500	2500	2500
	Busbar earthing switch	mm 2400	2400	2400	2400	2400
	Busbar surge arrester	mm 2840/2400				

Outer cone cable connections

Width	mm	600	600	600/800 ⁽²⁾	600/800 ⁽²⁾	900
Depth	mm	1400	1400	1400	1400	1400
Weight with all components fitted	kg	700	700	800	900	1000

Option inner cone cable connections

Width	mm	600	600	600	600	900
Depth	mm	1400	1400	1400	1400	1400
Weight with all components fitted	kg	900	900	900	1000	1300

(1) Modules only for 600 mm wide cubicles

(2) 600 mm with 1x outer cone type F, 800 mm with 2x outer cones type C

Side view - dimensions

With outer cones

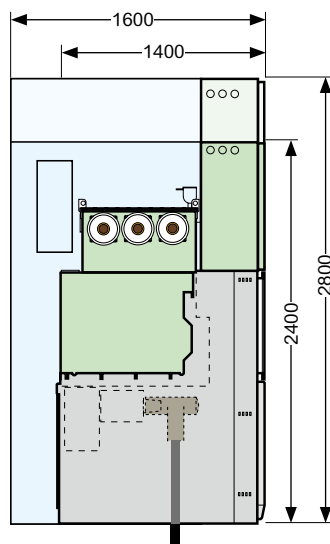

- LV cabinet 800 mm:
- LV cabinet 1200 mm:
- With pressure relief duct:
- AFLR:

Functional diagram

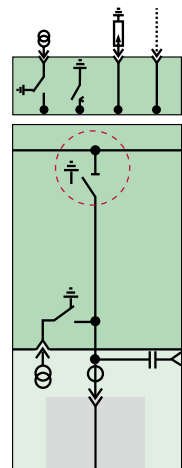

With inner cones (option)

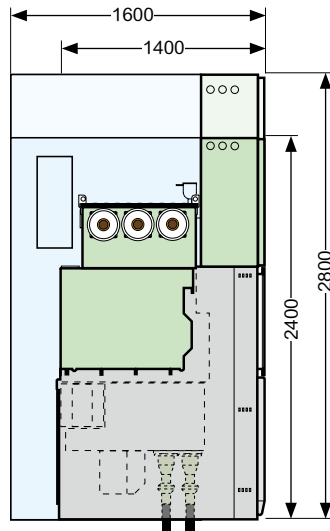

- LV cabinet 800 mm:
- LV cabinet 1200 mm:
- With pressure relief duct:
- AFLR:

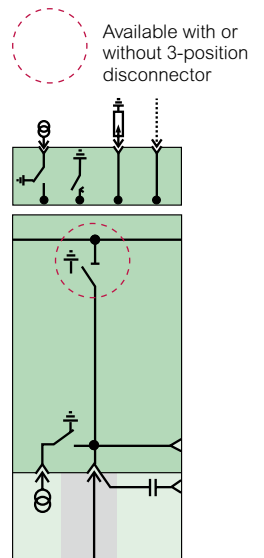

Busbar sectionalizer with circuit-breaker

PEE00893



Busbar sectionalizer with circuit-breaker

Rated current feeder	A	800	1250	1600	2000	2500
Dimensions						
Height	LV cabinet 800 mm	mm 2400	2400	2400	2400	2400
	LV cabinet 1200 mm	mm 2800	2800	2800	2800	2800
Width		mm 800	800	800	800	1000
Depth		mm 1400	1400	1400	1400	1400
Weight with all components fitted	kg	900	900	1000	1000	1300

Side view - dimensions

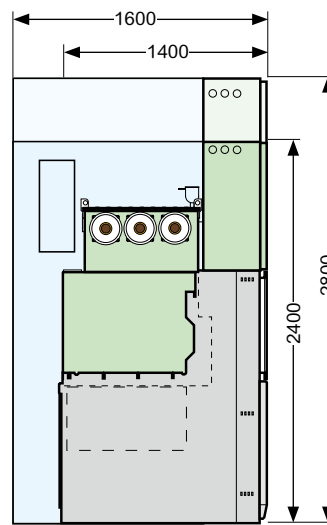

Functional diagram

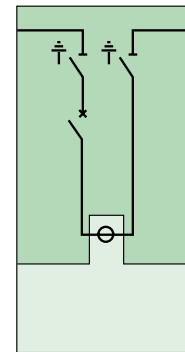

- LV cabinet 800 mm:
- LV cabinet 1200 mm:
- With pressure relief duct AFLR:

Busbar disconnecter



Busbar sectionalizer with circuit-breaker

Rated current feeder	A	800	1250	1600	2000
Dimensions					
Height	LV cabinet 800 mm	mm 2400	2400	2400	2400
	LV cabinet 1200 mm	mm 2800	2800	2800	2800
Width		mm 600	600	600	600
Depth		mm 1400	1400	1400	1400
Weight with all components fitted	kg	300	300	300	300

Side view - dimensions

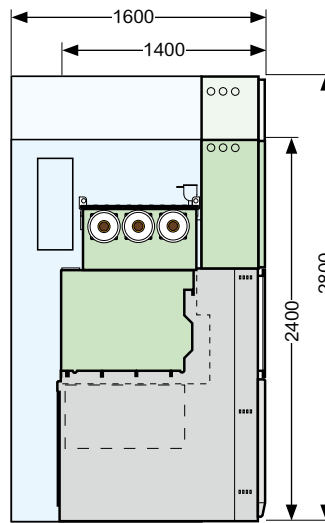

Functional diagram

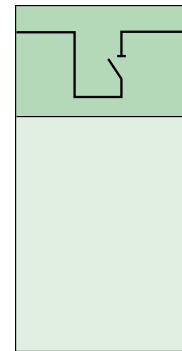

- LV cabinet 800 mm:
- LV cabinet 1200 mm:
- With pressure relief duct AFLR:

Current transformer



Current transformer

Rated current feeder	A	800	1250	1600	2000
Dimensions					
Height	LV cabinet 800 mm	mm 2400	2400	2400	2400
	LV cabinet 1200 mm	mm 2800	2800	2800	2800
Width		mm 600	600	600	600
Depth		mm 1400	1400	1400	1400
Weight with all components fitted	kg	300	300	300	300

Side view - dimensions

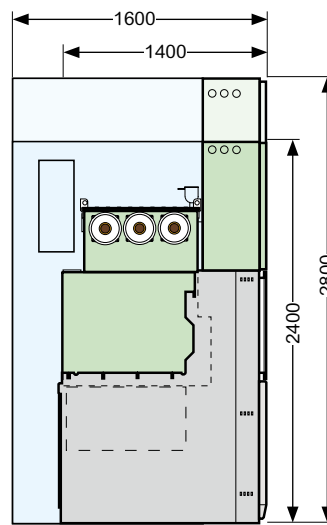

Functional diagram

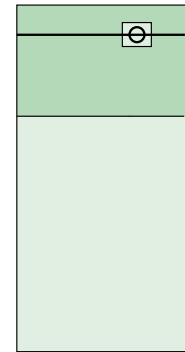

- LV cabinet 800 mm:
- LV cabinet 1200 mm:
- With pressure relief duct AFLR:

GHA IEC double busbar

GHA IEC double busbar

Functional overview	52
Feeder circuit breaker	54
Cable riser	55
Bus coupler	56
Busbar sectionalizer with circuit breaker	57
Busbar disconnecter	58
Busbar measurement	59
Voltage Transformer	59
Current Transformer	60
Busbar earthing switch	61

FUNCTIONS

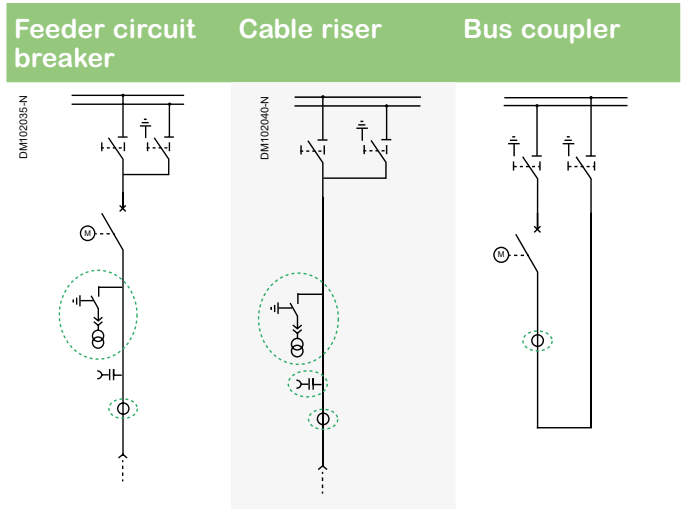

Un ⁽³⁾ (kV)	Ik (kA)	Cable connection	Cubicle Dimensions		Cubicle width (mm)		Cubicle width		
			Ir (A)	Height ⁽¹⁾ (mm)	Depth ⁽²⁾ (mm)		(mm)	(mm)	
					IAC AFL	IAC AFLR			
Up to 40.5	Up to 40	Outer Cones	630	2400	From 1700 to 2030	From 1985 to 2200	600	600	600
			800	600			600		
			1250	600			600		
			1600	600/800 ⁽⁴⁾			600/800 ⁽⁴⁾	600	
			2000	600/800 ⁽⁴⁾			600/800 ⁽⁴⁾	600	
			2500	900			900	900	
		Inner Cones	630	2400	From 1700 to 2030	From 1985 to 2200	600	600	
			800	600			600		
			1250	600			600		
			1600	600			600		
			2000	600			600		
			2500	900			900		

(1) Height with a 800mm high low-voltage compartment & without any busbar attachment.

(2) The deepest cubicle within the switchgear determines the overall depth.

(3) Some cubicles may not be available for all voltage levels. Please consult us.

(4) 600mm with 1x Outer cone type F, 800mm with 2 x outer cones type C.

(5) Height of this cubicle in IAC AFL is 2600mm.

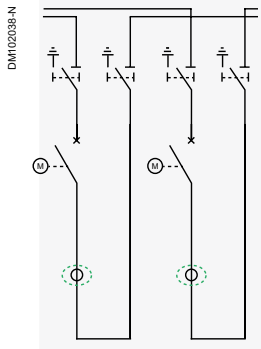
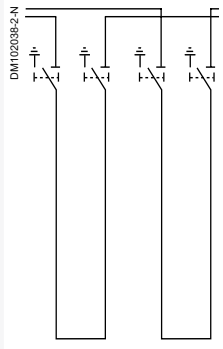
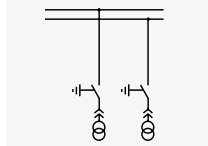
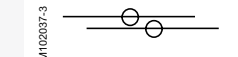
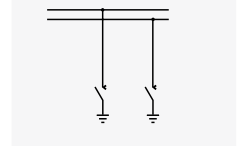
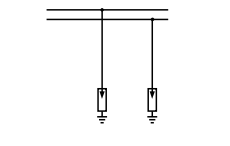

	Bus sectionalizer	Bus disconnector	Busbar VT's	Busbar CT's	Busbar earthing switch	Busbar surge arresters
						
	(mm)	(mm)	(mm)	(mm)	(mm)	(mm)
	2x 800	600	600	600 ⁽⁵⁾	600	600
	2x 800	600	600	600 ⁽⁵⁾	600	600
	2x 800	600	600	600 ⁽⁵⁾	600	600
	2x 800	600	600	600 ⁽⁵⁾	600	600
	2x 800	600	600	600 ⁽⁵⁾	600	600
	2x 1000	-	600	-	600	600

PE90906



Outer cone cable connection

PE90906-1



Option with inner cone cable connection

Circuit-breaker switchgear cubicle

Rated current feeder	A	800	1250	1600	2000	2500
Dimensions						
Height	LV cabinet 800 mm	mm 2400	2400	2400	2400	2400
	LV cabinet 1200 mm	mm 2800	2800	2800	2800	2800
Outer cone cable connections						
Width	mm	600	600	600/800 ⁽¹⁾	600/800 ⁽¹⁾	900
Depth	mm	1700	1700	1700	1900	1900
Weight with all components fitted	kg	900	900	900	1200	1400
Option inner cone cable connections						
Width	mm	600	600	800	800	900
Depth	mm	1700	1700	1700	1900	1900
Weight with all components fitted	kg	1100	1100	1100	1400	1600

(1) Modules only for 600 mm wide cubicles

Side view - dimensions

With outer cones

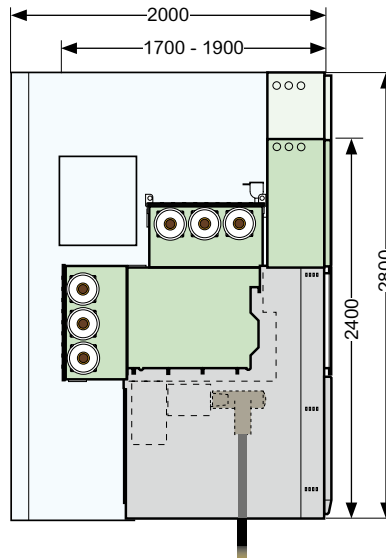

- LV cabinet 800 mm:
- LV cabinet 1200 mm:
- With pressure relief duct:
- AFLR:

Functional diagram

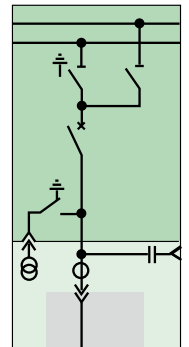

With inner cones (option)

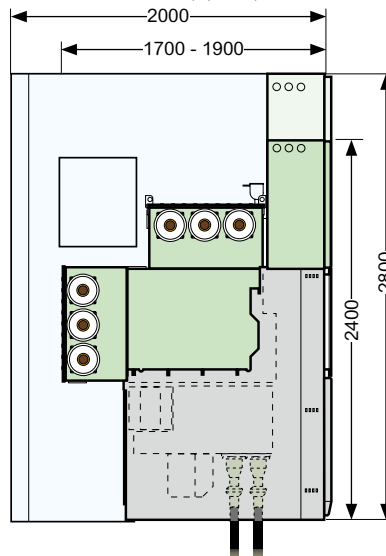

- LV cabinet 800 mm:
- LV cabinet 1200 mm:
- With pressure relief duct:
- AFLR:

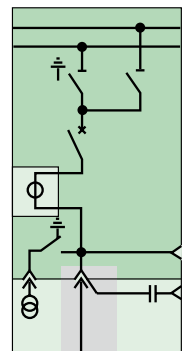

PE90906



Outer cone cable connection

PE90906-1



Option with inner cone cable connection

Cable riser cubicles

Rated current feeder	A	800	1250	1600	2000	2500
Dimensions						
Height	LV cabinet 800 mm	mm 2400	2400	2400	2400	2400
	LV cabinet 1200 mm	mm 2800	2800	2800	2800	2800
Outer cone cable connections						
Width	mm	600/800 ⁽¹⁾	600/800 ⁽¹⁾	800	800	900
Depth	mm	1700	1700	1700	1900	1900
Weight with all components fitted	kg	900	900	900	1200	1400
Option inner cone cable connections						
Width	mm	600	600	600	600	900
Depth	mm	1700	1700	1700	1900	1900
Weight with all components fitted	kg	1100	1100	1100	1400	1600

(1) 600 mm with 1x outer cone type F, 800 mm with 2x outer cones type C

Side view - dimensions

With outer cones

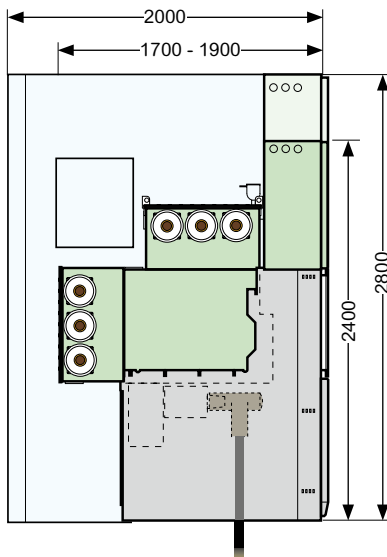

- LV cabinet 800 mm:
- LV cabinet 1200 mm:
- With pressure relief duct:
- AFLR:

Functional diagram

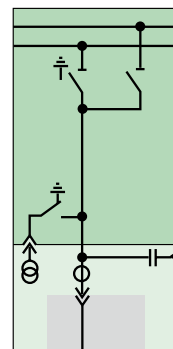

With inner cones (option)

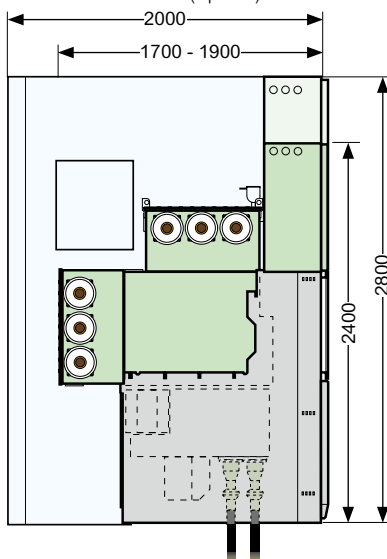

- LV cabinet 800 mm:
- LV cabinet 1200 mm:
- With pressure relief duct:
- AFLR:

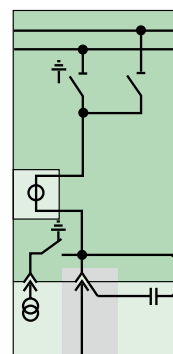

Bus coupler



Bus coupler						
Rated current feeder	A	800	1250	1600	2000	2500
Dimensions						
Height	LV cabinet 800 mm	mm	2400	2400	2400	2400
	LV cabinet 1200 mm	mm	2800	2800	2800	2800
Width		mm	600	600	600	900
Depth		mm	1700	1700	1700	1900
Weight with all components fitted		kg	900	900	900	1300

Side view - dimensions

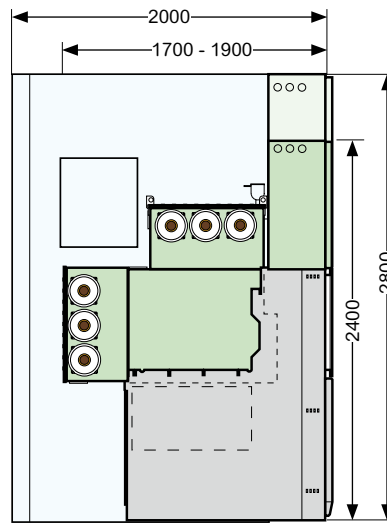

Functional diagram

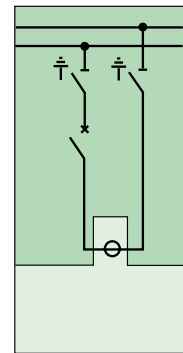

- LV cabinet 800 mm:
- LV cabinet 1200 mm:
- With pressure relief duct AFLR:

Busbar sectionalizer with circuit-breaker

PE90914



Busbar sectionalizer with circuit-breaker

Rated current feeder	A	800	1250	1600	2000	2500
Dimensions						
Height	LV cabinet 800 mm	mm 2400	2400	2400	2400	2400
	LV cabinet 1200 mm	mm 2800	2800	2800	2800	2800
Width		mm 2x800	2x800	2x800	2x800	2x1000
Depth		mm 1700	1700	1700	2000	2000
Weight with all components fitted	kg	1100	1100	1100	1400	1600

Side view - dimensions

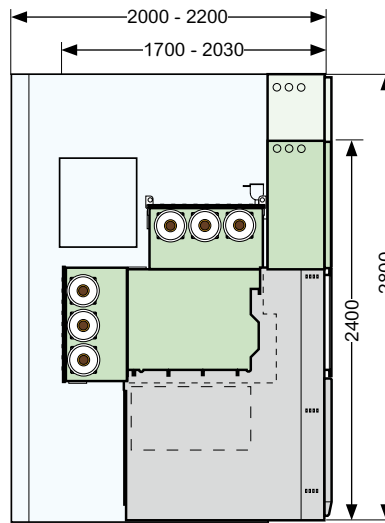

Functional diagram

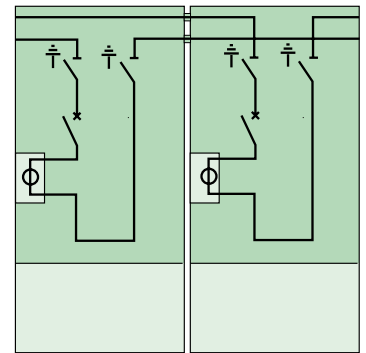

- LV cabinet 800 mm:
- LV cabinet 1200 mm:
- With pressure relief duct AFLR:

Busbar sectionalizer with circuit-breaker

Rated current feeder	A	800	1250	1600	2000
Dimensions					
Height	LV cabinet 800 mm	mm 2400	2400	2400	2400
	LV cabinet 1200 mm	mm 2800	2800	2800	2800
Width		mm 600	600	600	600
Depth		mm 1700	1700	1700	1900
Weight with all components fitted	kg	400	400	400	450

Side view - dimensions

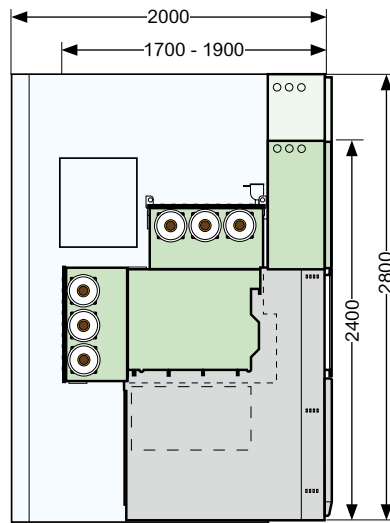

Functional diagram

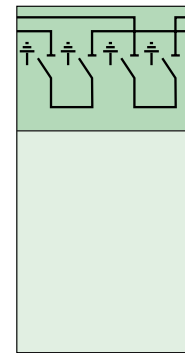

- LV cabinet 800 mm:
- LV cabinet 1200 mm:
- With pressure relief duct AFLR:

Busbar measurement

Voltage Transformer

PEB06007



Voltage Transformer

Rated current feeder	A	800	1250	1600	2000	2500
Dimensions						
Height	LV cabinet 800mm	mm 2400 ⁽¹⁾ /2500 ⁽²⁾				
	LV cabinet 1200mm	mm 2800	2800	2800	2800	2800
Width	mm	600	600	600	600	600
Depth	mm	1700	1700	1700	1700	1700
Weight with all components fitted	kg	520	520	520	520	520

(1) withdrawable laterally
(2) withdrawable upwards

Side view - dimensions

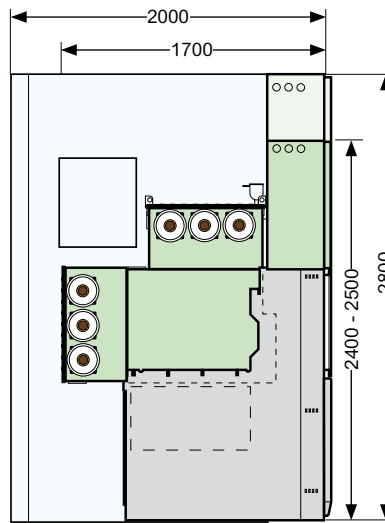

Functional diagram

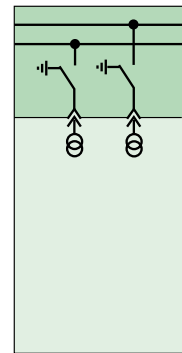

- LV cabinet 800 mm:
- LV cabinet 1200 mm:
- With pressure relief duct AFLR:

Busbar measurement

Current Transformer

Current Transformer					
Rated current feeder	A	800	1250	1600	2000
Dimensions					
Height	LV cabinet 800 mm	mm 2600	2600	2600	2600
	LV cabinet 1200 mm	mm 2800	2800	2800	2800
Width		mm 600	600	600	600
Depth		mm 1700	1700	1700	1700
Weight with all components fitted	kg	600	600	600	600

Side view - dimensions

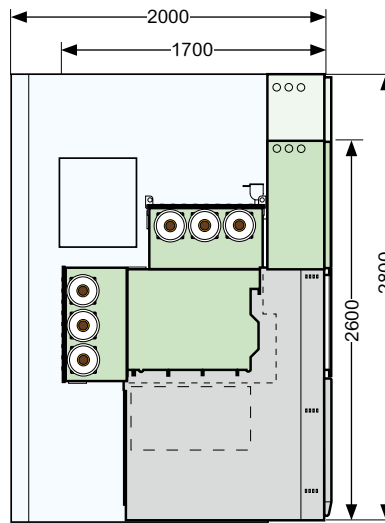

Functional diagram

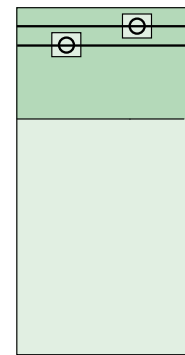

- LV cabinet 800 mm:
- LV cabinet 1200 mm:
- With pressure relief duct AFLR:

Bubar earthing switch

Bubar earthing switch

Rated current feeder	A	800	1250	1600	2000	2500
Dimensions						
Height	LV cabinet 800 mm	mm	2400	2400	2400	2400
	LV cabinet 1200 mm	mm	2800	2800	2800	2800
Width		mm	600	600	600	600
Depth		mm	1700	1700	1700	1700
Weight with all components fitted	kg		400	400	400	400

(1) withdrawable laterally
 (2) withdrawable upwards

Side view - dimensions

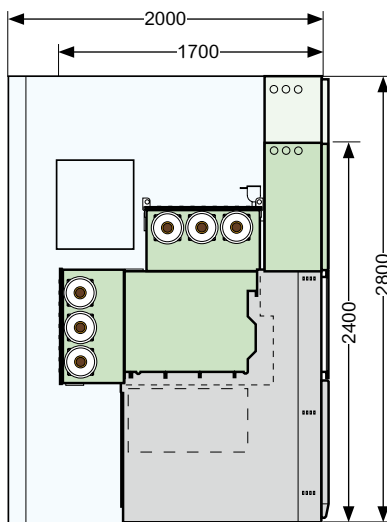

Functional diagram

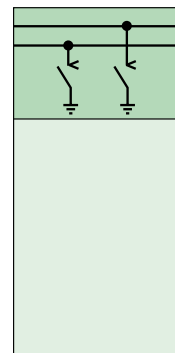

- LV cabinet 800 mm:
- LV cabinet 1200 mm:
- With pressure relief duct AFLR:

GHA Rail

GHA Rail

Product description	64
Functional overview	66
Feeder circuit breaker	68
Bus riser disconnecter	69
Busbar sectionalizer with circuit breaker	70
Busbar disconnecter	71



Technical characteristics (1 pole or 2 poles)

Nominal voltage	(kV)	25/25-0-25
Rated voltage	(kV)	27.5/27.5-0-27.5
Highest non permanent voltage for up to 5 minutes	(kV)	29/29-0-29
Highest non permanent voltage for up to 20 ms	(kV)	38.75/38.75-0-38.75
Rated overvoltage category	(OV4)	
Rated lightning impulse withstand voltage	(kV)	200/220
Rated power frequency withstand voltage	(kV)	95/110
Rated current busbar	(Up to A)	2000 ⁽¹⁾
Rated current feeder	(Up to A)	2000 ⁽¹⁾
Rated peak withstand current	(Up to kA)	63
Rated short-circuit breaking current	(Up to kA)	25 ⁽¹⁾
Rated short-time withstand current	(Up to kA/3s)	25 ⁽¹⁾
Rated frequency	max. (Up to Hz)	50
Internal Arc Classification (IAC)	AFL (R) -1s (Up to kA)	25

(1) Available up to 2500A, 31.5kA for 1 pole configuration.

GHA Rail, derived from GHA, has been developed to meet specific requirements from railway applications.

It keeps all the innovative functionalities and simplicity of the GHA design.

GHA Rail is designed as a single busbar system for one and two pole configurations. This compact and modular switchgear offers both flexibility and a long, trouble-free service life.

GHA Rail has been fully tested according to IEC and European EN standards, as well as the appropriate national standards derived from them.

Standards and regulations	IEC standard	EN standard
Switchgear	IEC 62271-200 / IEC 62271-1	EN 62271-200 / EN 62271-1
Railway application	IEC 62271-200 / IEC 62505-1 / IEC 62505-2	EN 50163 / EN 50152-1 / EN 50152-2
Vacuum circuit-breaker	IEC 62271-100	EN 62271-100
Disconnecter and earthing switch	IEC 62271-102	EN 62271-102
Internal Arc Classification (IAC)	IEC 62271-200	EN 62271-200
Protection against accidental contact, foreign objects and water	IEC 60529	EN 60529
Current transformers	IEC 61869-2	EN 61869-2
Voltage transformers	IEC 61869-3	EN 61869-3
Voltage detection system	IEC 61243-5	EN 61243-5
Installation	IEC 61936-1	

Normal service condition (IEC62271-1)		
Ambient temperature (min/max)	(°C)	from -5, optional -25, to +40 ⁽¹⁾
Average value over 24 hours (max)	(°C)	≤ 35 ⁽¹⁾
Average relative humidity (24 hours / one month)	(%)	≤ 95 / ≤ 90
Maximum altitude for installation above sea level	(m)	1000 ⁽¹⁾

(1) For more characteristics, please contact us.

FUNCTIONS (1 or 2 poles configuration)

Feeder circuit breaker

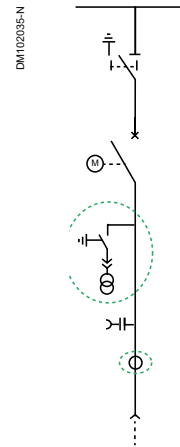

Un ⁽³⁾ (kV)	Ik (kA)	Cable connection	Ir (A)	Cubicle Dimensions		Cubicle width (mm)
				Height ⁽¹⁾ (mm)	Depth ⁽²⁾ (mm)	
Up to 27.5	Up to 25 ⁽³⁾	Inner Cones	1250 2000 ⁽³⁾	2400	IAC AFL	600
					IAC AFLR	
					From 1400 to 1400	600

(1) Height with a 800 mm high low-voltage compartment & without any busbar attachment.

(2) The deepest cubicle within the switchgear determines the overall depth.

(3) Available up to 2500A, 31.5kA for 1 pole configuration.



EXTENSIONS MODULES / OPTIONS

Busbar voltage transformer with disconnecting device

BB-VTS

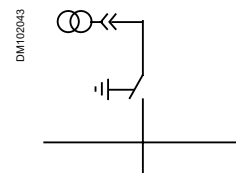

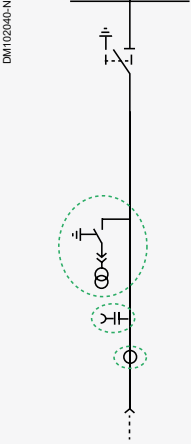
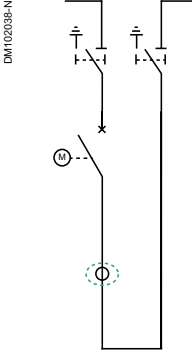
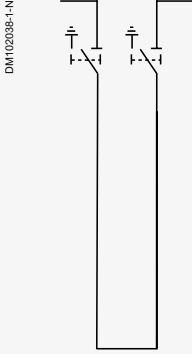
Cable riser	Bus sectionalizer	Bus disconnecter
 <p>DM102040-N</p>	 <p>DM102038-N</p>	 <p>DM102036-1-N</p>
Cubicle width		
(mm)	(mm)	(mm)
600	800	800
600	800	800

Feeder circuit-breaker with inner cone-type couplers

GHA-R image2



Circuit-breaker switchgear cubicle

Rated current feeder	A	1250	2000
Dimensions			
Height	LV cabinet 800 mm	mm 2400	2400
	LV cabinet 1200 mm	mm 2800	2800
	Busbar VT	mm 2500	2500
	Busbar earthing switch	mm 2400	2400
	Busbar surge arrester	mm 2840/2318	
Width		mm 600	600
Depth		mm 1400	1400
Weight with all components fitted	kg	650	750

Side view - dimensions

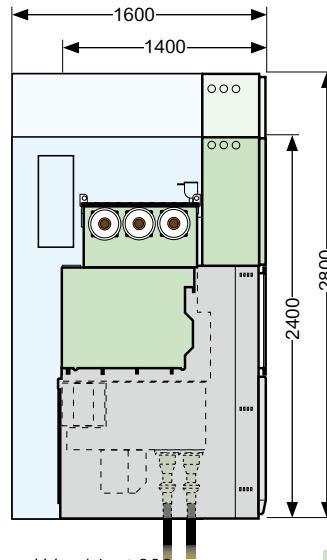

Functional diagram

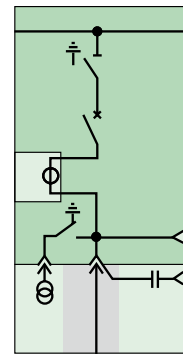

- LV cabinet 800 mm:
- LV cabinet 1200 mm:
- With pressure relief duct AFLR:

Bus riser disconnect with inner cone-type

GHA-R_image2



Cable riser cubicles

Rated current feeder		A	1250	2000
Dimensions				
Height	LV cabinet 800 mm	mm	2400	2400
	LV cabinet 1200 mm	mm	2800	2800
	Busbar VT	mm	2500	2500
	Busbar earthing switch	mm	2290	2290
	Busbar surge arrester	mm	2840/2318	
Width		mm	600	600
Depth		mm	1400	1400
Weight with all components fitted		kg	650	750

Side view - dimensions

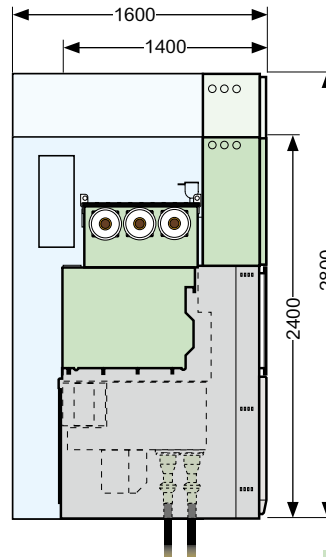

Functional diagram

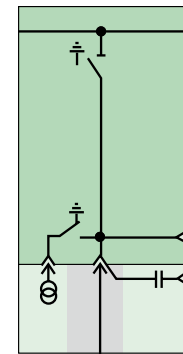

- LV cabinet 800 mm:
- LV cabinet 1200 mm:
- With pressure relief duct AFLR:

Busbar sectionalizer with circuit-breaker

GHA-R image



Busbar sectionalizer with circuit-breaker

Rated current feeder	A	1250	2000
Dimensions			
Height	LV cabinet 800 mm	mm 2400	2400
	LV cabinet 1200 mm	mm 2800	2800
Width		mm 800	800
Depth		mm 1400	1400
Weight with all components fitted	kg	850	1050

Side view - dimensions

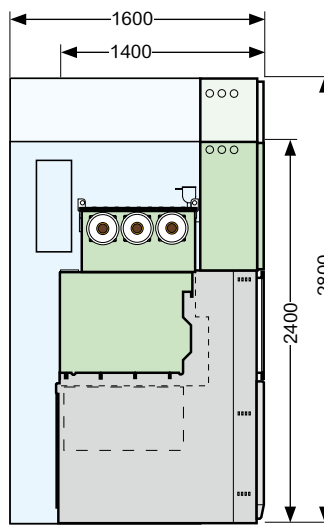

Functional diagram

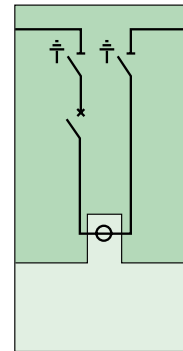

- LV cabinet 800 mm:
- LV cabinet 1200 mm:
- With pressure relief duct AFLR:

Busbar disconnecter

GHA-R image



Busbar sectionalizer with circuit-breaker

Rated current feeder	A	1250	2000
Dimensions			
Height	LV cabinet 800 mm	mm 2400	2400
	LV cabinet 1200 mm	mm 2800	2800
Width		mm 800	800
Depth		mm 1400	1400
Weight with all components fitted	kg	850	1050

Side view - dimensions

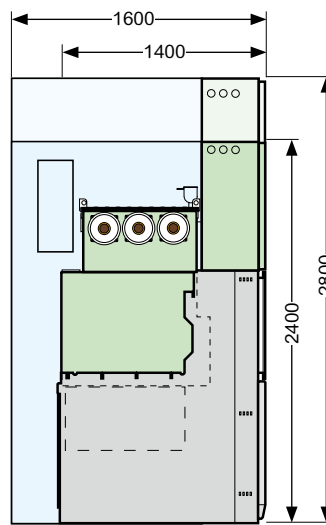

Functional diagram

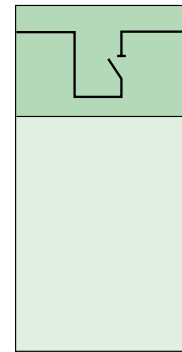

- LV cabinet 800 mm:
- LV cabinet 1200 mm:
- With pressure relief duct AFLR:

GHA ANSI

GHA ANSI

Applicable standards	74
Functional overview	76
Feeder circuit-breaker	78
Cable riser	79
Busbar sectionalizer	80

Applicable standards

Our GHA is UL and CSA certified for ANSI applications.
Ratings up to 38kV, 2500A and 40kA have been homologated.
Type testing has been partly performed according ANSI standards according to UL & CSA requirements.

Canadian standards	CSA certified
Switchgear assemblies	C22.2 No. 31-04
High-Voltage Isolating Switches	C22.2 No. 58-M1989
High-Voltage Full-Load Interrupter Switches	C22.2 No. 193-M1983 - Reaffirmed 2004

American standards	UL listed
American National Standard for AC High-Voltage Circuit Breakers - Rated on a Symmetrical Current Basis - Preferred Ratings and Related Required Capabilities	IEE C37.06-2000
IEEE Standard Test Procedure for AC High-Voltage Circuit Breakers Rated on a Symmetrical Current Basis	IEE C37.09-1999
IEEE Application Guide for AC High-Voltage Circuit Breakers Rated on a Symmetrical Current Basis	IEE C37.010-1999
Indoor AC High-Voltage Circuit Breakers Applied as Removable Elements in Metal-Enclosed Switchgear - Conformance Test Procedures	ANSI C37.54-2002
IEEE Standard for Metal-Enclosed Interrupter Switchgear	IEE C37.20.3-2001
IEEE Standard for Metal-Enclosed Interrupter Switchgear	IEE C37.20.4-2001
Switchgear - Metal-Enclosed Interrupter Switchgear Assemblies - Conformance Testing	C37.57-2003 NEMA
Switchgear - Indoor AC Medium-Voltage Switches for Use in Metal-Enclosed Switchgear - Conformance Test Procedures	C37.58-2003 NEMA
IEEE Standard for Interrupter Switches for Alternating Current, Rated Above 1000 Volts	IEE 1247-1998
National Electrical Code (NEC)	NFPA 70-2005

FUNCTIONS

Feeder circuit breaker

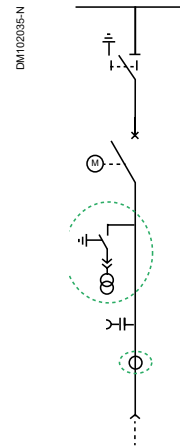

Un ⁽³⁾ (kV)	Ik (kA)	Cable connection	Ir (A)	Cubicle Dimensions		Cubicle width (mm)
				Height ⁽¹⁾⁽²⁾ (mm)	Depth ⁽³⁾ (mm)	
Up to 38	Up to 40	Outer Cones	1200	2400	Non-internal arc	600
					From 1400 to 1400	900
					Type 2B	900

(1) Height with a 800 mm high low-voltage compartment & without any busbar attachment.
 (2) Height can be increased by 200 mm, depending on VT and rating configuration.
 (3) The deepest cubicle within the switchgear determines the overall depth.



EXTENSIONS MODULES / OPTIONS

Busbar voltage transformer with disconnecting device

BB-VTS

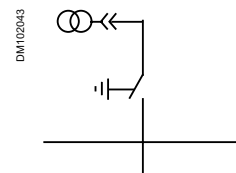

(4) No UL certification

Cable riser **Bus sectionalizer**

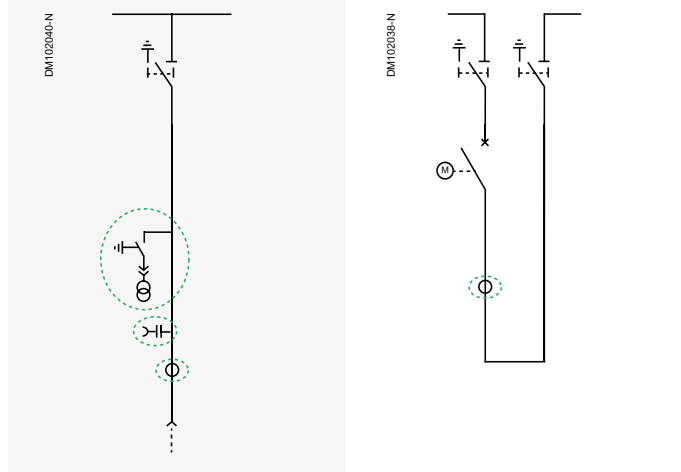

Cubicle width	
(mm)	(mm)
600	800
900	1000
900	1000

Busbar earthing switch **Bus surge arrester** **Busbar connection** **Rear top cable entry⁽⁴⁾**

BB-ES **BB-SA** **BB-CO**

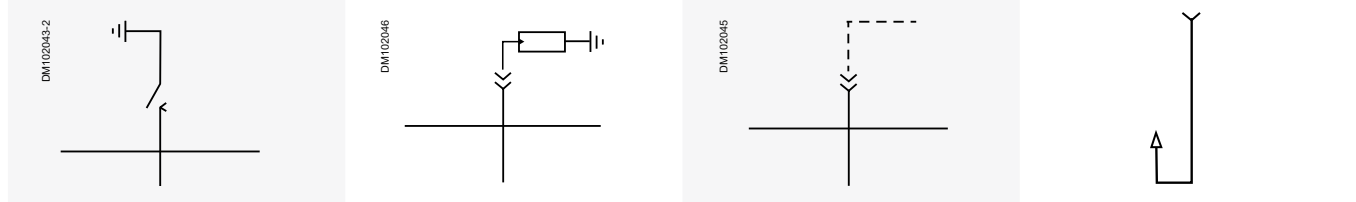

Feeder circuit breaker with outer cone-type couplers



Circuit-breaker switchgear cubicle

Rated current feeder		A	1200	2000	2500
Dimensions					
Height	LV cabinet 800 mm	mm	2400	2400	2400
	LV cabinet 1200 mm	mm	2800	2800	2800
	Busbar VT ⁽¹⁾	mm	2500	2500	2500
	Busbar earthing switch ⁽¹⁾	mm	2400	2400	2400
	Busbar surge arrester ⁽¹⁾	mm	2840/2400		
Width		mm	600	900	900
Depth		mm	1400	1400	1400
Weight with all components fitted		kg	700	900	1000

(1) Modules only for 600 mm wide cubicles

Side view - dimensions

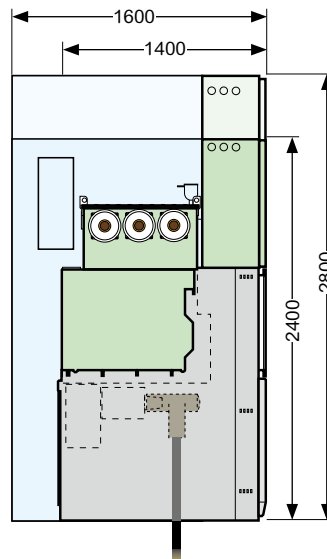

Functional diagram

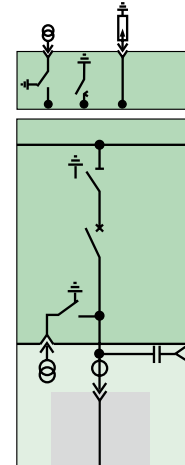

- LV cabinet 800 mm:
- LV cabinet 1200 mm:
- With pressure relief duct AFLR:

Cable riser

PEC09B95



Circuit-breaker switchgear cubicle

Rated current feeder	A	1200	2000	2500
Dimensions				
Height	LV cabinet 800 mm	mm 2400	2400	2400
	LV cabinet 1200 mm	mm 2800	2800	2800
	Busbar VT ⁽¹⁾	mm 2500	2500	2500
	Busbar earthing switch ⁽¹⁾	mm 2400	2400	2400
	Busbar surge arrester ⁽¹⁾	mm 2840/2400		
Width	mm	600	900	900
Depth	mm	1400	1400	1400
Weight with all components fitted	kg	700	900	1000

(1) Modules only for 600 mm wide cubicles

Side view - dimensions

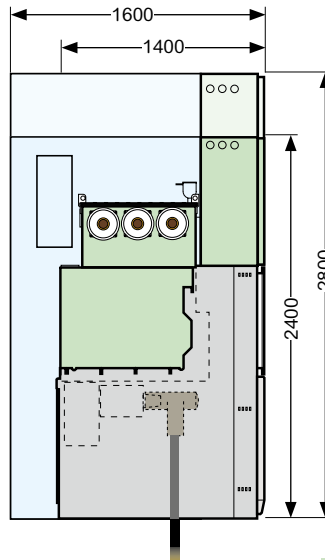

- LV cabinet 800 mm:
- LV cabinet 1200 mm:
- With pressure relief duct AFLR:

Functional diagram

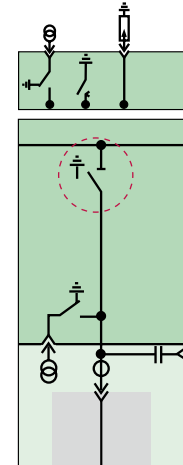

 Available with or without 3-position disconnecter

Busbar sectionalizer with circuit-breaker



PEE0893

Busbar sectionalizer with circuit-breaker

Rated current feeder	A	1200	2000	2500
Dimensions				
Height	LV cabinet 800 mm	mm 2400	2400	2400
	LV cabinet 1200 mm	mm 2800	2800	2800
Width		mm 800	1000	1000
Depth		mm 1700	2030	2030
Weight with all components fitted	kg	850	850	1040

Side view - dimensions

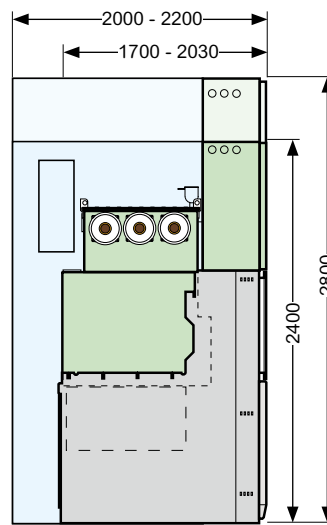

Functional diagram

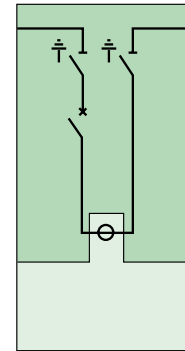

- LV cabinet 800 mm:
- LV cabinet 1200 mm:
- With pressure relief duct AFLR:

Components

Components

Switches	84
Vacuum circuit breaker	84
Operating Interface Circuit Breaker	86
Operating Interface 3 position disconnecter	87
Operating Interface & Interlocks	88
<hr/>	
Protection and control solutions	89
Auxiliary devices	89
Clearly arranged gas compartment technology	90
<hr/>	
Current transformer	91
<hr/>	
Voltage transformers	92
<hr/>	
Busbar fixtures	94
<hr/>	
Cable connections	95
<hr/>	
Cable testing	96
<hr/>	

Switching devices integrated in GHA

All live switchgear components of the switching devices and appropriate conductors between the operating equipment and components are fixed installations in the gas-filled compartments of the GHA switchgear cubicles. If the relevant operating instructions are adhered to, they are maintenance-free. Appropriate drive units are arranged outside the gas-filled compartment and are easily accessible from the front of the switchgear.

The following switching devices are located in the GHA's gas-filled compartments:

- Vacuum circuit-breaker
- Three-position disconnecter

Vacuum circuit-breaker technology

Within GHA, all operating and fault currents are switched via the innovative vacuum circuit-breaker technology. Here, currents are switched independently of the gas medium.

In GHA circuit-breaker switchgear cubicles, SF₆ gas is used as an insulating gas and not for interrupting electric arcs.

Using vacuum circuit-breaker technology, the requirements in the various medium-voltage distribution networks can be satisfied.

- Switching of cables, overhead lines, transformers, capacitors, generators and motors
- High number of mechanical and electrical switching operations without maintenance
 - 10000x mechanical switching operations
 - 10000x at rated current
 - 100x at rated short-circuit breaking current
- Straightforward design of the vacuum interrupter chambers
 - Few single parts
 - Straightforward mechanical workflows
 - Relatively small switching strokes of 8 to 10 mm between the contacts
 - Switching contacts in a high vacuum are unaffected by negative environmental influences and do not produce decomposition products
 - Long service life

Vacuum interrupter chambers

As long as 70 years ago, Schneider Electric conducted research into the possibilities of switching and breaking currents in a vacuum.

In the 1970s, Schneider Electric was the first to apply for a patent for the use of contact material based on chromium alloys. This alloy is still used successfully in vacuum interrupter chambers today.

Back in the 1980s, Schneider Electric started manufacturing ever increasing numbers of vacuum interrupter chambers for use in medium-voltage circuit-breakers.

The vacuum interrupter chamber consists of a ceramic insulator, the fixed and movable contact and the metal bellows sealing the movable contact against the ultra-high vacuum in the interrupter chamber. A concentric screen prevents condensation of metal vapours on the ceramic interior. This metal vapour can be created especially on switching OFF higher currents from the contact surfaces.

As soon as the closed contact elements are separated in the vacuum interrupter chambers by the drive mechanism, the electric arc (metal vapour arc) is generated in the ultra-high vacuum (< 10⁻⁷ hPa). This electric arc remains, as a rule, until the current reaches its zero crossing, and extinguishes within microseconds in an ultra-high vacuum.

After contact separation, fusible points are formed on the contact surface until extinction of the electric arc. This results in metal vapour.

In its vacuum interrupter chambers, Schneider Electric has been using Axial Magnetic Field technology (AMF) with great success for over 20 years. This technology provides a very good short-circuit breaking capacity with currents up to 63,000 A and optimum control of the electric arc via minimum contact erosion during interrupting the short-circuit currents.

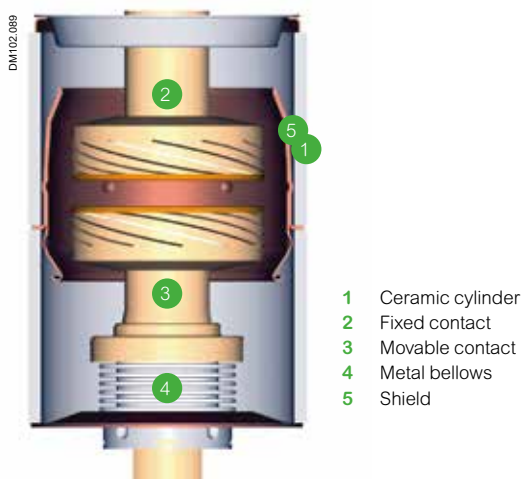

Vacuum interrupter design

Switches

Vacuum circuit-breaker

DEE0164

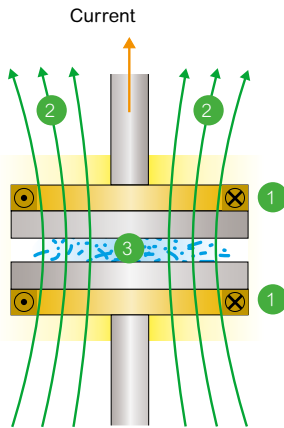

- 1 AMF contacts
- 2 Axial Magnetic Field (AMF)
- 3 Arc plasma

Principle of the Axial Magnetic Field (AMF)

Axial Magnetic Field technology (AMF):

At low breaking currents, the electric arc in the vacuum interrupter chamber burns with uniform distribution over the contact surface. Contact erosion is negligible and the number of possible current interruptions is very high.

- If the breaking current rises, exceeding at least the rated current, the so-called Hall effect occurs. The arc changes from diffuse state to a concentrated electric arc. As the current rises, the electric arc is increasingly constricted, forming a limited column.
 - High temperatures and consequently high thermal loads occur on the relevant areas of the switching contacts. This negative stress, however, is avoided thanks to the "rotating electric arc"
 - Due to the specific geometric shape of the switching contacts, a Radial Magnetic Field (RMF) forms due to the high arc current. This electromagnetic force with tangential effect sets the electric arc into very quick rotation on the contact surfaces.
- Schneider Electric uses the more recent and improved Axial Magnetic Field (AMF) technology in their vacuum interrupter chambers.
 - AMF involves the application of an axial magnetic field parallel to the axis of the two switching contacts
 - AMF ensures the diffuse shape of the electric arc is uniformly distributed over the contact surface - even at very high short-circuit breaking currents. A very large contact surface is utilized for the thermal stress imposed by the electric arc.
 - Thus, overheating and erosion at fixed points on the contact surface is optimized and consequently minimized.

Description

Circuit-breaker (CB)	Percentage value of DC component	29% - 35%
	Rated operating sequence ⁽¹⁾ ; electrical class CB	O-3 min-CO-3 min-CO; E2
	Opening time T_{op}	40 ms - 55 ms
	Closing time	55 ms - 65 ms
Number of mechanical operations without inspection	Mechanical operations, class	CB 10,000; M2 D 2000; M1 E 1000; M0
	Number of electrical operations without inspection, class	CB with rated (normal) current: 10,000 CB with rated short-circuit breaking current: 100
Command time	ON	20 ms
	OFF	20 ms

⁽¹⁾ others available on request
 D = Disconnecter
 E = Earthing switch

Switches

Operating Interface

Circuit Breaker

PER0978

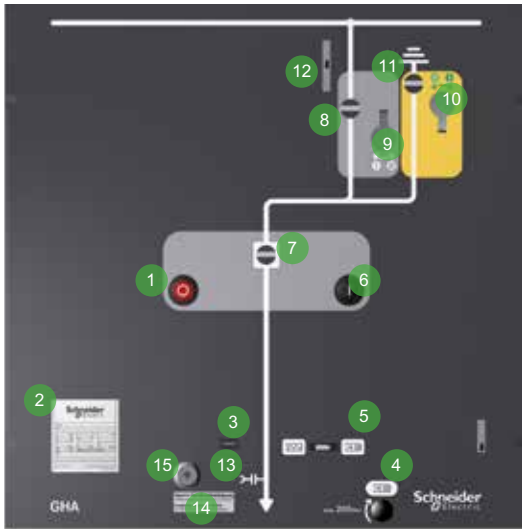

- 1 Pushbutton circuit-breaker OFF
- 2 Nameplate
- 3 Circuit-breaker operations counter
- 4 Insertion opening for charging the circuit-breaker's spring mechanism manually
- 5 Status indicator for spring mechanism released/charged
- 6 Pushbutton circuit-breaker ON
- 7 Switch position indicator, circuit- breaker
- 8 Switch position indicator, disconnecter
- 9 Insertion opening for operation of the disconnecter
- 10 Insertion opening for operation of the earthing switch
- 11 Earthing switch position indicator
- 12 Interrogation slide, disconnecter and earthing switches
- 13 Symbol for capacitive interface
- 14 Information sign
- 15 Mechanical lock-out with cylinder lock

Mechanical control panel - Operating area
Vacuum circuit-breaker - single busbar

Vacuum circuit-breaker drive

The three vacuum interrupter chambers are arranged horizontally in a row within the gas-filled compartment. They are actuated from the circuit-breaker drive via a common actuating shaft.

The position of the individual elements in the mechanical control panel has been optimized according to their function, i.e. according to their allocation to the corresponding device functions. The elements which form part of a switchgear device are visually linked by a specific pattern and integrated in a mimic diagram.

- Arranged outside the gas-filled compartment
- Easily accessible from the front of the switchgear
- Mechanical stored energy spring-mechanism for 10,000 mechanical switching operations
 - For auto-reclose operating sequences
 - Synchronization and quick change-over
- Trip free
- Charging the stored energy spring-mechanism using an integrated motor
 - Manual emergency charging of the stored energy spring-mechanism is possible e.g. on commissioning or in the event of failure of the auxiliary voltage on the front-mounted mechanical control panel
- Comprehensive equipment for control and monitoring (see separate list)

Closing procedure (ON):

The stored energy spring-mechanism is latched in the charged position. The mechanical indicator "Spring energy accumulator charged" appears. Closing is either performed via the mechanical ON button in the control panel or via magnetic shunt closing releases.

After switching ON, the stored energy spring-mechanism is recharged automatically (in the case of the motor drive mechanism).

Opening procedure (OFF):

The vacuum circuit-breaker is switched OFF either via the mechanical OFF button in the control panel or via magnetic shunt opening releases.

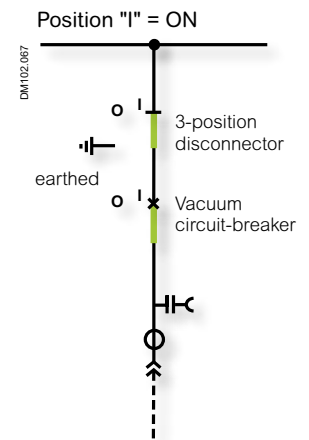
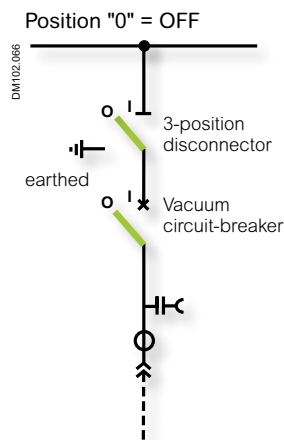

Switches

Operating Interface

3-Position disconnecter

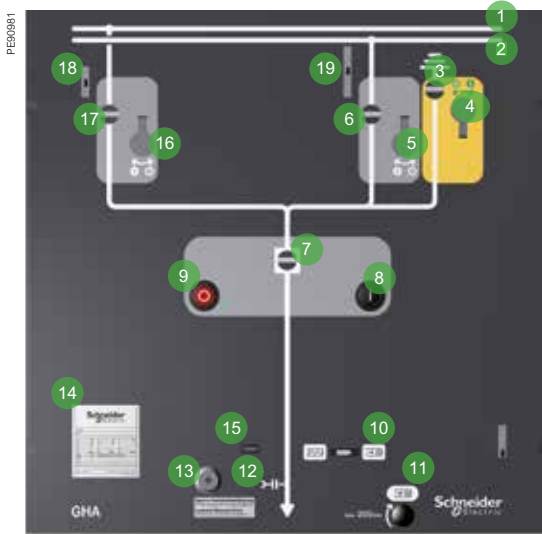

- 1 Busbar 1
- 2 Busbar 2
- 3 Position indicator of earthing switch
- 4 Insertion opening for charging the circuit-breaker's spring mechanism manually
- 5 Status indicator for spring mechanism released/charged
- 6 Pushbutton circuit-breaker ON
- 7 Switch position indicator, circuit- breaker
- 8 Pushbutton circuit-breaker ON
- 9 Pushbutton circuit-breaker OFF
- 10 Status indicator for spring mechanism released/charged
- 11 Insertion opening for charging the circuit-breaker's spring mechanism manually
- 12 Symbol for capacitive interface
- 13 Mechanical lock-out mechanism with cylinder lock
- 14 Nameplate
- 15 Circuit-breaker operations counter
- 16 Insertion opening for operation of the disconnecter, busbar 1
- 17 Position indicator for disconnecter, busbar 1
- 18 Interrogation slide for disconnecter, busbar 1
- 19 Interrogation slide for disconnecter, busbar 2 and (outgoing) earthing switch

Three-position disconnecter

The three-position disconnecter is used for:

- Connection to/disconnection from the busbar system
- Earthing and short-circuiting the outgoing feeder – together with the vacuum circuit-breaker
- The isolating distance conditions for safe working on the outgoing feeder are also established by means of the three-position disconnecter

Drives for three-position disconnecters

Although the three-position disconnecter is designed as a switchgear device on the high-voltage side, mechanical operation and remote actuation are performed via separate drive mechanisms with their own switch position indicators for the "Disconnecter ON-OFF" and "Earthing switch ON-OFF" functions.

- These functions can also be equipped with separate motor drives, auxiliary switches, blocking coils etc.
- Operation on the switchgear cubicle and via remote access uses a disconnected earthing switch in the outgoing feeder, as with conventional switchgear.
- The two separate drives increase user-friendliness and operating safety of the GHA switchgear
- GHA can be integrated into a SCADA-system just like a conventional switchgear with installed disconnecter + circuit-breaker + disconnected earthing switch
- In the double busbar configuration an additional 2-position disconnecter is integrated to connect the circuit-breaker to the second busbar.

Mechanical control panel - Operating area Three-position disconnecter - Double busbar

Switches

Operating interface & interlocks



State of the art operating interface

User Friendly is our Brand Mark

GHA provides a reliable and user friendly operating interface. The switch positions are displayed mechanically in the control panel. The mechanical switch position indicators as well as actuation of the drives are integrated in a very clear mimic diagram in the control panel and directly visible at any time. The switches are arranged in a logical and user friendly manner, facilitating local operation.

Optionally, all switches can be suited with padlocking provision to prevent mechanical actuation.

An additional cylinder lock-type interlock is installed as standard in case the disconnecter and earthing switch are motorized. This interlock releases "either manual or electrical actuation of the drives.

Internal mechanical interlocks of the panel

- With the circuit-breaker closed, the interrogation slide is locked for the disconnecter and the earthing switch.
- The interrogation slide always releases one insertion opening only (disconnecter or earthing switch), or both of them are locked.
- The crank for the disconnectors and earthing switches can only be removed in its appropriate end position.
- The earthing switch can only be actuated in direction ON with the circuit-breaker's spring mechanism charged (intertripping circuit of circuit-breaker during earthing).
- When the crank on the disconnecter or earthing switch is still in place, or when the interrogation slide is open, the following components are locked:
 - ON pushbutton of circuit-breaker
 - ON pulse is interrupted
- In panels featuring two interrogation slides (e. g. double busbar panel, bus section coupler and bus coupler), the following features are locked:
 - Both interrogation slides cannot be opened simultaneously.
 - The interrogation slides are blocked depending on the position of the disconnecter or earthing switch (see interlock tables).
- Electro-mechanical blocking coils can be used for inter-panel interlocks, as well as for additional intra-panel interlocks.



Optionally, padlocking provision to prevent mechanical actuation

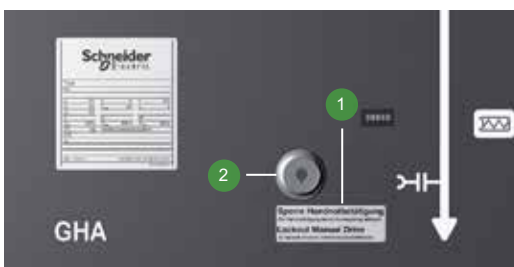

- 1 Mechanical lock-out mechanism with cylinder lock
- 2 Information plate

Earthing of the cables in 1 operation

Our GHA include the unique feature of doing the earthing of the cables in one operation. Indeed when closing the earthing switch, the vacuum interrupter will be actuated automatically, through a mechanical shaft.

The vacuum interrupter cannot be re-opened, as long as earthing switch is closed.

Integral outgoing feeder earthing

The outgoing feeder is earthed and short-circuited by means of the three-position disconnecter in combination with the vacuum circuit-breaker.

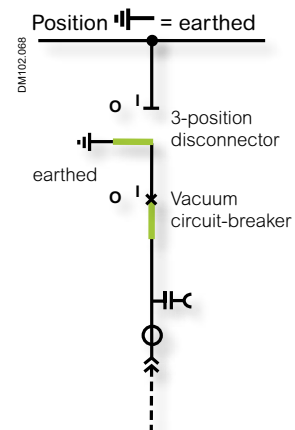

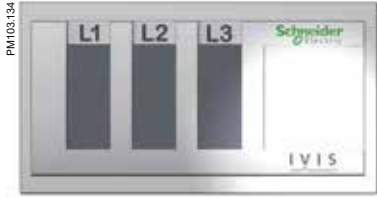

Integrated voltage detecting system IVIS – "zero voltage" indication



Three-phase indication "Voltage present" on the IVIS display

IVIS Integrated Voltage Detection System

IVIS – integrated voltage detection system – can be installed optionally in any GHA switchgear cubicle with capacitive voltage divider.

IVIS – integrated voltage detection system – is used to ascertain:

- The presence of operating voltage
- Isolation from the power supply
- Phase comparison

A display with LCDs indicates on the IVIS the capacitive decoupled voltage of the primary conductor for each phase. IVIS continuously checks that the following conditions in accordance with the relevant standard IEC/EN 61243-5 are satisfied:

- The response conditions for unambiguous indication of "Voltage present/absent" and
- The conditions for repeat testing of integrated voltage indication systems

Only if these two conditions exist the IVIS displays a continuous flash for each phase.

The system monitors continuously the test circuit according to the above-mentioned criteria and indicates non-compliance with the conditions for the repeat test by an discontinued flash. In this case, the system must be checked.

The IVIS system has been designed for maximum operating reliability:

- Maintenance-free
 - Weather-proof encapsulated electronics
 - No repeat tests required using mobile equipment
- No auxiliary voltage required
- Continuous integrated repeat testing of the interfaces in the entire circuit for zero voltage verification

Protection and control solutions

Clearly arranged gas compartment technology



IDIS display Display of gas status

Each gas-filled compartment is autonomous. It is monitored by the gas density information system IDIS.

The gas status in the gas-filled compartment is detected by means of a pressure sensor whose electrical signals are retransmitted to the separate IDIS display.

The gas status is monitored on the panel front below the control panel on a panel display, and separately for each gas compartment by LEDs in the following colours:

- green (OK)
- yellow (pre-warning level),
- red (main warning level).



Pressure sensor, mounted on self-locking disposal connector

If at least one warning level reacts, this message can be signalled remotely as a common gas warning group signal for the entire switchgear.

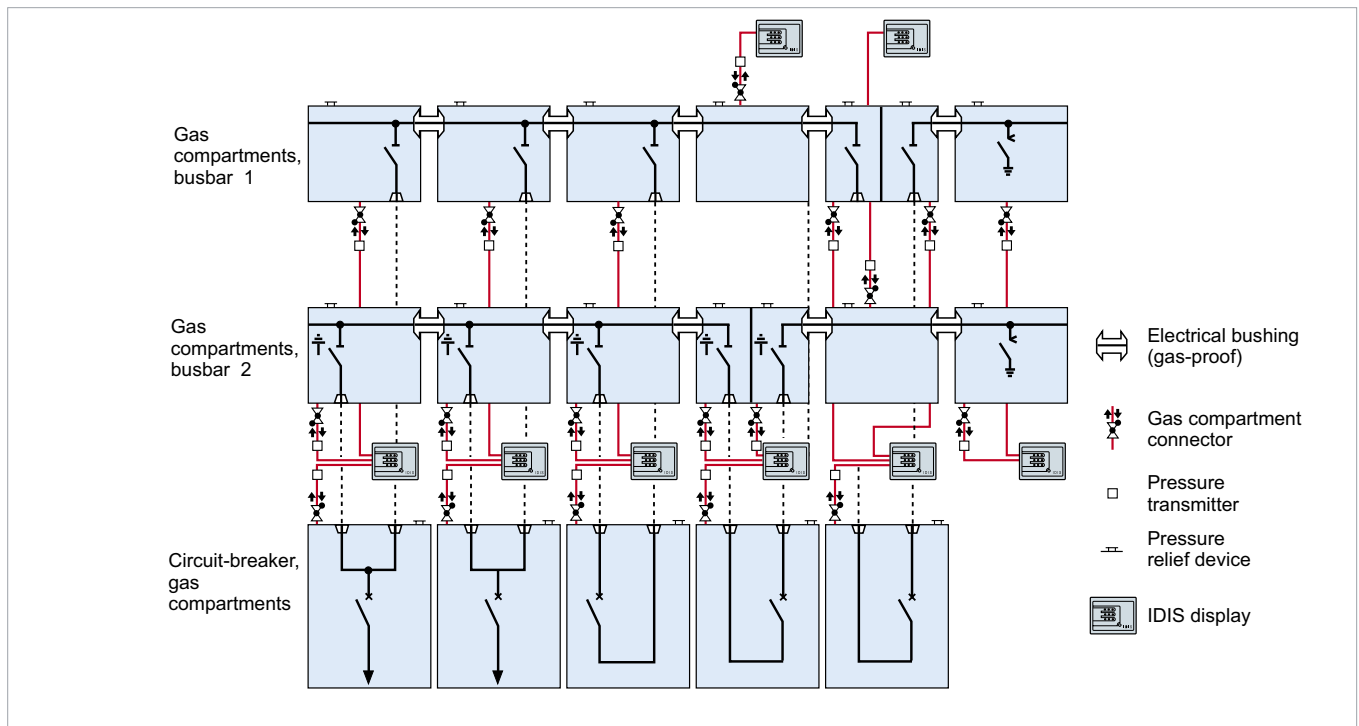

Example: GHA double busbar



Current transformer in outgoing feeder area

The current transformers are of toroidal-core transformer design and are mounted on the single-pole, externally earthed bushings in the area of the cable outgoing feeder. The switchgear-specific conductor of the bushings forms the primary conductor: The toroidal-core current transformers are designed as free of cast resin parts subject to dielectric stress.

Up to 5 transformer cores per conductor can be accommodated, taking the maximum admissible transformer stack-ing height into account. The toroidalcore current transformers in the outgoing feeder block are arranged outside of the gas-filled compartments, for the cable connection system

- Outer cone-type attached onto the extended cone-type couplers as three-phase toroidal-core current transformer
 - up to 24 kV and max. 1250 A
ID 81 mm, OD 81 mm, stacking height max. 140 mm.
 - up to 36 kV and max. 1250 A
ID 81 mm, OD 188 mm, stacking height max. 250 mm.
 - attached onto the 2 outer cone-type couplers / conductors up to 36 kV and currents > 1250 A up to 2500 A are, for each conductor, toroidalcore current transformers with an oval core and a stacking height of max. 225 mm
- Toroidal-core current transformers for billing metering. A measuring core of the toroidal-core current transformer kit can be implemented for each conductor in a calibratable or calibrated design for billing metering. In combination with a calibratable/calibrated winding in the voltage transformers of the outgoing feeder block or on the busbar, billing metering can be implemented, e.g. in accordance with German regulations.

Technical data

Characteristics		
Maximum voltage for operating equipment Um in kV	0.72	
Rated short-time power frequency withstand voltage in kV	3	
Rated frequency	50/60 Hz	
Continuous thermal current	1,0 x In (1.2 x In on request)	
Rated thermal short-time current	max. 40 kA, max. 3 s	
Primary rated current	50 up to 2500 A	
Secondary rated current	1A (5A a request)	
Number of cores	max. 3, higher number on request	
Core data (depending on primary rated current) Performance Class / overcurrent factor	Measuring core 2.5 up to 10 VA 0.2 up to 1 / M10	Protection core 2.5 up to 30 VA 5 up to 10 / P10 up to P30
Admissible ambient temperature		
Standards	IEC 61869-2	
<i>Calibratable/calibrated winding for billing metering possible on request</i>		

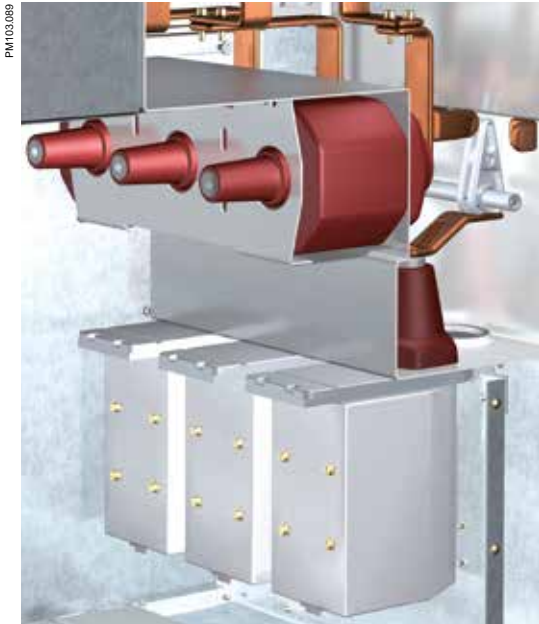

Voltage transformer in cable compartment with disconnecting device (illustration: gas-filled compartment open)

Voltage transformers

The inductive voltage transformers are

- Single-pole isolated voltage transformers
- Fully shrouded and earthed in accordance with system
- In addition to main winding, additional auxiliary winding possible for earth fault detection (optional)
 - Design with one tap in the main winding for switchability to two different rated voltages of the high-voltage system possible (optional)
 - Separate windings in calibratable or calibrated design for billing metering (optionally) possible
- Available with integrated high-voltage fuses (optional)

Attachment of the voltage transformers

- Cable side VT are installed in metal enclosed compartment
- Busbar VT are installed on the top of the cubicle
- Disconnecting device (optionally) possible on high-voltage side
 - High-voltage cable test without removal of the voltage transformers
 - Speedy recommissioning of a GHA switchgear cubicle in the unlikely event of a fault on the voltage transformer
 - Very safe working conditions and short downtimes should the voltage transformers need to be replaced
 - Disconnecting devices in gas-filled compartment with switching positions "ON" and "OFF – transformer earthed"
- Arranged outside the gas-filled compartment
- Adaptation on the high-voltage side and mechanically via inner cone-type bushings
- Removable without intervention in the gas-filled compartment
- Actuation on the front of the switchgear and control gear
- Indication of the switch position on the front of the switchgear
 - Together for all three conductors
 - Locking knob in the defined end positions
 - Possibility of attaching a padlock

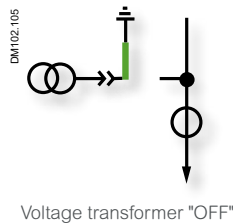
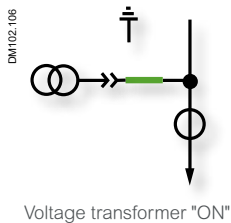

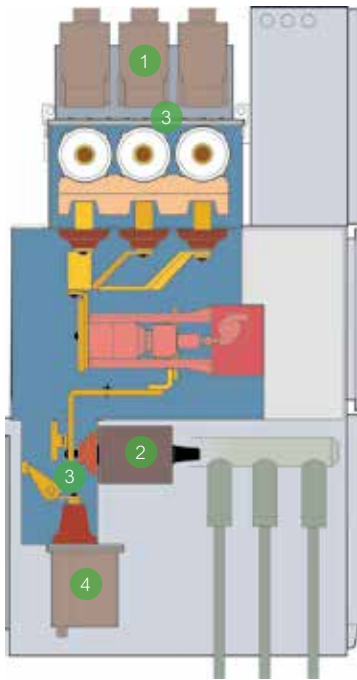

- 1 Voltage transformer module on busbar
- 2 Toroidal-core current transformer
- 3 Disconnecting device for voltage transformer
- 4 Voltage transformer in outgoing feeder block

Voltage transformers arrangement for single busbar cubicle

Technical data

Toroidal-core current transformer	Metal-enclosed, single-pole voltage transformers			
Operating voltage (max.) (kV)	12	24	36	40.5
Primary voltage (kV)	5.0/√3	13.8/√3	25.0/√3	34.5/√3
	6.0/√3	15.0/√3	25.8/√3	35.0/√3
	6.6/√3	17.5/√3	30.0/√3	38.0/√3
	7.2/√3	20.0/√3	33.0/√3	
	10.0/√3	22.0/√3	34.5/√3	
	11.0/√3			
Secondary voltage (V)		100/√3	100/√3	100/√3
		110/√3	110/√3	110/√3
Auxiliary winding for earth fault detection (V)	100/3	100/3	100/3	100/3
Secondary, thermal limit current of measuring winding (A)	7	7	7	7
	(12)	(12)	(12)	(12)
Rated voltage factor UN/8h	1.9	1.9	1.9	1.9
Rated continuing current/8h (A)	6	6	6	6
Accuracy class	0.2-0.5-1	0.2-0.5-1	0.2-0.5-1	0.2-0.5-1
Performance (VA)	20-60-120	20-60-120	20-60-120	120
	(30-90-180)	(30-90-180)	(30-100-200)	200
Standards	IEC 61869-3			

Calibratable/calibrated winding for billing metering possible on request

Busbar fixtures

Busbar attachments for single busbar switchgear



Disconnectable voltage transformer, variant 1



Disconnectable voltage transformer, variant 2



Busbar earthing switch



Busbar surge arrester, variant 1



Busbar surge arrester, variant 2

Cable connections

Inner /Outer cones

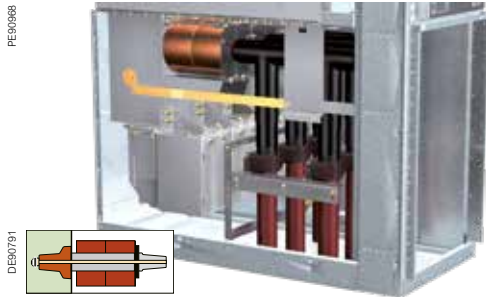

Outer cone-type bushings up to 36 kV, < 1250 A
(1 outer cone-type/conductor)

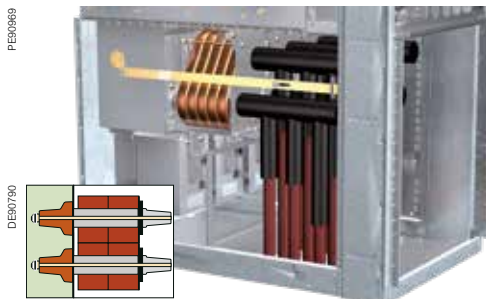

Outer cone-type bushings up to 36 kV, > 1250 A
(2 outer cone-type/conductor)

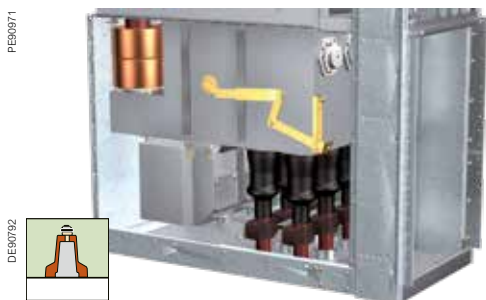

Inner cone-type bushings up to 40.5 kV - 2x size 2
(800 A) or size 3 (1250 A) with flange-mounted voltage transformers



Inner cone-type bushings up to 40.5 kV, multiple cable connections (1x to 4x) size 2 (800 A) or size 3 (1250 A) with flange-mounted voltage transformers

Versatile cable connectors

The metal-enclosed cable connection compartment is easily accessible on the switchgear front, and suitable for a great variety of cable connection techniques. For the GHA, the following cable connection systems can be used at choice:

For outer cone-type bushings Type C in accordance with EN 50181, up to incl. 40.5 kV.

This is the GHA standard version for branch circuit currents up to 2500 A.

Outer-cone bushings are used with T-shaped (also known as Tee-plug or T-connector) plug-in terminations.

- Rated current < 1250 A : one outer-cone C-bushing per phase (up to 3 T-shaped connectors)
- Rated current > 1250 A: two outer-cone C-bushings per phase (up to 6 T-shaped connectors)
- Rated current 1600 A and 2000 A: one outer-cone F-bushing per phase (up to 3 T-shaped connectors)

Cables up to 800 mm² and system compatible surge arresters can also be used.

In case of models with 2 outer cone-type couplers/conductor, it is important always to mount an identical number of cable connectors and identical cable types and cable cross sections on both coupler parts.

Cable testing is effected from the GHA switchgear front by means of the test adapters mounted onto the cable Tee plugs. Compliance with the specifications by the manufacturers of cable connectors, Tee screw-type plugs, partially insulated terminal adapters and surge arresters is mandatory for selection and assembly. Regarding the required current-carrying capacity over 630 A, the use of suitable Tee screw-type plugs deserves special attention.

Cables > 500 mm² must be clamped additionally underneath the switchgear.

For inner-cone-type plug-in system in accordance with EN 50181, up to 40.5 kV.

For the selected cable types and cross sections, there are appropriate inner cone-type bushings available for cable connector terminal types 1 to 3 and the modified connector, terminal type Connex size 4, manufacturer: Pfisterer.

Up to four inner cone-type bushings per conductor can be installed in the floor pan of the GHA switchgear, depending on the inner-cone connection type. One bushing per phase is required for inner cone-type surge arresters.

Bus terminals

In the outgoing feeder block, solids-insulated bus terminals can be connected with potentially earthed round bars. Connection and disassembly of the bars is effected without gas handling.

- Up to incl. 1600 A, connection is effected via inner cones size 3, for >1600 A with size 4.
- Inner cone-type coupler types
- 800 A (size 2)
- 1250 A (size 3)
- 2500 A (size 4)

PE90972



Cable test in case of inner cone-type coupler with test cable

PE90973

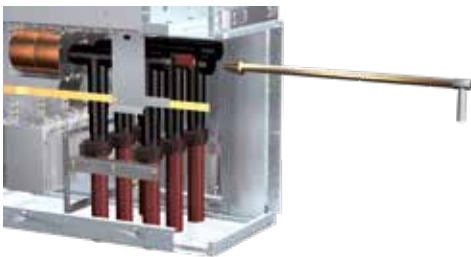

Cable test in case of outer cone-type coupler with test adapter

Safe cable testing

(For details, please refer to the Operating Manual)

The voltage test of all cables connected to the GHA switchgear can be performed without any problems and safely from the front side with the busbar and the adjacent panels in energized condition.

In the switch position "Outgoing feeder earthed", the cable compartment cover is removed. The cable test adapters are mounted and the external cable test equipment is connected. The cable test as such is performed with the vacuum circuit-breaker in position OFF and the three-position disconnecter in position "Earth ON". This special case can be configured by means of the operating crank in the actuating port for the outgoing earthing switch.

The switch condition can be determined via the mechanical switch position indicators with the combination:

- Disconnecting function: OFF position
- Earthing function: no end position indication + inserted actuating lever cannot be removed + circuit-breaker in "OFF" position. Removal of the cable test equipment and the establishment of the voltage-proof state of the outgoing feeder after termination of the testing work is performed with the disconnecter in earthed condition "Earthing ON" + circuit-breaker "ON".

With the voltage transformer disconnecting device mounted upstream on the high-voltage side, the voltage test can be performed easily and safely in the position „Transformer earthed“ without disassembly of the voltage transformers or of further switchgear components.

Installation & Connection

Installation & Connection

Room planning	100
Single busbars	100
Double busbars	101
Basic dimensions	102
Floor openings	104

Shipping instructions	112
------------------------------	------------

Outer cone-type cable connection combinations	114
--	------------

Room planning

Single busbar

Accessible on the front and on the side (A-FL)

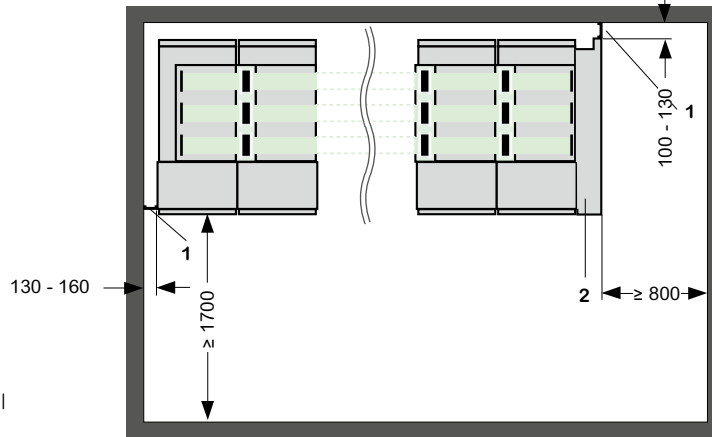

- 1 Cover to wall
- 2 Side wall

Accessible on the front, sides and at the rear (A-FLR)

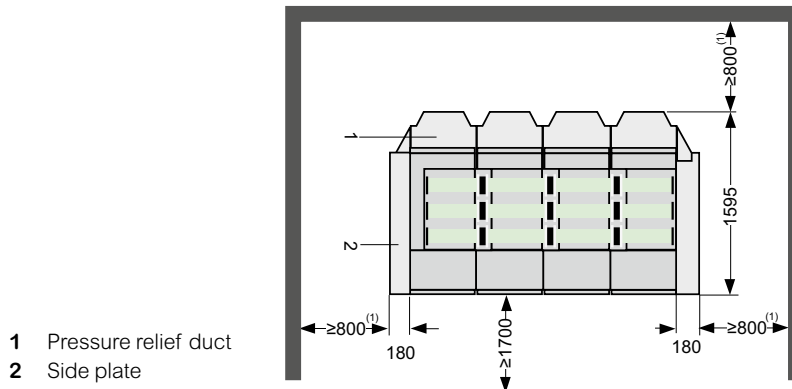

- 1 Pressure relief duct
- 2 Side plate

(1) Smaller distances on request

Room planning

Double busbar

Accessible on the front and on the side (A-FL)

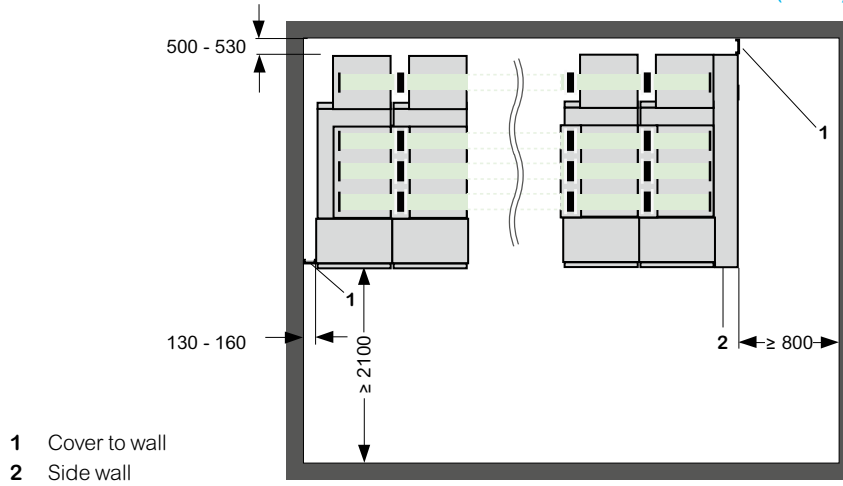

Accessible on the front, sides and at the rear (A-FLR)

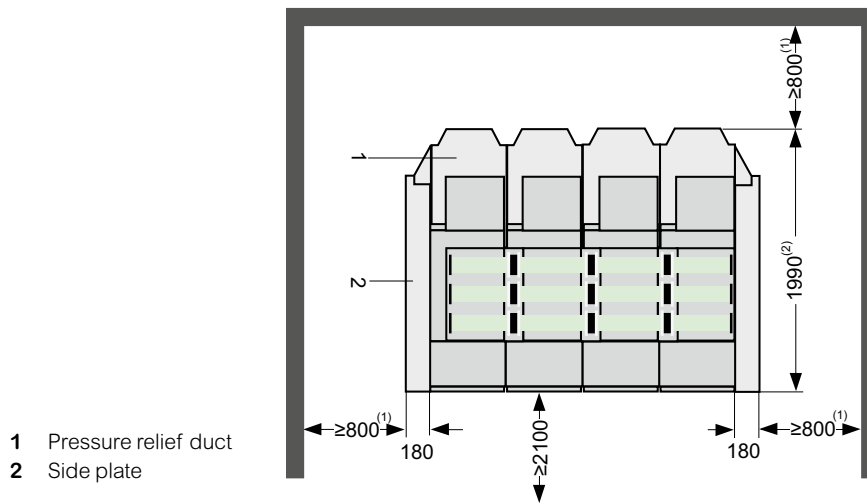

(1) Smaller distances on request
(2) Bus section coupler (2500 A) on demand

Room planning

Basic dimensions - Single busbar switchgear

The basic design includes low-voltage cabinets of various heights and side plate attachments on the accessible switchgear components.

Note: the minimum cable bending radius must be taken into account for the height of the cable basement.

A-FL

Height of low-voltage cabinet: 800 mm

Height of low-voltage cabinet: 1200 mm

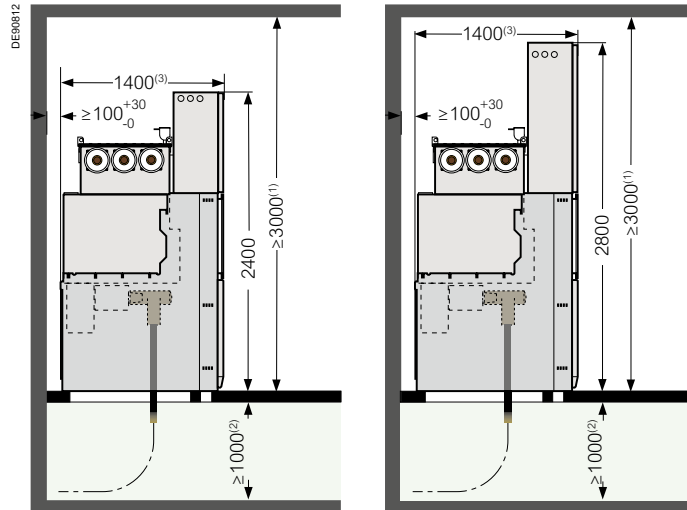

- (1) Lower height to be confirmed on request
- (2) Depending on cable cross section and cable connection types
- (3) Depth: depends on the type of used cubicles

A-FLR with exhaust inside the room

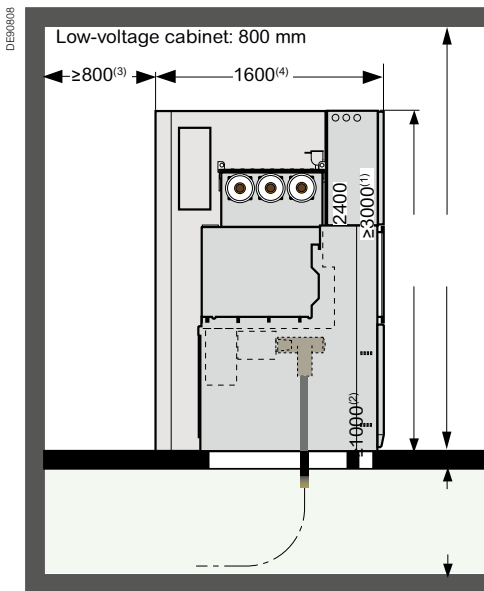

A-FLR with exhaust outside the room

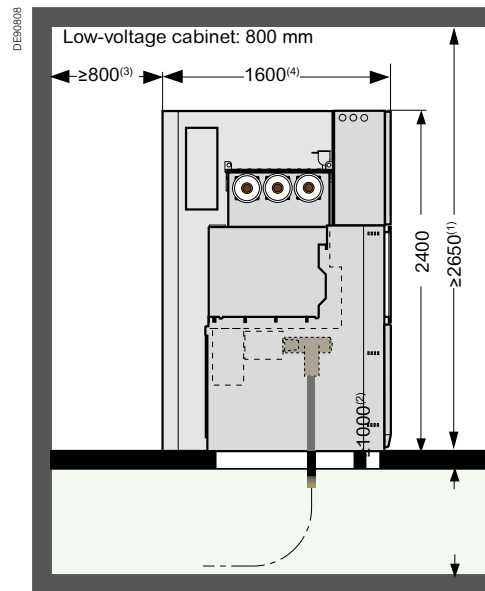

- (1) Room height to comply with the IAC qualification in acc. with IEC/EN 62 271-200
- (2) Depending on cable cross section and cable connection types
- (3) Smaller distances on request
- (4) Depth: depends on the type of used cubicles

Room planning

Basic dimensions - Double busbar switchgear

The basic design includes low-voltage cabinets of various heights and side plate attachments on the accessible switchgear components.

Note: the minimum cable bending radius must be taken into account for the height of the cable basement.

A-FL

Height of low-voltage cabinet: 800 mm

Height of low-voltage cabinet: 1200 mm

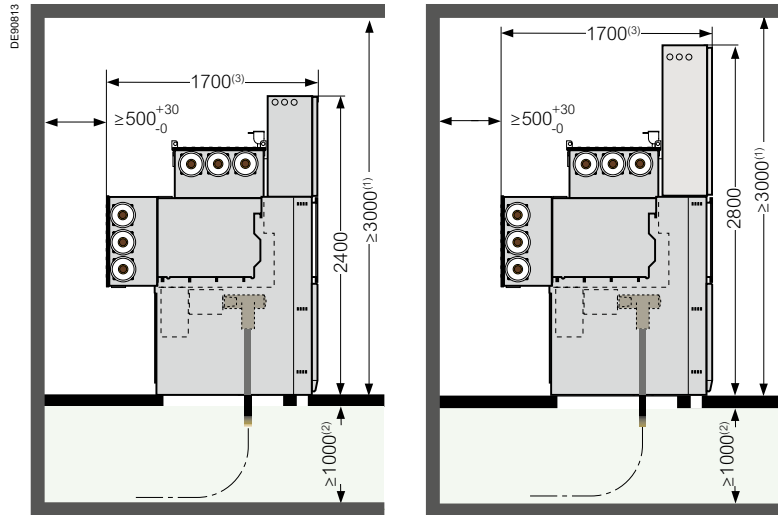

- (1) Lower height to be confirmed on request
- (2) Depending on cable cross section and cable connection types
- (3) Depth: depends on the type of used cubicles

A-FLR with exhaust inside the room

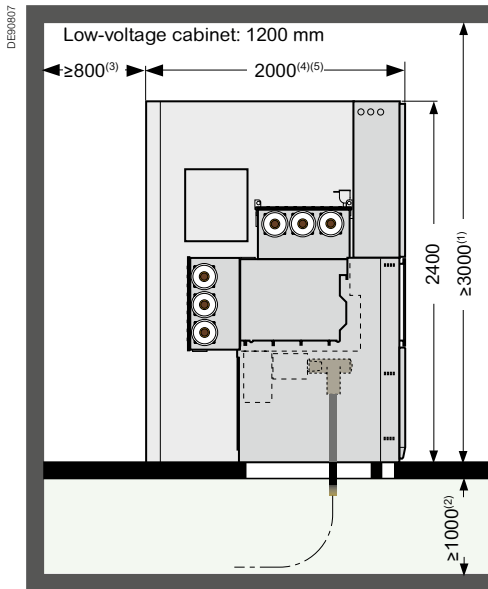

A-FLR with exhaust outside the room

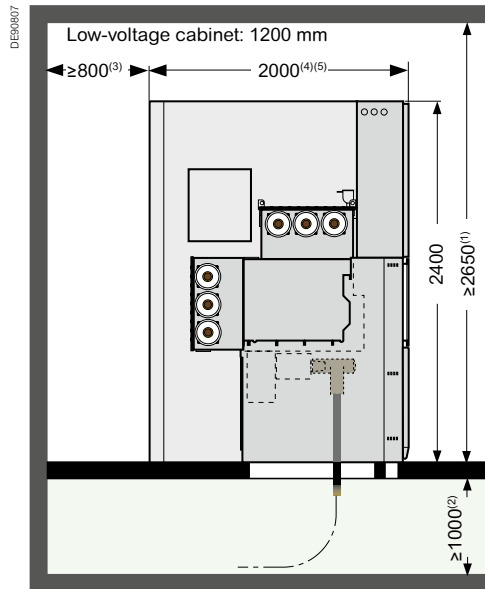

- (1) Room height to comply with the IAC qualification in acc. with IEC/EN 62 271-200
- (2) Depending on cable cross section and cable connection types
- (3) Smaller distances on request
- (4) Depth: depends on the type of used cubicles
- (5) Bus section coupler (2500 A) on demand

Room planning

Floor openings

Center panels without pressure relief duct SBB

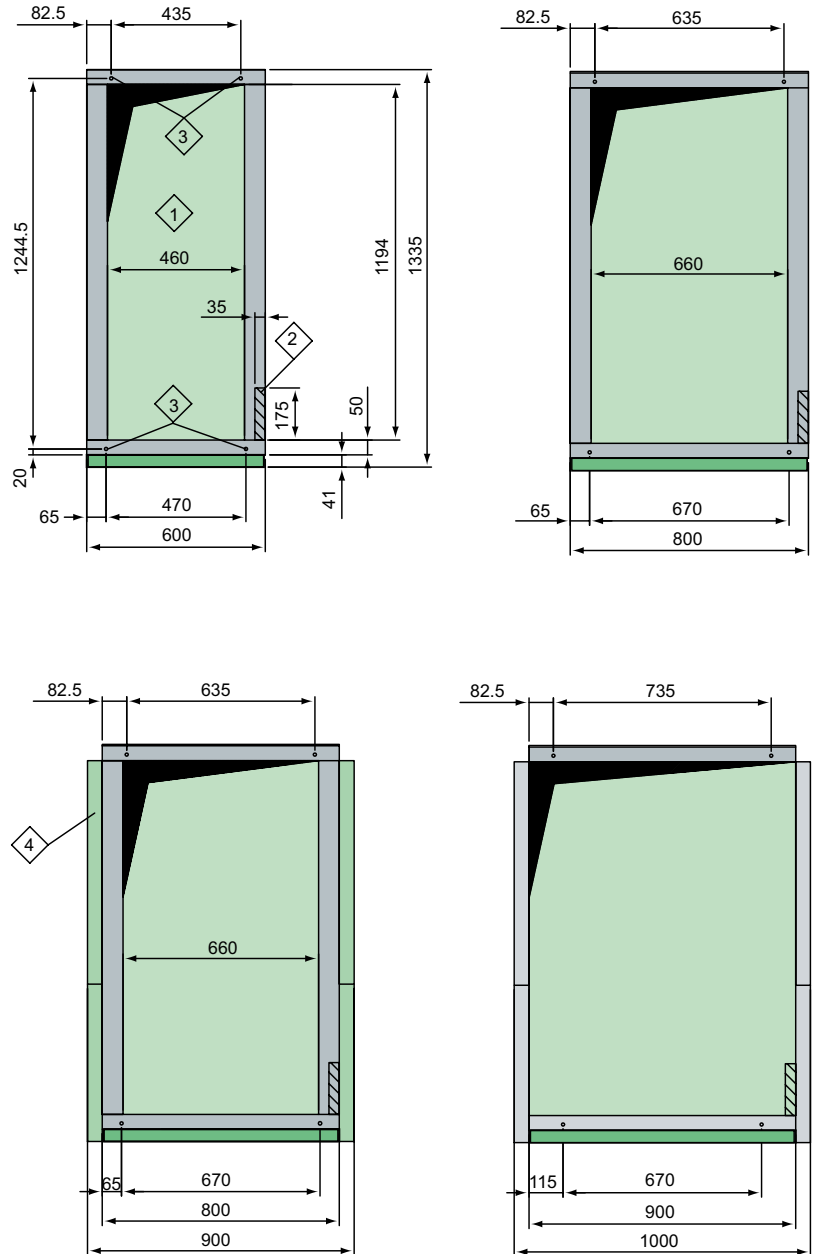

- 1 Ceiling duct for high-voltage terminals
- 2 Ceiling duct for low-voltage connector
- 3 Panel securing points
- 4 Cooler attachments

Room planning

Floor openings

Center panels with pressure relief duct SBB

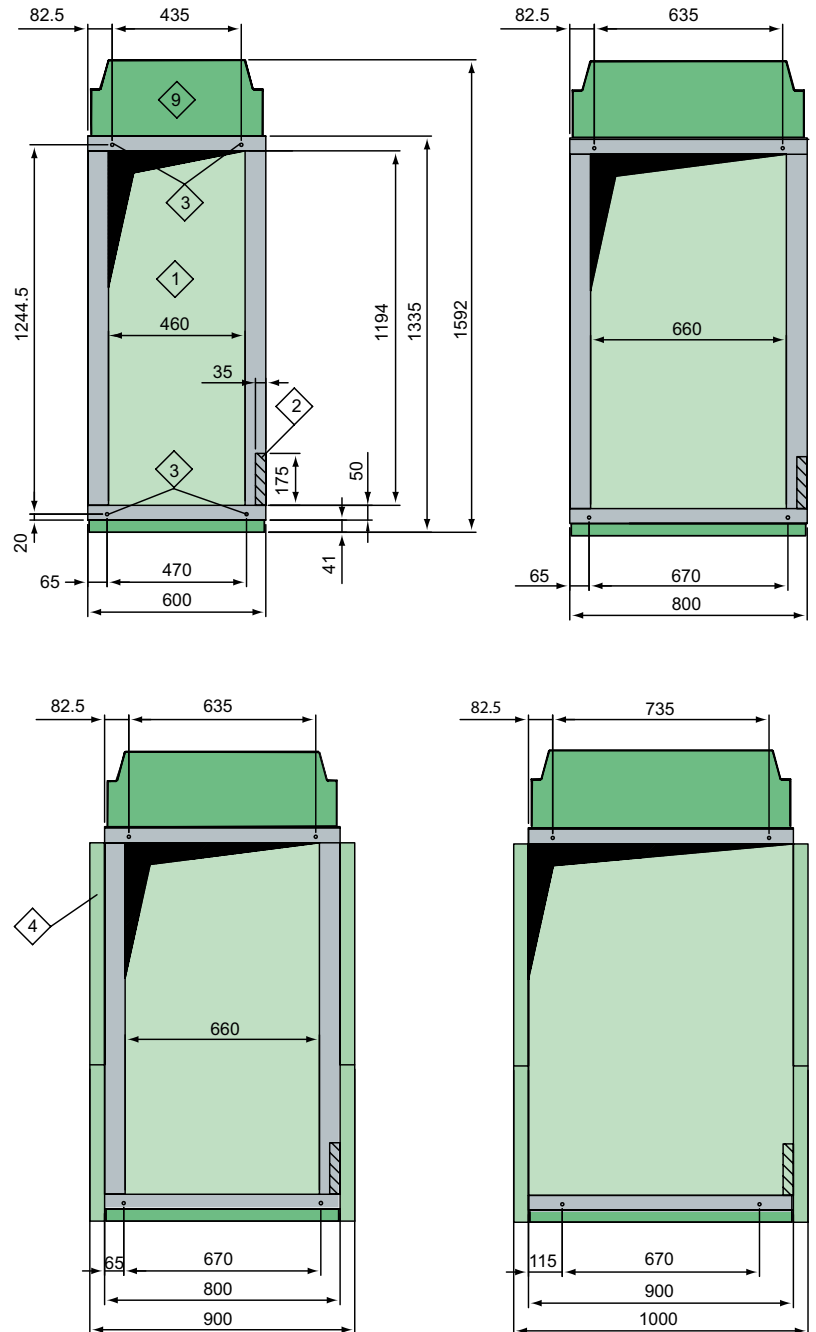

- 1 Ceiling duct for high-voltage terminals
- 2 Ceiling duct for low-voltage connector
- 3 Panel securing points
- 4 Cooler attachments
- 9 Pressure relief duct

Room planning

Floor openings

Center panels without pressure relief duct DBB

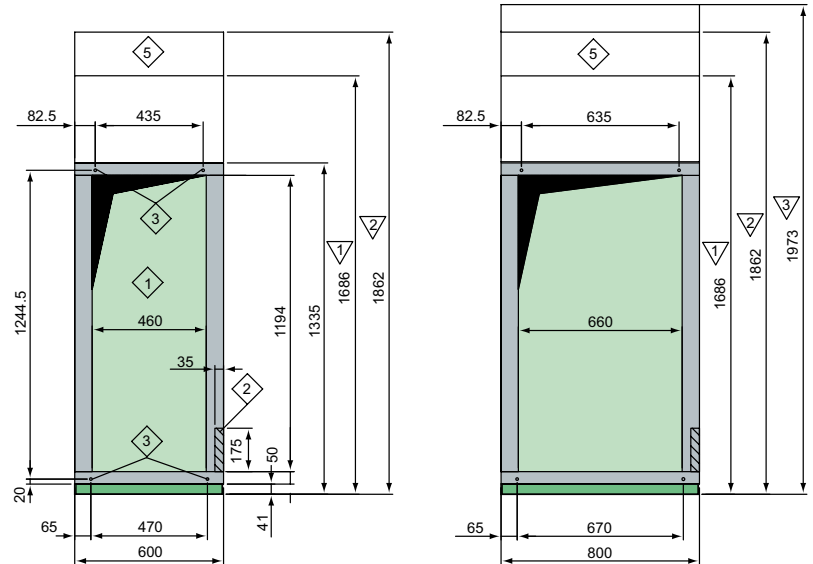

1 Branch- circuit panel 800 A - 1250 A Bus riser 800 A - 1250 A Bus coupler 800 A - 1600 A
2 Bus coupler 2000 A

1 Branch- circuit panel 1600 A Bus riser 1600 A Bus section coupler 800 A - 1600 A
2 Branch- circuit panel 2000 A Bus riser 2000 A
3 Bus section coupler 2000 A

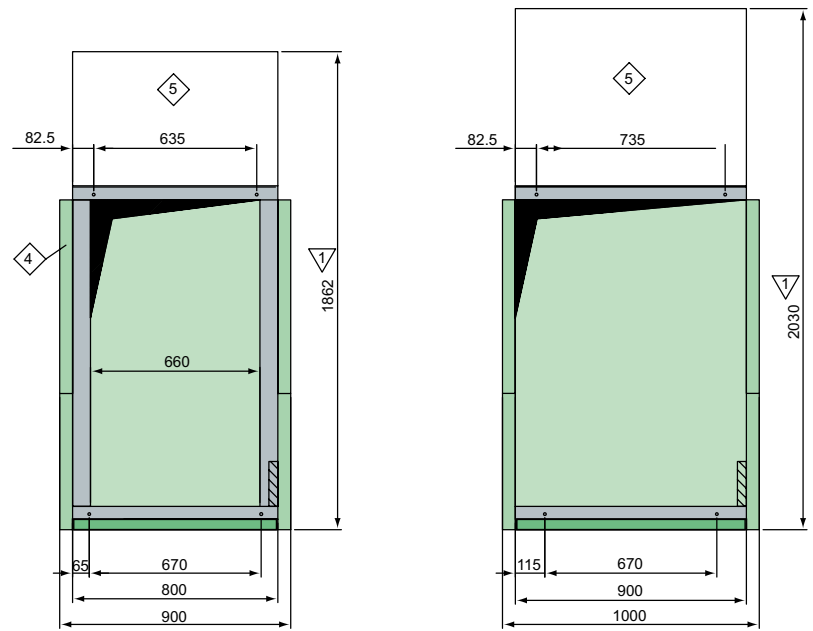

1 Branch-circuit panel 2500 A Bus riser 2500 A Bus coupler 2500 A

1 Bus section coupler 2500 A

- 1 Ceiling duct for high-voltage terminals
- 2 Ceiling duct for low-voltage connector
- 3 Panel securing points
- 4 Cooler attachments
- 5 Rear busbar tank in case of double busbar panels

Room planning

Floor openings

Center panels with pressure relief duct DBB

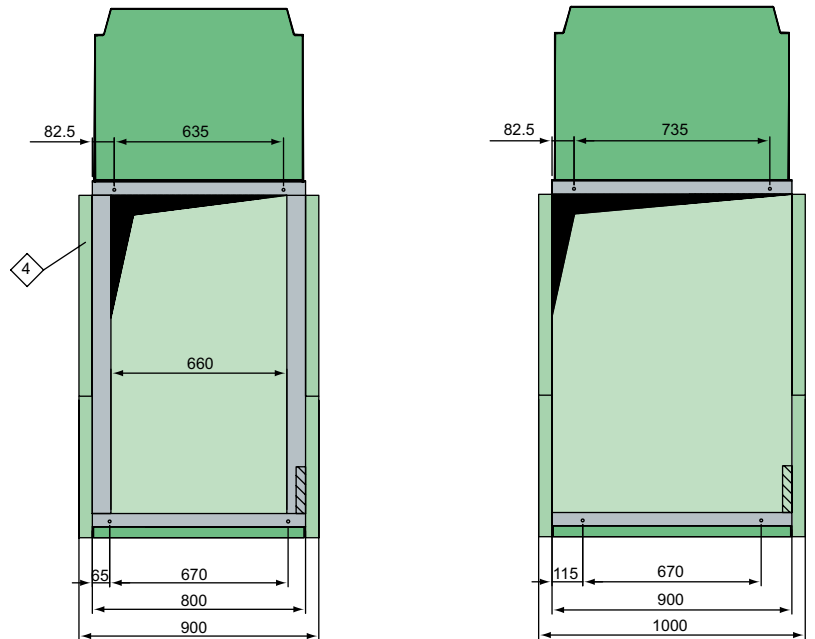
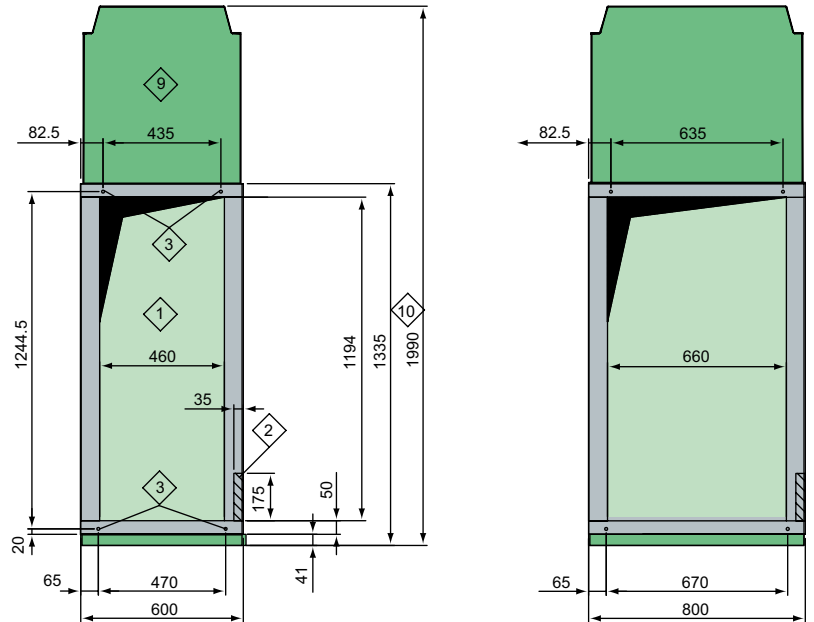

- 1 Ceiling duct for high-voltage terminals
- 2 Ceiling duct for low-voltage connector
- 3 Panel securing points
- 4 Cooler attachments
- 9 Pressure relief duct
- 10 Bus section coupler (2500 A) on demand

Room planning

Floor openings

End panels without pressure relief duct SBB

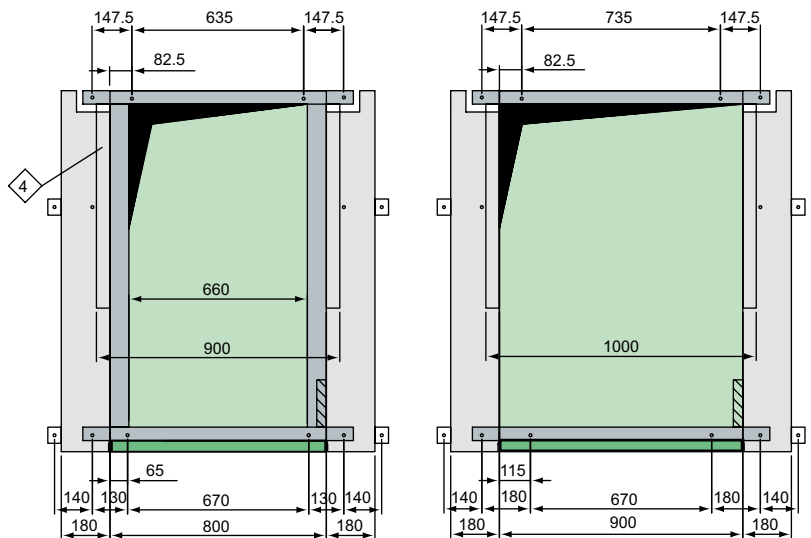
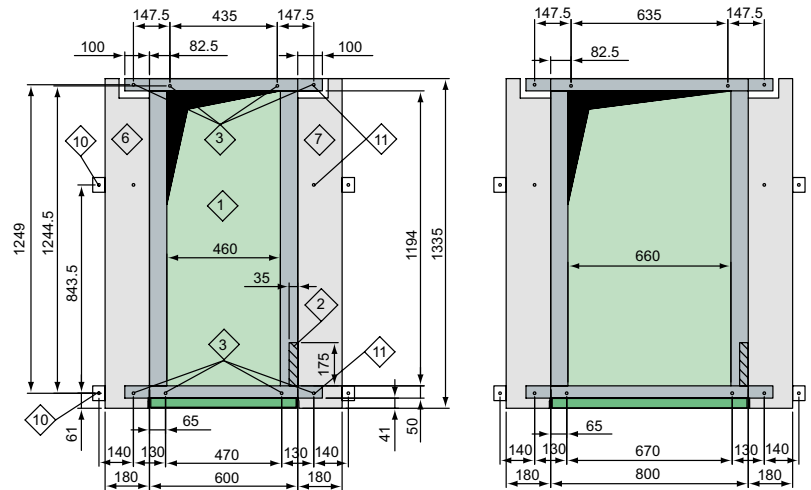

- 1 Ceiling duct for high-voltage terminals
- 2 Ceiling duct for low-voltage connector
- 3 Panel securing points
- 4 Cooler attachments
- 6 Left-hand side plate
- 7 Right-hand side plate
- 9 Pressure relief duct
- 10 for fastening on the floor in case of installation with a wall clearance of 100 mm
- 11 for fastening on the base frame in case of installation with a wall clearance > 100 mm

Room planning

Floor openings

End panels with pressure relief duct SBB

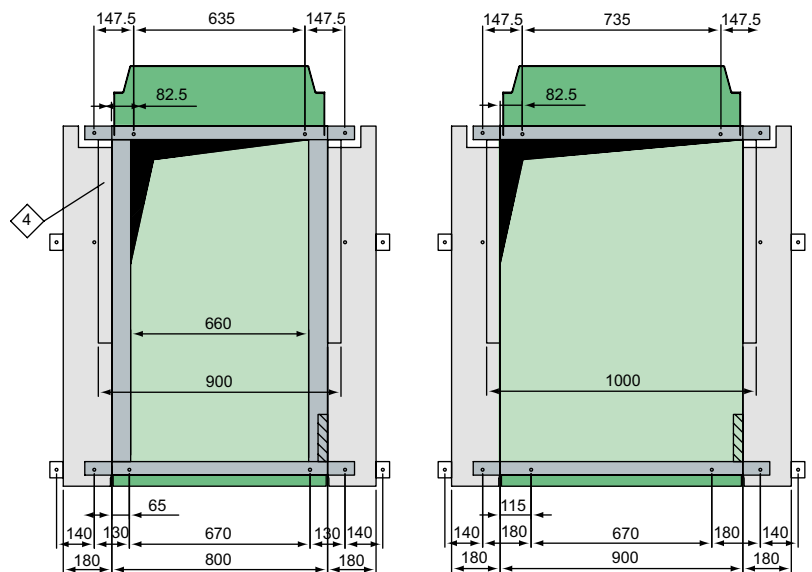
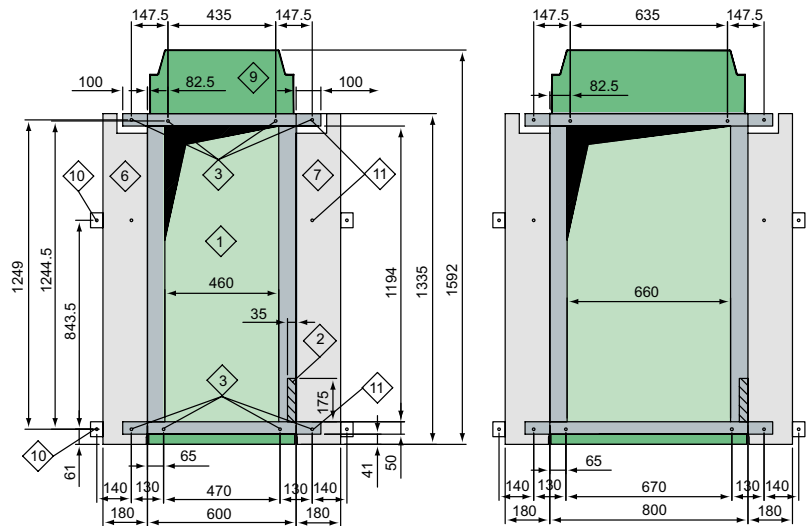

- 1 Ceiling duct for high-voltage terminals
- 2 Ceiling duct for low-voltage connector
- 3 Panel securing points
- 4 Cooler attachments
- 6 Left-hand side plate
- 7 Right-hand side plate
- 9 Pressure relief duct
- 10 for fastening on the floor in case of installation with a wall clearance of 100 mm
- 11 for fastening on the base frame in case of installation with a wall clearance > 100 mm

Room planning

Floor openings

End panels without pressure relief duct DBB

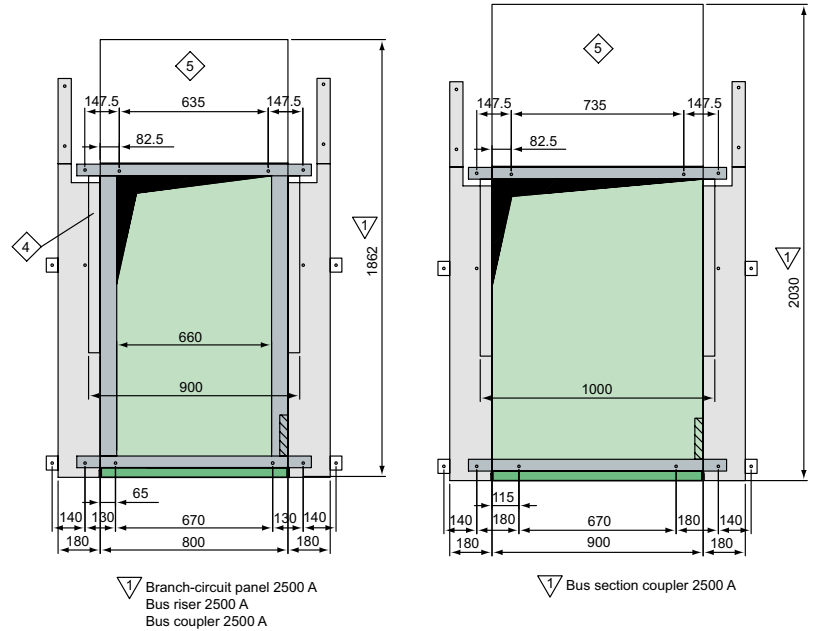
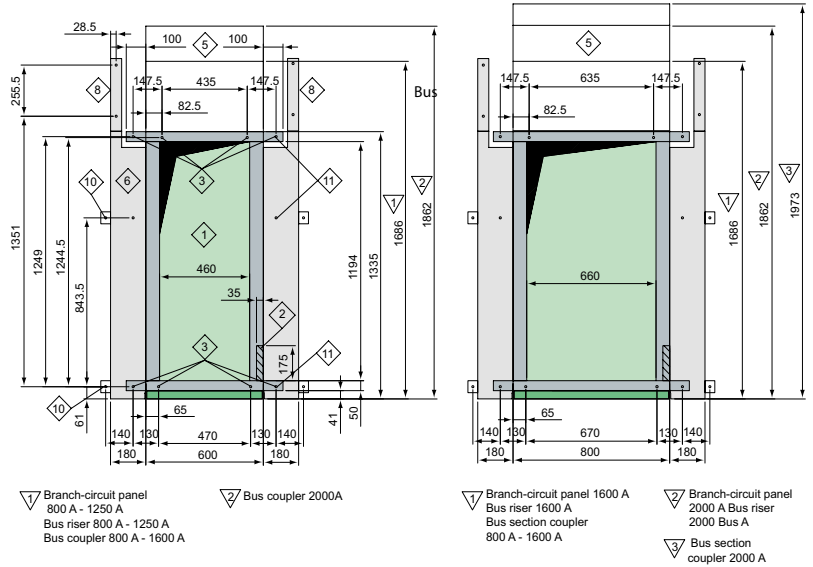

- 1 Ceiling duct for high-voltage terminals
- 2 Ceiling duct for low-voltage connector
- 3 Panel securing points
- 4 Cooler attachments
- 5 Rear busbar tank in case of double busbar panels
- 6 Left-hand side plate
- 7 Right-hand side plate
- 8 Side plate extension for double busbar switchgear units
- 9 Pressure relief duct
- 10 for fastening on the floor in case of installation with a wall clearance of 100 mm
- 11 for fastening on the base frame in case of installation with a wall clearance > 100 mm

Room planning

Floor openings

End panels with pressure relief duct DBB

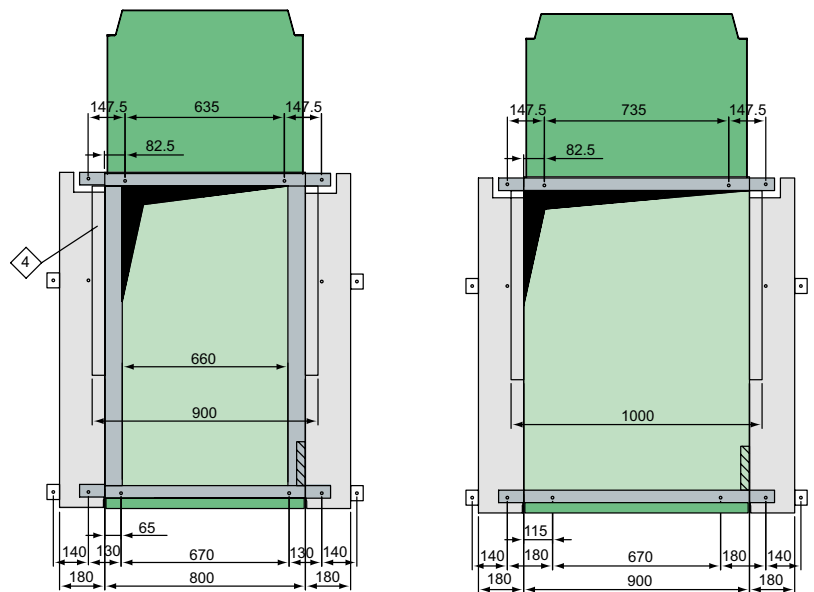
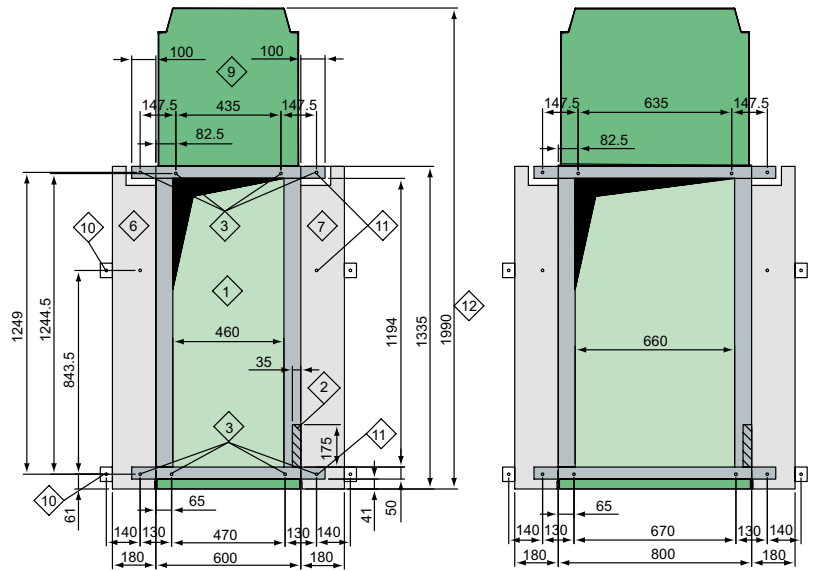

- 1 Ceiling duct for high-voltage terminals
- 2 Ceiling duct for low-voltage connector
- 3 Panel securing points
- 4 Cooler attachments
- 5 Rear busbar tank in case of double busbar panels
- 6 Left-hand side plate
- 7 Right-hand side plate
- 9 Pressure relief duct
- 10 for fastening on the floor in case of installation with a wall clearance of 100 mm
- 11 for fastening on the base frame in case of installation with a wall clearance > 100 mm
- 12 Bus section coupler (2500 A) on demand

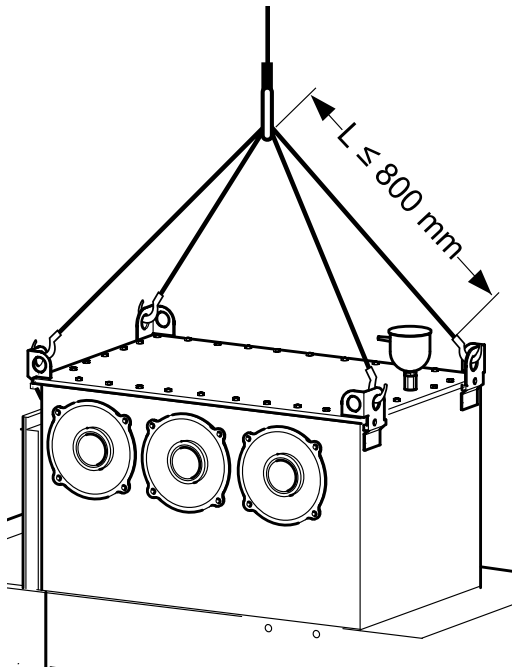

Transporting the switchgear unit

When transporting the switchgear unit, it must be ensured that the transport units do not slip or tilt (if necessary, nail transport pallet down to the loading surface). Re-use the original packaging to store parts which have been un-packed for inspection.

Packaging of the switchgear

- If packed for truck transport, the switchgear unit is delivered on a pallet with PE protective film.
- For sea-worthy transport, the units are packed in sealed aluminium film with desiccant and in a closed case with tightly closed wooden base (also for container transport).
- In case of air transport, the switchgear unit is packaged in a wooden crate with closed wooden base and with PE film as dust protection or in a wooden case, also with closed wooden base.

Transport to the site of installation

Store under conditions admissible for switchgear operation. Avoid condensation.

During transport to the site of installation (for details, refer to the Assembly Instructions), it must be taken into account that the main weight is located in the top area of the switch-gear – “top-heavy”.

Transport using a forklift truck: Only transport the switchgear on a pallet.

Attention – “top-heavy”!

Transport without pallet: The crane mounting harness must be hooked into the jack rings of the switchgear.

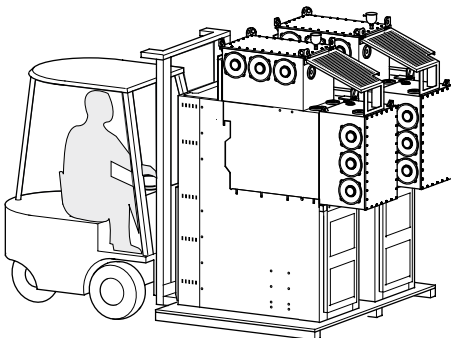
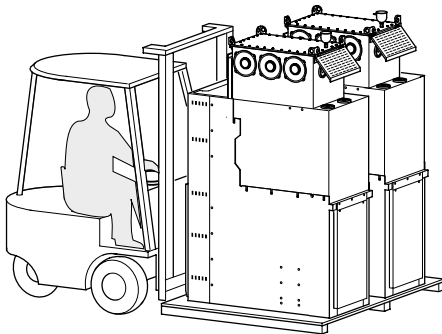

Outer cone-type cable connection combinations

Tee plug and surge arrester

<1250 - 1 outer cone

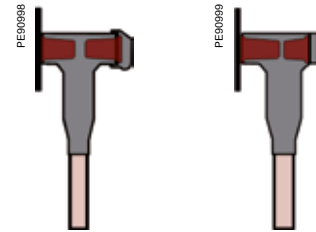
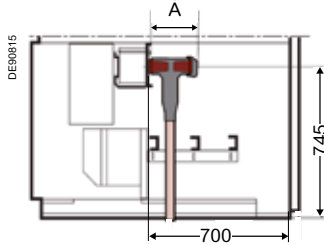

No.	Number of cables per panel and phase ⁽²⁾	Rated voltage kV	Supplier	Phase cross section mm ²	Insulation	Tee plug	Tee plug compact
1	1	≤12	Euromold/Nexans	25-300	EPDM		430TB
2	1	≤12	Euromold/Nexans	400-630	EPDM		484TB
3	1	≤24	Euromold/Nexans	25-300	EPDM		K430TB
4	1	≤24	Euromold/Nexans	400-630	EPDM		K484TB
5	1	≤36	Euromold/Nexans	25-240	EPDM		M430TB
6	1	≤36	Euromold/Nexans	300-630	EPDM		M484TB
7	2	≤12	Euromold/Nexans	25-300	EPDM		1x 430TB
8	2	≤12	Euromold/Nexans	25-300	EPDM		2x 430TB
9	2	≤12	Euromold/Nexans	400-630	EPDM		1x 484TB
10	2	≤24	Euromold/Nexans	25-300	EPDM		1x K430TB
11	2	≤24	Euromold/Nexans	25-300	EPDM		2x K 430TB
12	2	≤24	Euromold/Nexans	400-630	EPDM		1x K484TB
13	2	≤36	Euromold/Nexans	25-300	EPDM		1x M430TB
14	2	≤36	Euromold/Nexans	300-630	EPDM		1x M484TB
15	3	≤12	Euromold/Nexans	25-300	EPDM		1x 430TB
16	3	≤24	Euromold/Nexans	25-300	EPDM		1x K430TB
17	3	≤36	Euromold/Nexans	25-240	EPDM		1x M430TB
18	3	≤12	Euromold/Nexans	400-630	EPDM		1x 484TB
19	3	≤24	Euromold/Nexans	400-630	EPDM		1x K484TB
20	3	≤36	Euromold/Nexans	300-630	EPDM		1x M484TB
21	1	≤12	nkt cables	25-300	Silicone	-	1x CB 12-630
22	1	≤24	nkt cables	25-300	Silicone	-	1x CB 24-630
23	1	≤12	nkt cables	185-500	Silicone	-	1x CB 24-1250/2
24	1	≤24	nkt cables	95-500	Silicone	-	1x CB 24-1250/2
25	1	≤24	nkt cables	400-630 / 800AL RE	Silicone	-	1x CB 36-630 (1250)
26	1	≤36	nkt cables	25-300	Silicone	-	1x CB 36-630
27	1	≤36	nkt cables	400-630 / 800AL RE	Silicone	-	1x CB 36-630 (1250)
28	2	≤12	nkt cables	25-300	Silicone	-	1x CB 12-630
29	2	≤12	nkt cables	185-500	Silicone	-	1x CB 24-1250/2
30	2	≤12	nkt cables	25-300	Silicone	-	2x CB 12-630
31	2	≤24	nkt cables	25-300	Silicone	-	1x CB 24-630
32	2	≤24	nkt cables	95-500	Silicone	-	1x CB 24-1250/2
33	2	≤24	nkt cables	25-300	Silicone	-	2x CB 24-630
34	2	≤24	nkt cables	400-630 / 800AL RE	Silicone	-	2x CB 36-630 (1250)
35	2	≤24	nkt cables	400-630 / 800AL RE	Silicone	-	1x CB 36-630 (1250)
36	2	≤36	nkt cables	25-300	Silicone	-	1x CB 36-630
37	2	≤36	nkt cables	25-300	Silicone	-	2x CB 36-630
38	2	≤36	nkt cables	400-630 / 800AL RE	Silicone	-	2x CB 36-630 (1250)
39	2	≤36	nkt cables	400-630 / 800AL RE	Silicone	-	1x CB 36-630 (1250)
40	3	≤12	nkt cables	25-300	Silicone	-	1x CB 12-630

⁽¹⁾A detailed clarification of the surge arresters is required order-specifically with the manufacturer in question depending on the neutral-point connection and system configuration concerned

⁽²⁾Three-conductor cables available on request (connectors and accessories to be clarified with the connector supplier concerned)

Outer cone-type cable connection combinations

Tee plug and surge arrester

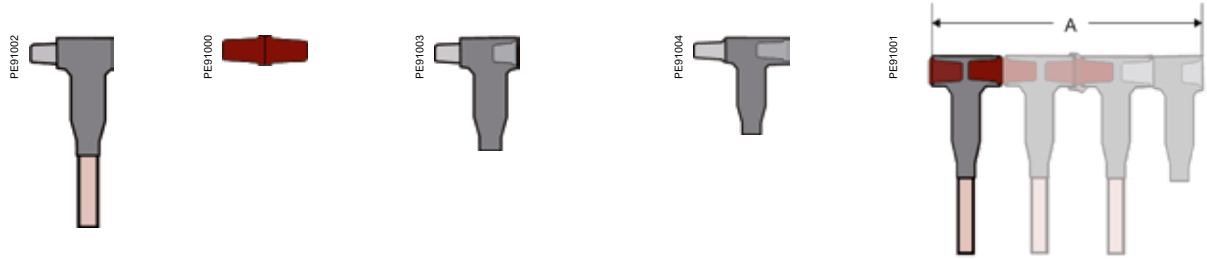

No.	Connector plug	Coupler	Surge arrester ⁽¹⁾		Length A max. 700 mm			
			Version 1	Version 2	without surge arrester	Version 1	Version 2	
1				300SA		185		290
2				800SA		185		290
3				300SA		185		290
4				800SA		185		290
5				300SA		185		290
6				800SA		185		290
7	1x 300PB			300SA		290		395
8		430CP		300SA		375		480
9	1x 804PB			800SA		290		400
10	1x K300PB			300SA		290		395
11		K430CP		300SA		394		501
12	1x K804PB			800SA		290		400
13	1x M300PB			300SA		290		395
14	1x M804PB			800SA		290		400
15	2x 300PB			300PB		395		500
16	2x K300PB			300PB		395		500
17	2x M300PB			300SA		395		500
18	2x 804TB			800SA		400		510
19	2x K804TB			800SA		400		510
20	2x M804TB			800SA		400		510
21	-	-	CSA 12	-		190	290	-
22	-	-	CSA 24	-		190	290	-
23	-	-	CSA 12	-		190	290	-
24	-	-	CSA 24	-		190	290	-
25	-	-	CSA 24	-		190	290	-
26	-	-	CSA 36	-		190	300	-
27	-	-	CSA 36	-		190	300	-
28	1x CC 12-630	-	CSA 12	-		290	390	-
29	1x CC 24-1250/2	-	CSA 12	-		300	410	-
30	-	1x CP1250-C	CSA 12	-		370	470	-
31	1x CC 24-630	-	CSA 24	-		290	390	-
32	1x CC 24-1250/2	-	CSA 24	-		300	410	-
33	-	1x CP1250-C	CSA 24	-		370	470	-
34	-	1x CP 630-M16	CSA 24	-		370	470	-
35	1x CC36-630 (1250)	-	CSA 24	-		300	400	-
36	1x CC 36-630	-	CSA 36	-		300	410	-
37	-	1x CP1250-C	CSA 36	-		370	480	-
38	-	1x CP 630-M16	CSA 36	-		370	480	-
39	1x CC36-630 (1250)	-	CSA 36	-		300	410	-
40	2x CC 12-630	-	CSA 12	-		390	490	-

Outer cone-type cable connection combinations

Tee plug and surge arrester

<1250 - 1 outer cone

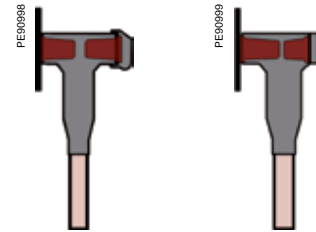
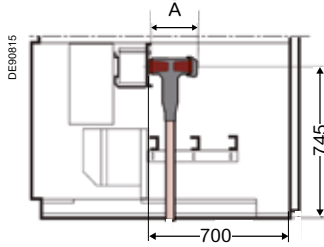

No.	Number of cables per panel and phase ⁽²⁾	Rated voltage kV	Supplier	Phase cross section mm ²	Insulation	Tee plug	Tee plug compact
41	3	≤12	nkt cables	185-500	Silicone	-	1x CB 24-1250/2
42	3	≤12	nkt cables	25-300	Silicone	-	3x CB 12-630
43	3	≤24	nkt cables	25-300	Silicone	-	1x CB 24-630
44	3	≤24	nkt cables	25-300	Silicone	-	3x CB 24-630
45	3	≤24	nkt cables	95-500	Silicone	-	1x CB 24-1250/2
46	3	≤24	nkt cables	400-630 / 800AL RE	Silicone	-	3x CB 36-630 (1250)
47	3	≤24	nkt cables	400-630 / 800AL RE	Silicone	-	1x CB 36-630 (1250)
48	3	≤36	nkt cables	25-300	Silicone	-	1x CB 36-630
49	3	≤36	nkt cables	25-300	Silicone	-	3x CB 36-630
50	3	≤36	nkt cables	400-630 / 800AL RE	Silicone	-	3x CB 36-630 (1250)
51	3	≤36	nkt cables	400-630 / 800AL RE	Silicone	-	1x CB 36-630 (1250)
52	1	≤12	TE Raychem	25-300	Silicone		RSTI 58XX
53	1	≤12	TE Raychem	400-800	Silicone		RSTI 395X
54	1	≤24	TE Raychem	25-300	Silicone		RSTI 58XX
55	1	≤24	TE Raychem	400-800	Silicone		RSTI 595X
56	1	≤36	TE Raychem	35-300	Silicone		RSTI 68XX
57	1	≤36	TE Raychem	400-800	Silicone		RSTI 695X
58	2	≤12	TE Raychem	25-300	Silicone		1 x RSTI 58XX
59	2	≤12	TE Raychem	400-800	Silicone		1 x RSTI 395X
60	2	≤24	TE Raychem	25-300	Silicone		1 x RSTI 58XX
61	2	≤24	TE Raychem	400-800	Silicone		1 x RSTI 595X
62	2	≤36	TE Raychem	35-300	Silicone		1 x RSTI 68XX
63	2	≤36	TE Raychem	400-800	Silicone		1 x RSTI 695X
64	3	≤12	TE Raychem	25-300	Silicone		1 x RSTI 58XX
65	3	≤12	TE Raychem	400-800	Silicone		1 x RSTI 395X
66	3	≤24	TE Raychem	25-300	Silicone		1 x RSTI 58XX
67	3	≤24	TE Raychem	400-800	Silicone		1 x RSTI 595X
68	3	≤36	TE Raychem	35-300	Silicone		1 x RSTI 68XX
69	3	≤36	TE Raychem	400-800	Silicone		1 x RSTI 695X
70	1	≤12	Südkabel	50-300	Silicone		1x SET 12
71	1	≤12	Südkabel	185-500	Silicone	1x SEHDT 13	
72	1	≤24	Südkabel	25-240	Silicone		1x SET 24
73	1	≤24	Südkabel	300	Silicone		1x SEHDT 23.1
74	1	≤24	Südkabel	120-300	Silicone		1x SAT 24
75	1	≤24	Südkabel	185-630	Silicone	1x SEHDT 23	
76	1	≤36	Südkabel	70-300	Silicone		1x SET 36
77	1	≤36	Südkabel	35-500	Silicone	1x SEHDT 33	
78	1	≤36	Südkabel	630-1000	Silicone		1x SAT 36
79	2	≤12	Südkabel	50-300	Silicone		2x SET 12
80	2	≤12	Südkabel	50-300	Silicone		1x SET 12

⁽¹⁾A detailed clarification of the surge arresters is required order-specifically with the manufacturer in question depending on the neutral-point connection and system configuration concerned

⁽²⁾Three-conductor cables available on request (connectors and accessories to be clarified with the connector supplier concerned)

Outer cone-type cable connection combinations

Tee plug and surge arrester

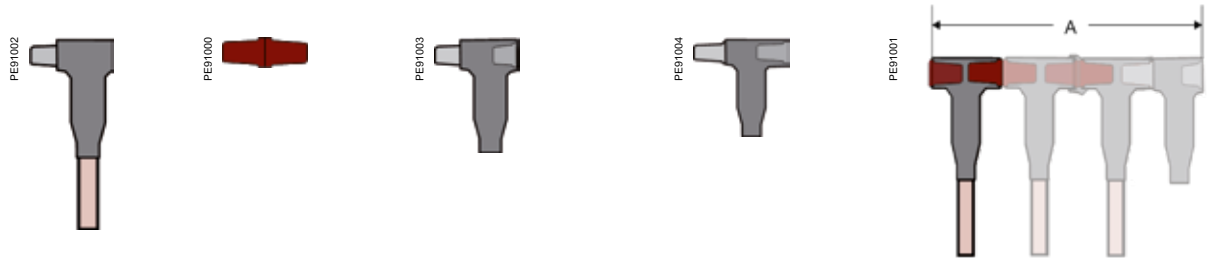

No.	Connector plug	Coupler	Surge arrester ⁽¹⁾		Length A max. 700 mm		
			Version 1	Version 2	without surge arrester	Version 1	Version 2
41	2 x CC 24-1250/2	-	CSA 12	-	300	410	510
42	-	2x CP1250-C	CSA 12	-	550	650	-
43	2x CC 24-630	-	CSA 24	-	390	490	-
44	-	2x CP1250-C	CSA 24	-	550	650	-
45	2 x CC 24-1250/2	-	CSA 24	-	300	410	510
46	-	2x CP 630-M16	CSA 24	-	550	650	-
47	2x CC36-630 (1250)	-	CSA 24	-	410	510	-
48	2x CC 36-630	-	CSA 36	-	410	520	-
49	-	2x CP1250-C	CSA 36	-	550	660	-
50	-	2x CP 630-M16	CSA 36	-	550	660	-
51	2x CC36-630 (1250)	-	CSA 36	-	410	520	-
52			RSTI-CC-58SAXX05	RSTI-CC-68SAXX10	180	285	292
53			RSTI-CC-58SAXX05	RSTI-CC-68SAXX10	190	295	302
54			RSTI-CC-58SAXX05	RSTI-CC-68SAXX10	180	285	292
55			RSTI-CC-58SAXX05	RSTI-CC-68SAXX10	190	295	302
56			RSTI-CC-68SAXX10		190	302	
57			RSTI-CC-68SAXX10		190	302	
58	1 x RSTI-CC-58XX		RSTI-CC-58SAXX05	RSTI-CC-68SAXX10	285	390	397
59	1 x RSTI-CC-395X		RSTI-CC-58SAXX05	RSTI-CC-68SAXX10	315	420	427
60	1 x RSTI-CC-58XX		RSTI-CC-58SAXX05	RSTI-CC-68SAXX10	285	390	397
61	1 x RSTI-CC-595X		RSTI-CC-58SAXX05	RSTI-CC-68SAXX10	315	420	427
62	1 x RSTI-CC-68XX		RSTI-CC-68SAXX10		295	407	
63	1 x RSTI-CC-695X		RSTI-CC-68SAXX10		315	427	
64	2 x RSTI-CC-58XX		RSTI-CC-58SAXX05	RSTI-CC-68SAXX10	390	495	502
65	2 x RSTI-CC-395X		RSTI-CC-58SAXX05	RSTI-CC-68SAXX10	440	545	552
66	2 x RSTI-CC-58XX		RSTI-CC-58SAXX05	RSTI-CC-68SAXX10	390	495	502
67	2 x RSTI-CC-595X		RSTI-CC-58SAXX05	RSTI-CC-68SAXX10	440	545	552
68	2 x RSTI-CC-68XX		RSTI-CC-68SAXX10		440	552	
69	2 x RSTI-CC-695X		RSTI-CC-68SAXX10		440	552	
70			1x MUT 23.1	-	189	290	-
71			-	1x MUT 33 + 1x KU 33	260	-	502
72			1x MUT 23.1	-	189	290	
73			1x MUT 23.1	-	189	290	
74			1x MUT 23.1	-	189	290	
75			-	1x MUT 33 + 1x KU 33	260		502
76			-	1x MUT 33 + 1x KU 33.1	192		434
77			-	1x MUT 33 + 1x KU 33	260		502
78			-	1x MUT 33 + 1x KU 33.1	201		457
79		1x KU 23.2/23	1x MUT 23.1	-	362	464	-
80	1x SEHDK 13.1	-	1x MUT 23.1	-	290	391	-

Outer cone-type cable connection combinations

Tee plug and surge arrester

<1250 - 1 outer cone

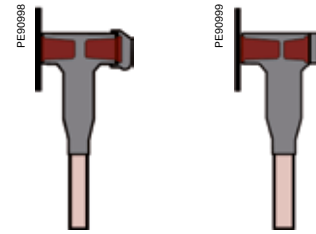
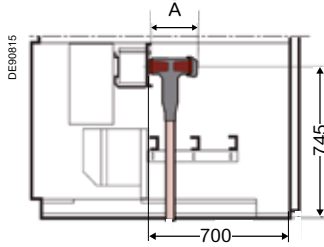

No.	Number of cables per panel and phase ⁽²⁾	Rated voltage kV	Supplier	Phase cross section mm ²	Insulation	Tee plug	Tee plug compact
81	2	≤12	Südkabel	185-500	Silicone	2x SEHDT 13	
82	2	≤24	Südkabel	25-240	Silicone		2x SET 24
83	2	≤24	Südkabel	50-240	Silicone		1x SET 24
84	2	≤24	Südkabel	120-300	Silicone		2x SAT 24
85	2	≤24	Südkabel	185-630	Silicone	2x SEHDT 23	
86	2	≤36	Südkabel	70-300	Silicone		2x SET 36
87	2	≤36	Südkabel	35-500	Silicone	2x SEHDT 33	
88	2	≤36	Südkabel	630-1000	Silicone		2x SAT 36
89	3	≤12	Südkabel	50-300	Silicone		3x SET 12
90	3	≤12	Südkabel	50-300	Silicone		2x SET 12
91	3	≤12	Südkabel	50-300	Silicone		1x SET 12
92	3	≤24	Südkabel	25-240	Silicone		3x SET 24
93	3	≤24	Südkabel	25-240	Silicone		2x SET 24
94	3	≤24	Südkabel	25-240	Silicone		1x SET 24
95	3	≤36	Südkabel	70-300	Silicone		3x SET 36
96	3	≤36	Südkabel	70-300	Silicone		2x SET 36
97	3	≤36	Südkabel	70-300	Silicone		1x SET 36

⁽¹⁾A detailed clarification of the surge arresters is required order-specifically with the manufacturer in question depending on the neutral-point connection and system configuration concerned

⁽²⁾Three-conductor cables available on request (connectors and accessories to be clarified with the connector supplier concerned)

Outer cone-type cable connection combinations

Tee plug and surge arrester

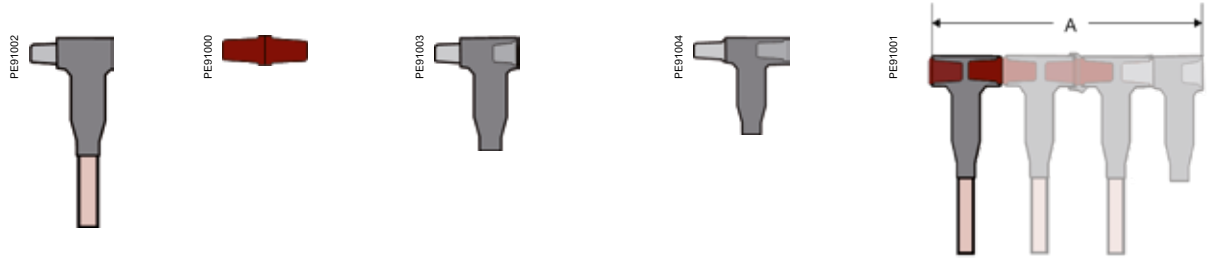

No.	Connector plug	Coupler	Surge arrester ⁽¹⁾		Length A max. 700 mm		
			Version 1	Version 2	without surge arrester	Version 1	Version 2
81		1x KU 33	-	-	522	-	-
82		1x KU 23.2/23	1x MUT 23.1	-	362	464	-
83	1x SEHDK 23.1	-	1x MUT 23.1	-	290	391	-
84		1x KU 33.1	1x MUT 23.1	-	362	464	-
85		1x KU 33	-	-	522	-	-
86		1x KU 33.1	-	1x MUT 33 + 1x KU 33.1	386	-	623
87		1x KU 33	-	-	522	-	-
88		1x KU 33.1	-	1x MUT 33 + 1x KU 33.1	404	-	646
89		2x KU 23.2/23	1x MUT 23.1	-	536	637	-
90	1x SEHDK 13.1	1x KU 23.2/23	1x MUT 23.1	-	463	564	-
91	2x SEHDK 13.1	-	1x MUT 23.1	-	390	491	-
92		2x KU 23.2/23	1x MUT 23.1	-	536	637	-
93	1x SEHDK 23.1	1x KU 23.2/23	1x MUT 23.1	-	463	564	-
94	2x SEHDK 23.1	-	1x MUT 23.1	-	390	491	-
95		2x KU 33.1	-	-	580	-	-
96	1x SEHDK 36	1x KU 33.1	-	-	485	-	-
97	2x SEHDK 36			1x MUT 33 + 1x KU 33.1	421		662

Outer cone-type cable connection combinations

Tee plug and surge arrester

>1250 to <2500 A - 2 outer cones

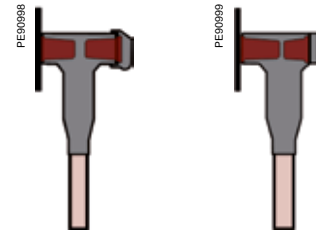
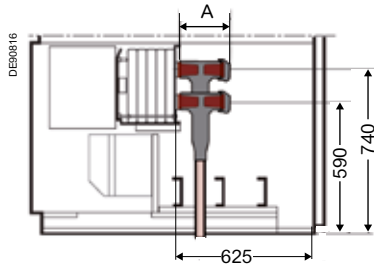

No.	Number of cables per panel and phase ⁽²⁾	Rated voltage kV	Supplier	Phase cross section mm ²	Insulation	Tee plug	Tee plug compact
1	2	≤12	Euromold/Nexans	25-300	EPDM		2x 430TB
2	2	≤12	Euromold/Nexans	400-630	EPDM		2x 484TB
3	2	≤24	Euromold/Nexans	25-300	EPDM		2x K430TB
4	2	≤24	Euromold/Nexans	400-630	EPDM		2x K484TB
5	2	≤36	Euromold/Nexans	25-240	EPDM		2x M430TB
6	2	≤36	Euromold/Nexans	300-630	EPDM		2x M484TB
7	4	≤12	Euromold/Nexans	25-300	EPDM		2x 430TB
8	4	≤12	Euromold/Nexans	25-300	EPDM		4x 430TB
9	4	≤12	Euromold/Nexans	400-630	EPDM		2x 484TB
10	4	≤24	Euromold/Nexans	25-300	EPDM		2x K430TB
11	4	≤24	Euromold/Nexans	25-300	EPDM		4x K 430TB
12	4	≤24	Euromold/Nexans	400-630	EPDM		2x K484TB
13	4	≤36	Euromold/Nexans	50-240	EPDM		2x M430TB
14	4	≤36	Euromold/Nexans	300-630	EPDM		2x M484TB
15	6	≤12	Euromold/Nexans	25-300	EPDM		2x 430TB
16	6	≤24	Euromold/Nexans	25-300	EPDM		2x K430TB
17	6	≤36	Euromold/Nexans	25-240	EPDM		2x M430TB
18	6	≤12	Euromold/Nexans	400-630	EPDM		2x 484TB
19	6	≤24	Euromold/Nexans	400-630	EPDM		2x K484TB
20	6	≤36	Euromold/Nexans	300-630	EPDM		2x M484TB
21	2	≤12	nkt cables	25-300	Silicone	-	2x CB 12-630
22	2	≤12	nkt cables	185-500	Silicone	-	2x CB 24- 1250/2
23	2	≤24	nkt cables	25-300	Silicone	-	2x CB 24-630
24	2	≤24	nkt cables	95-500	Silicone	-	2x CB 24- 1250/2
25	2	≤24	nkt cables	400-630 / 800AL RE	Silicone	-	2x CB 36-630 (1250)
26	2	≤36	nkt cables	25-300	Silicone	-	2 x CB 36-630
27	2	≤36	nkt cables	400-630 / 800AL RE	Silicone	-	2x CB 36-630 (1250)
28	4	≤12	nkt cables	25-300	Silicone	-	4x CB 12-630
29	4	≤12	nkt cables	25-300	Silicone	-	2x CB 12-630
30	4	≤12	nkt cables	185-500	Silicone	-	2x CB 24- 1250/2
31	4	≤24	nkt cables	25-300	Silicone	-	4x CB 24-630
32	4	≤24	nkt cables	25-300	Silicone	-	2x CB 24-630
33	4	≤24	nkt cables	95-500	Silicone	-	2x CB 24- 1250/2
34	4	≤24	nkt cables	400-630 / 800AL RE	Silicone	-	2x CB 36-630 (1250)
35	4	≤24	nkt cables	400-630 / 800AL RE	Silicone	-	4x CB 36-630 (1250)
36	4	≤36	nkt cables	25-300	Silicone	-	2x CB 36-630
37	4	≤36	nkt cables	25-300	Silicone	-	4x CB 36-630
38	4	≤36	nkt cables	400-630 / 800AL RE	Silicone	-	2x CB 36-630 (1250)
39	4	≤36	nkt cables	400-630 / 800AL RE	Silicone	-	4x CB 36-630 (1250)
40	6	≤12	nkt cables	25-300	Silicone	-	6x CB 12-630

⁽¹⁾A detailed clarification of the surge arresters is required order-specifically with the manufacturer in question depending on the neutral-point connection and system configuration concerned

⁽²⁾Three-conductor cables available on request (connectors and accessories to be clarified with the connector supplier concerned)

Outer cone-type cable connection combinations

Tee plug and surge arrester

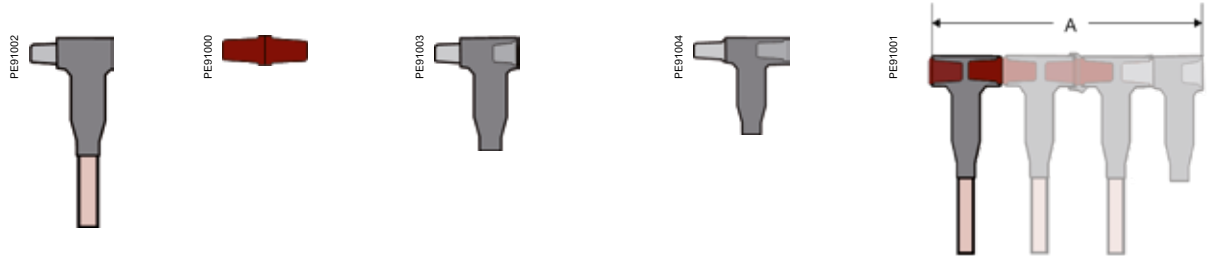

No.	Connector plug	Coupler	Surge arrester ⁽¹⁾		Length A max. 625 mm		
			Version 1	Version 2	without surge arrester	Version 1	Version 2
1				300SA	185		290
2				800SA	185		290
3				300SA	185		290
4				800SA	185		290
5				300SA	185		290
6				800SA	185		290
7	2x 300PB			300SA	290		395
8		2x 430CP		300SA	375		480
9	2x 804PB			800SA	290		400
10	2x K300PB			300SA	290		395
11		2x K430CP		300SA	375		480
12	2x K804PB			800SA	290		400
13	2x M300PB			300SA	290		395
14	2x M804PB			800SA	290		400
15	4x 300PB			300PB	395		500
16	4x K300PB			300PB	395		500
17	4x M300PB			300SA	395		500
18	4x 804TB			800SA	400		510
19	4x K804TB			800SA	400		510
20	4x M804TB			800SA	400		510
21	-	-	CSA 12	-	190	290	-
22	-	-	CSA 12	-	190	300	-
23	-	-	CSA 24	-	190	290	-
24	-	-	CSA 24	-	190	300	-
25	-	-	CSA 36	-	190	300	-
26	-	-	CSA 36	-	190	300	-
27	-	-	CSA 36	-	290	390	-
28	-	2x CP 1250C	CSA 12	-	370	470	-
29	2x CC 24-630	-	CSA 12	-	290	390	-
30	2x CC 24-1250/2	-	CSA 12	-	190	300	400
31	-	2x CP 1250-C	CSA 24	-	370	470	-
32	2x CC 24-630	-	CSA 24	-			-
33	2x CC 24-1250/2	-	CSA 24	-	190	300	400
34	2x CC36-630 (1250)	-	CSA 24	-	300	400	-
35		2x CP 630-M16	CSA 36	-	300	410	-
36	2x CC 36-630	-	CSA 36	-	370	480	-
37	-	2x CP 1250-C	CSA 36	-	370	480	-
38	2x CC36-630 (1250)	-	CSA 36	-	300	410	-
39		2x CP 630-M16	CSA 12	-	390	490	-
40	-	4x CP 1250-C	CSA 12	-	550		-

Outer cone-type cable connection combinations

Tee plug and surge arrester

>1250 to <2500 A - 2 outer cones

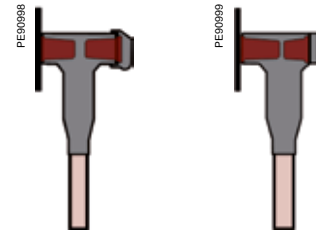
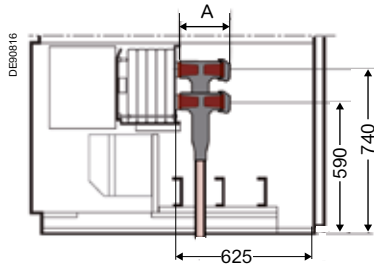

No.	Number of cables per panel and phase ⁽²⁾	Rated voltage kV	Supplier	Phase cross section mm ²	Insulation	Tee plug	Tee plug compact
41	6	<=12	nkt cables	25-300	Silicone	-	2x CB 12-630
42	6	<=12	nkt cables	185-500	Silicone	-	2x CB 24- 1250/2
43	6	<=24	nkt cables	25-300	Silicone	-	6x CB 24-630
44	6	<=24	nkt cables	25-300	Silicone	-	6x CB 24-630
45	6	<=24	nkt cables	95-500	Silicone	-	2x CB 24- 1250/2
46	6	<=24	nkt cables	400-630 / 800AL RE	Silicone	-	2x CB 36-630 (1250)
47	6	<=24	nkt cables	400-630 / 800AL RE	Silicone	-	6x CB 36-630 (1250)
48	6	<=36	nkt cables	25-300	Silicone	-	2x CB 36-630
49	6	<=36	nkt cables	25-300	Silicone	-	6x CB 36-630
50	6	<=36	nkt cables	400-630 / 800AL RE	Silicone	-	2x CB 36-630 (1250)
51	6	<=36	nkt cables	400-630 / 800AL RE	Silicone	-	6x CB 36-630 (1250)
52	2	<= 12	TE Raychem	25-300	Silicone		2x RSTI 58XX
53	2	<= 12	TE Raychem	400-800	Silicone		2x RSTI 395X
54	2	<= 24	TE Raychem	25-300	Silicone		2x RSTI 58XX
55	2	<= 24	TE Raychem	400-800	Silicone		2x RSTI 595X
56	2	<= 36	TE Raychem	35-300	Silicone		2x RSTI 68XX
57	2	<= 36	TE Raychem	400-800	Silicone		2x RSTI 695X
58	4	<= 12	TE Raychem	25-300	Silicone		2x RSTI 58XX
59	4	<= 12	TE Raychem	400-800	Silicone		2x RSTI 395X
60	4	<= 24	TE Raychem	25-300	Silicone		2x RSTI 58XX
61	4	<= 24	TE Raychem	400-800	Silicone		2x RSTI 595X
62	4	<= 36	TE Raychem	35-300	Silicone		2x RSTI 68XX
63	4	<= 36	TE Raychem	400-800	Silicone		2x RSTI 695X
64	6	<= 12	TE Raychem	25-300	Silicone		2x RSTI 58XX
65	6	<= 12	TE Raychem	400-800	Silicone		2x RSTI 395X
66	6	<= 24	TE Raychem	25-300	Silicone		2x RSTI 58XX
67	6	<= 24	TE Raychem	400-800	Silicone		2x RSTI 595X
68	6	<= 36	TE Raychem	35-300	Silicone		2x RSTI 68XX
69	6	<= 36	TE Raychem	400-800	Silicone		2x RSTI 695X
70	2	<=12	Südkabel	50-300	Silicone		2x SET 12
71	2	<=12	Südkabel	185-500	Silicone	2x SEHDT 13	
72	2	<=24	Südkabel	25-240	Silicone		2x SET 24
73	2	<=24	Südkabel	300	Silicone		2x SEHDT 23.1
74	2	<=24	Südkabel	120-300	Silicone		2x SAT 24
75	2	<=24	Südkabel	185-630	Silicone	2x SEHDT 23	
76	2	<=36	Südkabel	70-300	Silicone		2x SET 36
77	2	<=36	Südkabel	35-500	Silicone	2x SEHDT 33	
78	2	<=36	Südkabel	630-1000	Silicone		2x SAT 36
79	4	<=12	Südkabel	50-300	Silicone		2x SET 12
80	4	<=12	Südkabel	50-300	Silicone		2x SET 12

⁽¹⁾A detailed clarification of the surge arresters is required order-specifically with the manufacturer in question depending on the neutral-point connection and system configuration concerned

⁽²⁾Three-conductor cables available on request (connectors and accessories to be clarified with the connector supplier concerned)

Outer cone-type cable connection combinations

Tee plug and surge arrester

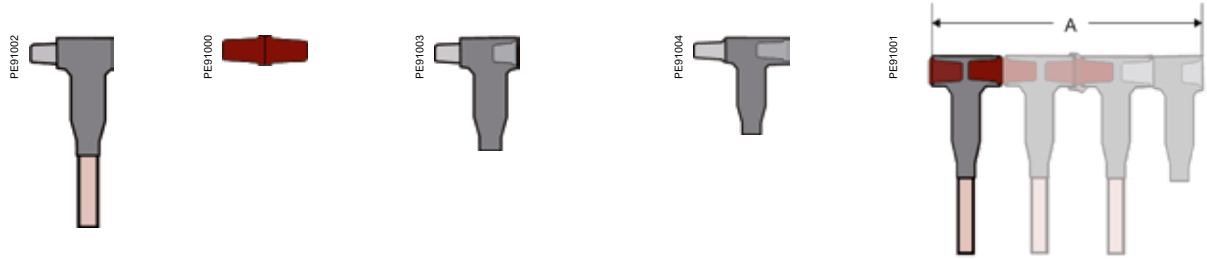

No.	Connector plug	Coupler	Surge arrester ⁽¹⁾		Length A max. 625 mm		
			Version 1	Version 2	without surge arrester	Version 1	Version 2
41	4x CC 12-630	-	CSA 24	-	390	490	-
42	4x CC 24-1250/2	-	CSA 12	-	190	300	-
43	-	4x CP 1250-C	CSA 24	-	550	-	-
44	4x CC 24-630	-	CSA 24	-	550	-	-
45	4x CC 24-1250/2	-	CSA 24	-	190	300	-
46	4x CC36-630 (1250)	-	CSA 24	-	410	510	-
47	-	4x CP 630-M16	CSA 36	-	410	520	-
48	4 x CC 36-630	-	CSA 36	-	550	-	-
49	-	4x CP 1250-C	CSA 36	-	550	-	-
40	4x CC36-630 (1250)	-	CSA 36	-	410	520	-
51	-	4x CP 630-M16	CSA 36	-	550	-	-
52			RSTI-CC-58SAXX05	RSTI-CC-68SAXX10	180	285	292
53			RSTI-CC-58SAXX05	RSTI-CC-68SAXX10	190	295	302
54			RSTI-CC-58SAXX05	RSTI-CC-68SAXX10	180	285	292
55			RSTI-CC-58SAXX05	RSTI-CC-68SAXX10	190	295	302
56			RSTI-CC-68SAXX10		190	302	
57			RSTI-CC-68SAXX10		190	302	
58	2x RSTI-CC-58XX		RSTI-CC-58SAXX05	RSTI-CC-68SAXX10	285	390	397
59	2x RSTI-CC-395X		RSTI-CC-58SAXX05	RSTI-CC-68SAXX10	315	420	427
50	2x RSTI-CC-58XX		RSTI-CC-58SAXX05	RSTI-CC-68SAXX10	285	390	397
61	2x RSTI-CC-595X		RSTI-CC-58SAXX05	RSTI-CC-68SAXX10	315	420	427
62	2x RSTI-CC-68XX		RSTI-CC-68SAXX10		295	407	
63	2x RSTI-CC-695X		RSTI-CC-68SAXX10		315	427	
64	4x RSTI-CC-58XX		RSTI-CC-58SAXX05	RSTI-CC-68SAXX10	390	495	502
65	4x RSTI-CC-395X		RSTI-CC-58SAXX05	RSTI-CC-68SAXX10	440	545	552
66	4x RSTI-CC-58XX		RSTI-CC-58SAXX05	RSTI-CC-68SAXX10	390	495	502
67	4x RSTI-CC-595X		RSTI-CC-58SAXX05	RSTI-CC-68SAXX10	440	545	552
68	4x RSTI-CC-68XX		RSTI-CC-68SAXX10		440	552	
69	4x RSTI-CC-695X		RSTI-CC-68SAXX		440	552	
70			2x MUT 23.1	-	189	290	-
71			-	2x MUT 33 + 2x KU 33	260	-	502
72			2x MUT 23.1	-	189	290	-
73			2x MUT 23.1	-	189	290	--
74			2x MUT 23.1	-	189	290	-
75			-	2x MUT 33 + 2x KU 33	260	-	502
76			-	2x MUT 33 + 2x KU 33.1	192	-	434
77			-	2x MUT 33 + 2x KU 33	260	-	502
78			-	2x MUT 33 + 2x KU 33.1	201	-	457
79		2x KU 23.2/23	2x MUT 23.1	-	362	464	-
80	2x SEHDK 13.1	-	2x MUT 23.1	-	290	391	-

Outer cone-type cable connection combinations

Tee plug and surge arrester

>1250 to <2500 A - 2 outer cones

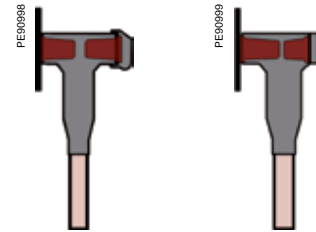
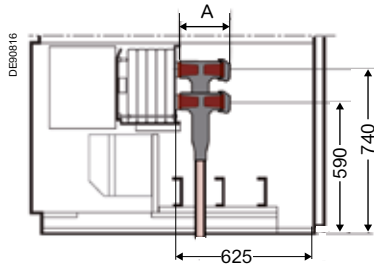

No.	Number of cables per panel and phase ⁽²⁾	Rated voltage kV	Supplier	Phase cross section mm ²	Insulation	Tee plug	Tee plug compact
81	4	≤12	Südkabel	185-500	Silicone	4x SEHDT 13	
82	4	≤24	Südkabel	25-240	Silicone		4x SET 24
83	4	≤24	Südkabel	50-240	Silicone		2x SET 24
84	4	≤24	Südkabel	120-300	Silicone		4x SAT 24
85	4	≤24	Südkabel	185-630	Silicone	4x SEHDT 23	
86	4	≤36	Südkabel	70-300	Silicone		4x SET 36
87	4	≤36	Südkabel	35-500	Silicone	4x SEHDT 33	
88	4	≤36	Südkabel	630-1000	Silicone		4x SAT 36
89	6	≤12	Südkabel	50-300	Silicone		6x SET 12
90	6	≤12	Südkabel	50-300	Silicone		4x SET 12
91	6	≤12	Südkabel	50-300	Silicone		2x SET 12
92	6	≤24	Südkabel	25-240	Silicone		6x SET 24
93	6	≤24	Südkabel	25-240	Silicone		4x SET 24
94	6	≤24	Südkabel	25-240	Silicone		2x SET 24
95	6	≤36	Südkabel	70-300	Silicone		6x SET 36
96	6	≤36	Südkabel	70-300	Silicone		4x SET 36
97	6	≤36	Südkabel	70-300	Silicone		2x SET 36

⁽¹⁾A detailed clarification of the surge arresters is required order-specifically with the manufacturer in question depending on the neutral-point connection and system configuration concerned

⁽²⁾Three-conductor cables available on request (connectors and accessories to be clarified with the connector supplier concerned)

Outer cone-type cable connection combinations

Tee plug and surge arrester

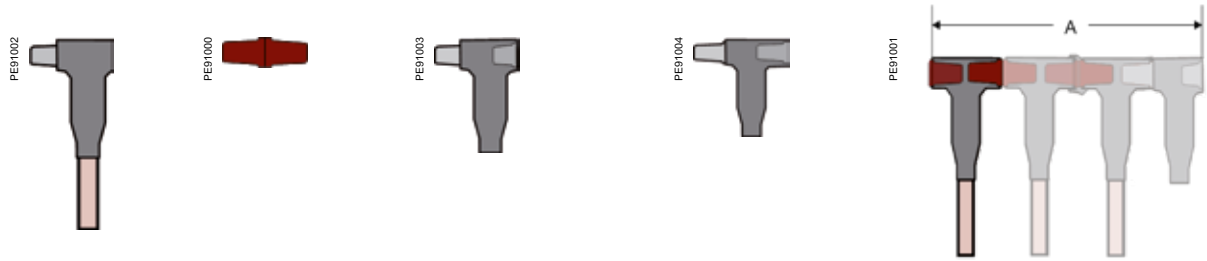

No.	Connector plug	Coupler	Surge arrester ⁽¹⁾		Length A max. 625 mm		
			Version 1	Version 2	without surge arrester	Version 1	Version 2
81		2x KU 33	-	-	522	-	-
82		2x KU 23.2/23	2x MUT 23.1	-	362	464	-
83	2x SEHDK 23.1	-	2x MUT 23.1	-	290	391	-
84		2x KU 33.1	2x MUT 23.1	-	362	464	-
85		2x KU 33	-	-	522	-	-
86		2x KU 33.1	-	2x MUT 33 + 2x KU 33.1	386	-	623
87		2x KU 33	-	-	522	-	-
88		2x KU 33.1	-	2x MUT 33 + 2x KU 33.1	404	-	646
89		4x KU 23.2/23	2x MUT 23.1	-	536	-	-
90	2x SEHDK 13.1	2x KU 23.2/23	2x MUT 23.1	-	463	564	-
91	4x SEHDK 13.1	-	2x MUT 23.1	-	390	491	-
92		4x KU 23.2/23	2x MUT 23.1	-	536	-	-
93	2x SEHDK 23.1	2x KU 23.2/23	2x MUT 23.1	-	463	564	-
94	4x SEHDK 23.1	-	2x MUT 23.1	-	390	491	-
95		4x KU 33.1	-	-	580	-	-
96	2x SEHDK 36	2x KU 33.1	-	-	485	-	-
97	4x SEHDK 36	-	-	2x MUT 33 + 2x KU 33.1	421	-	-

Accessory boards

Fixed and mobile accessory boards

A stationary accessory board is available for central storage of the most important accessories. A mobile version is also available.

Both versions can accommodate an operating crank handle kit when provided for maximum equipment.

Basic equipment fitted for circuit-breaker switchgear cubicles:

The mobile accessory board can be suspended centrally on a wall of the switchgear room via 2 securing bolts, and can be removed if required.

A handle ensures safe transport.

A mobile accessory board can accommodate the following elements:

- Crank of 3-position switch
- Emergency crank handle for the stored energy spring-mechanism of the circuit breaker
- Double-bit key
- Switchgear documentation (DIN A4)

PM103.126



PM102839



Mobile accessory board, suspended in the profile strip of the cable compartment cover

Schneider Electric Industries SAS

35 rue Joseph Monier
92500 Rueil-Malmaison, France
Tel : +33 (0)1 41 29 70 00

www.schneider-electric.com

SAS capital social 928 298 512 €
954 503 439 RCS Nanterre

02/2018
NRJCAT18789EN

©2018 Schneider Electric SE. All rights reserved. All Schneider Electric trademarks and service marks are the property of Schneider Electric SE, its subsidiaries and affiliated companies.